

6/24/2020

GROSS LOAD CAPACITY WHEN USED AS A WEIGHT CARRYING HITCH: 5,000 LBS. TRAILER WEIGHT & 500 LBS. TONGUE WEIGHT.
 GROSS LOAD CAPACITY WHEN USED AS A WEIGHT DISTRIBUTION HITCH: 6,000 LBS. TRAILER WEIGHT & 600 LBS. TONGUE WEIGHT

*****DO NOT EXCEED VEHICLE MANUFACTURER'S RECOMMENDED TOWING CAPACITY.*****

Parts List			
ITEM	QTY	PART NUMBER	DESCRIPTION
1	4	10-10334	HHCS, 1/2-13 UNC, 1-1/2, GRD8, YZ
2	4	30-00149	WASHER, S-CON, 1/2, YZ
3	1	CM-NP4W	NUT PLATE WELDMENT
4	1	CM-NP3W	NUT PLATE WELDMENT

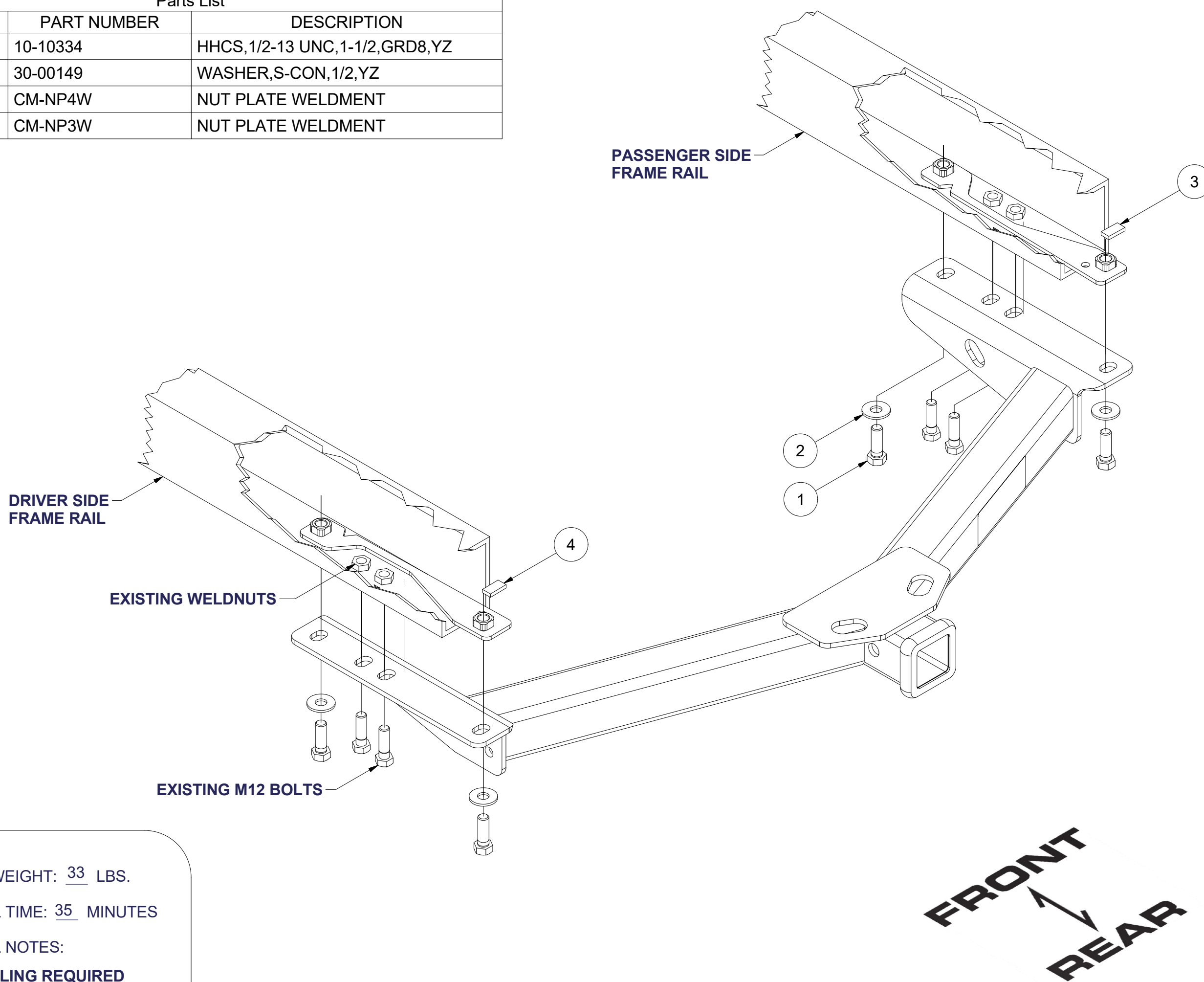

HITCH WEIGHT: 33 LBS.
 INSTALL TIME: 35 MINUTES
 INSTALL NOTES:
NO DRILLING REQUIRED

INSTALLATION STEPS

- 1) Remove tow hooks from vehicle frame.
- 2) Position weldnut plates inside frame as shown.
- 3) Raise hitch into position and align the side brackets with the existing tow hook holes at the end of the frame rails. Reinstall the existing M12 bolts and tow hooks removed in step 1.
- 4) Insert 1/2" bolt and conical tooth washer through rearmost existing hole in hitch. This will thread into weldnut plate as shown. Hand tighten only at this time.
- 5) Insert 1/2" bolt and conical tooth washer through foremost existing hole in hitch. This will thread into weldnut plate as shown. Hand tighten only at this time.
- 6) Torque M12 fasteners to 86 lb.-ft. and 1/2" fasteners to 110 lb.-ft.

PERIODICALLY CHECK THIS RECEIVER HITCH TO ENSURE THAT ALL FASTENERS ARE TIGHT AND THAT ALL STRUCTURAL COMPONENTS ARE SOUND.

Curt Manufacturing Inc., warrants this product to be free of defects in material and/or workmanship at the time of retail purchase by the original purchaser. If the product is found to be defective, Curt Manufacturing Inc., may repair or replace the product, at their option, when the product is returned, prepaid, with proof of purchase. Alteration to, misuse of, or improper installation of this product voids the warranty. Curt Manufacturing Inc.'s liability is limited to repair or replacement of products found to be defective, and specifically excludes liability for incidental or consequential loss or damage.