

INSTALLATION INSTRUCTIONS AND PARTS LIST

VEHICLE APPLICATION:

MODEL: 251123 (12" X 23") & 251120 (12" X 20") FRONT OR REAR MUDGUARDS
2008 AND NEWER FORD SUPER DUTY SINGLE WHEEL TRUCKS

1. READ INSTRUCTIONS COMPLETELY AND CHECK TO MAKE SURE THAT ALL REQUIRED PARTS (LISTED ON SERVICE PARTS LIST) ARE ON HAND BEFORE STARTING THE INSTALLATION.
2. PREPARE THE SPLASH GUARDS AND VEHICLE FOR MUDGUARD INSTALLATION AS FOLLOWS:
 - 2.1. ON REAR APPLICATION, ATTACH THE MOUNTING BRACKETS (ITEM 9) TO THE MUDGUARDS AS SHOWN. USE 10-24 X 1.0" TRUSS HEAD SCREWS (ITEM 4), 1/4" FENDER WASHER (ITEM 12), #10 FLAT WASHER (ITEM #5) AND 10-24 NYLOCK NUTS (ITEM 3). (USE THE BOTTOM HOLE IN THE BRACKET).

MOUNTING 251123 / 251120 MUDGUARDS ON THE FRONT: (SEE SHEET #3)

3. INSTALL THE MUDGUARDS AS FOLLOWS:
 - 3.1. REMOVE THE FACTORY WHEEL WELL LINER RETAINER SCREWS. (THESE SCREWS WILL NOT BE REUSED). YOU MAY NEED TO ADD A SPEED NUT (ITEM #7) TO THE UPPER HOLE.
 - 3.2. POSITION THE MUDGUARD AGAINST THE WHEEL WELL FLANGE AS SHOWN FOR YOUR APPLICATION. INSTALL A HEX HEAD SEMS SCREW (ITEM #6), AND 1/4" FENDER WASHERS (ITEM #12) IN THE PROPER HOLES. IF NEEDED INSTALL THE NYLON SPACER (ITEM #8) BETWEEN MUDGUARD AND FLANGE, THIS WILL ONLY BE USED FOR THE LOWER HOLE ON 2011 TRUCKS WITH FLARES. (LEAVE THESE FASTENERS FINGER TIGHT). **NOTE: THAT THE HOLE LOCATIONS FOR THE 2008-10 ARE DIFFERENT FROM THE LOCATIONS FOR THE 2011.**
 - 3.3. ON THE PASSENGER SIDE, USING THE INBOARD UPPER HOLE AS A PILOT, DRILL A 1/4" DIA. HOLE THRU THE WHEEL WELL LINER. INSTALL A 10-24 X 1.0" TRUSS HEAD SCREWS (ITEM 4), 1/4" FENDER WASHER (ITEM 12), #10 FLAT WASHER (ITEM #5), 10-24 NYLOCK NUTS (ITEM 3) AND NYLON SPACER (ITEM #8) AS SHOWN.
 - 3.4. IF NEEDED ON THE **DRIVERS** SIDE INSTALL THE SLOTTED ZEE CLIP (ITEM# 11) TO THE BACKSIDE OF MUD GUARD USING A 10-24 X 1.0" TRUSS HEAD SCREWS (ITEM 4), 1/4" FENDER WASHER (ITEM 12), #10 FLAT WASHER (ITEM #5) AND 10-24 NYLOCK NUTS (ITEM 3). THEN USING THE UPPER HOLE IN THE ZEE CLIP AS A PILOT, DRILL A 1/4" DIA. HOLE THRU THE WHEEL WELL LINER. A 10-24 X 1.0" TRUSS HEAD SCREWS (ITEM 4), #10 FLAT WASHER (ITEM #5), 10-24 NYLOCK NUTS (ITEM 3). **FIG 3**
 - 3.5. MOVE THE MUDGUARDS IN OR OUT AS DESIRED, INSURE THE MUDGUARD IS LEVEL AND TIGHTEN ALL FASTENERS.**FIG 1& 2**

MOUNTING 251123 / 251120 MUDGUARDS ON THE REAR WITH FENDER FLARES: (SEE SHEET #4)

4. INSTALL THE MUDGUARDS AS FOLLOWS:
 - 4.1. REMOVE THE FACTORY WHEEL WELL LINER RETAINER SCREWS. (THESE SCREWS WILL NOT BE REUSED).
 - 4.2. POSITION THE MUDGUARD AGAINST THE WHEEL WELL FLANGE AS SHOWN FOR YOUR APPLICATION. INSTALL (2) 10-24 X 1.00" TRUSS HEAD SCREWS (ITEM #4), 1/4" FENDER WASHERS (ITEM #12) #10 FLAT WASHERS (ITEM #5) AND 10-24 NYLOCK NUTS (ITEM #3) AS SHOWN (LEAVE THESE FASTENERS FINGER TIGHT). **NOTE: THAT THE HOLE LOCATIONS FOR THE 2008-10 ARE DIFFERENT FROM THE LOCATIONS FOR THE 2011.**



(A LUVERNE Company)

1200 E. Birch St.

Brandon, SD 57005

REV C 23DEC11
REV B 28SEP10
REV A 28JUL10
550235 SHEET 1 16APR10

- 4.3. MOVE THE MUDGUARDS IN OR OUT AS DESIRED, LEVEL THE MUDGUARDS, TIGHTEN THE TOP FASTENERS AND CLAMP THE TOP OF THE MOUNTING BRACKET TO THE INNER WHEEL WELL PINCH WELD.
- 4.4. USING THE HOLE IN THE BRACKET (ITEM #9) AS A PILOT, DRILL A 3/16" DIA HOLE THRU THE BOX PINCH WELD AND FASTEN WITH A 1/4" X 3/4" THREAD FORMING SCREW (ITEM #10).
- 4.5. TIGHTEN ALL FASTENERS.

MOUNTING 251123/251120 MUDGUARDS ON THE REAR WITHOUT FENDER FLARES:

5. INSTALL THE MUD GUARD AS FOLLOWED
 - 5.1. USING THE PROPER UPPER HOLE IN THE SPLASH GUARDS INSTALL 10-24 X 1.00" TRUSS HEAD SCREWS (ITEM #4), 1/4" FENDER WASHERS (ITEM #12) #10 FLAT WASHERS (ITEM #5) AND 10-24 NYLOCK NUTS (ITEM #3) AS SHOWN (FINGER TIGHTEN).
 - 5.2. MOVE THE MUDGUARDS IN OR OUT AS DESIRED, LEVEL THE MUDGUARDS, TIGHTEN THE TOP FASTENER. IN THE PROPER LOWER HOLE DRILL A 1/4" HOLE IN WHEEL WELL FLANGE.
 - 5.3. INSTALL 10-24 X 1.00" TRUSS HEAD SCREWS (ITEM #4), 1/4" FENDER WASHERS (ITEM #12) #10 FLAT WASHERS (ITEM #5) AND 10-24 NYLOCK NUTS (ITEM #3) AS SHOWN. THEN PROCEED TO STEPS 4.4 AND 4.5.

PARTS LIST

| ITEM | PART NO. | QTY | DESCRIPTION |
|------|----------|-----|--|
| 1 | 550233 | 1 | MUDGUARD-,12X23,FORD SD,RH |
| 2 | 550234 | 1 | MUDGUARD-,12X23,FORD SD,LH |
| 1 | 550237 | 1 | MUDGUARD-,12X20,FORD SD,RH |
| 2 | 550238 | 1 | MUDGUARD-,12X20,FORD SD,LH |
| | | | |
| 3 | 107864 | 6 | NUT-HEX,NYLOCK,SST,#10-24 |
| 4 | 105516 | 6 | SCR-TRUSS HD,XREC,SST 10-24 X 1.00 |
| 5 | 105511 | 6 | WASHER-FLAT,SST,.203 X .625 X .062 |
| 6 | 105514 | 4 | SCREW-SEMS,HEX HD,M4.2-1.41 X 30MM |
| 7 | 105518 | 2 | NUT-SPEED,U-TYPE,SGL THD,#8,BLK PHOS PLT |
| 8 | 107182 | 4 | WSHR-SPCR,NYLON,BLACK,.38 X .25 |
| 9 | 544060 | 2 | BRACKET-MOUNTING |
| 10 | 102694 | 2 | SCREW-TF,AB,SST,1/4 X3/4 |
| 11 | 605330 | 1 | SLOTTED ZEE CLIP,SST,158-ZS |
| 12 | 108521 | 6 | WASHER-FENDER, 1/4 X 1", SST, BLK ZP |



(A LIVERNE Company)

1200 E. Birch St.

Brandon, SD 57005

REV C 23DEC11
REV B 28SEP10
REV A 28JUL10
550235 SHEET 2 16APR10

08-10 SUPER DUTY

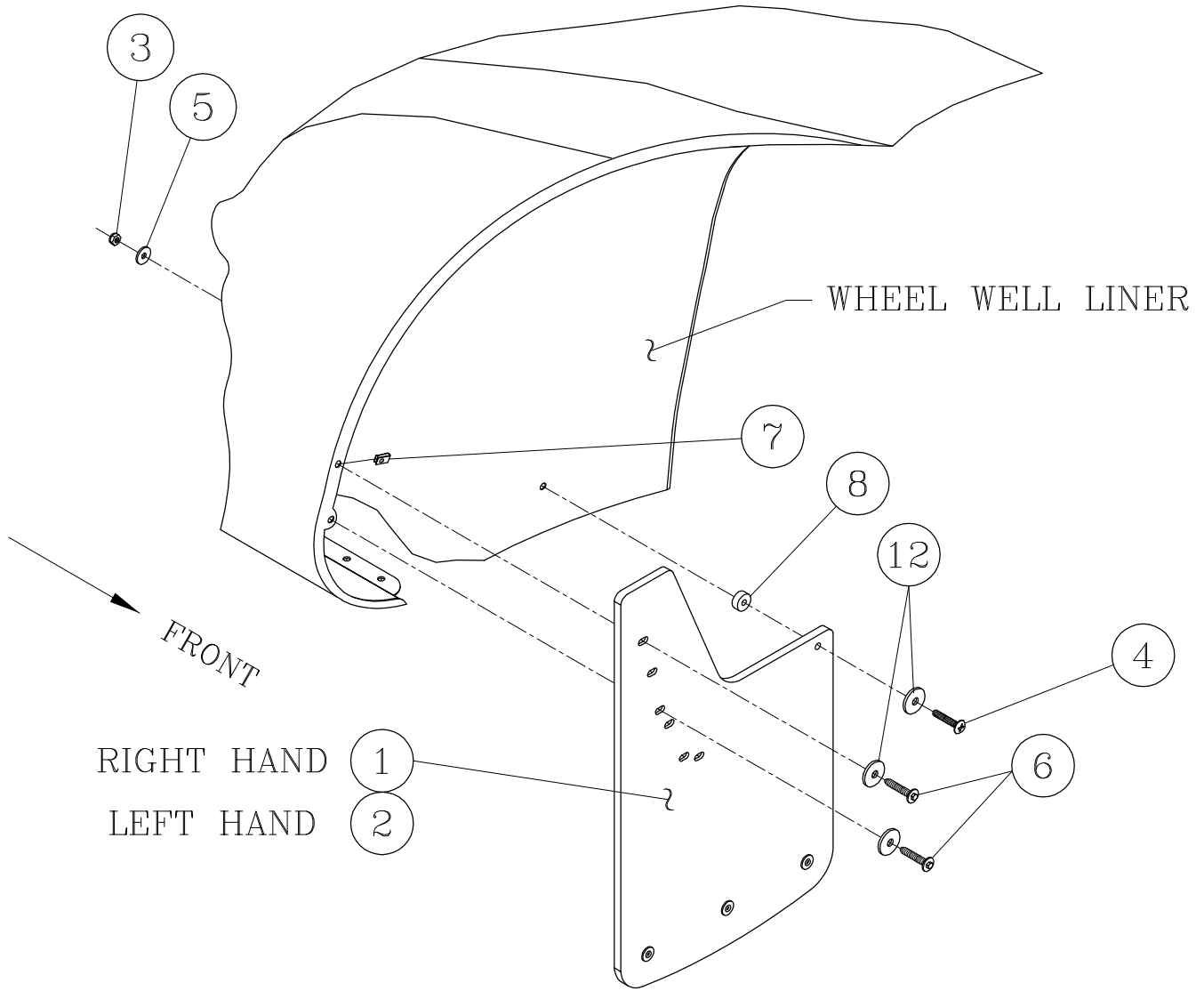

FRONT INSTALLATION
RIGHT (PASSENGER) SIDE SHOWN



(A LUVERNE Company)

1200 E. Birch St.

Brandon, SD 57005

fig. 1

REV C 23DEC11
REV B 28SEP10
REV A 28JUL10
550235 SHEET 3 16APR10

2011+ SUPER DUTY

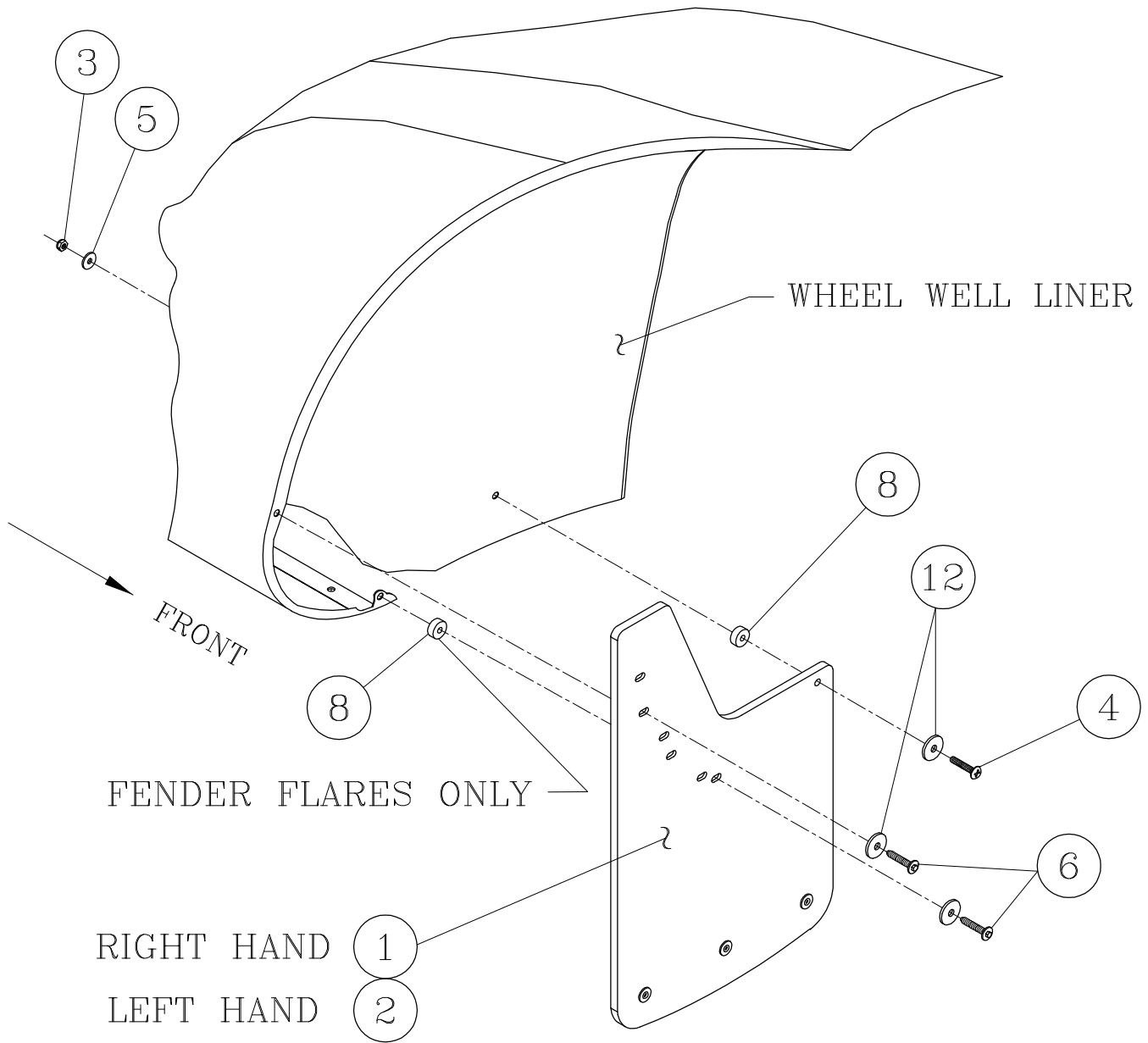

FRONT INSTALLATION
RIGHT (PASSENGER) SIDE SHOWN



(A LUVERNE Company)

1200 E. Birch St.

Brandon, SD 57005

fig. 2

REV C 23DEC11
REV B 28SEP10
REV A 28JUL10
550235 SHEET 4 16APR10

2011 SUPER DUTY (DRIVERS SIDE)

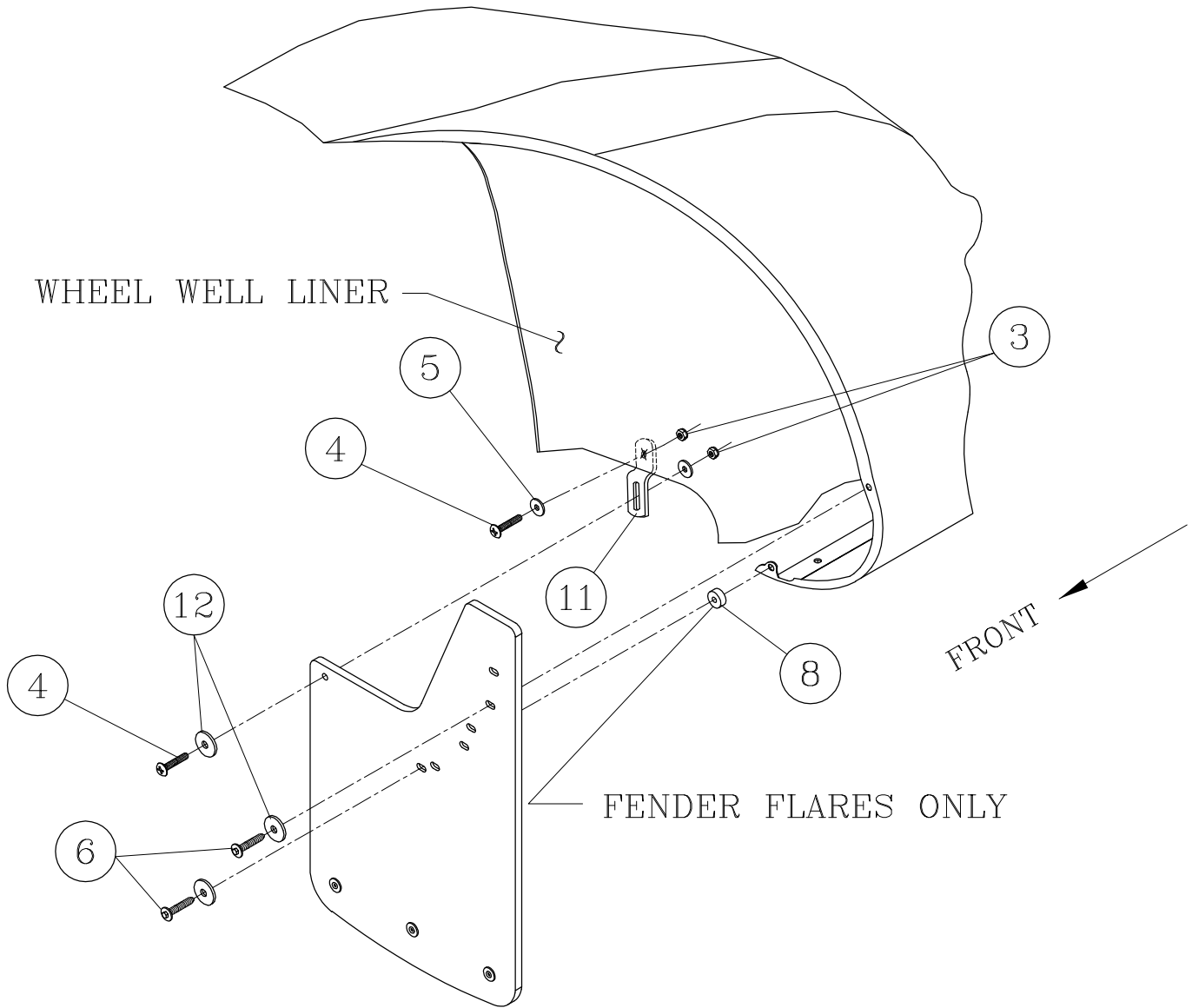

FRONT INSTALLATION
LEFT (DRIVER) SIDE SHOWN



(A LUVERNE Company)

1200 E. Birch St.

Brandon, SD 57005

fig. 3

REV C 23DEC11
REV B 28SEP10
REV A 28JUL10
550235 SHEET 5 16APR10

08-10 SUPER DUTY

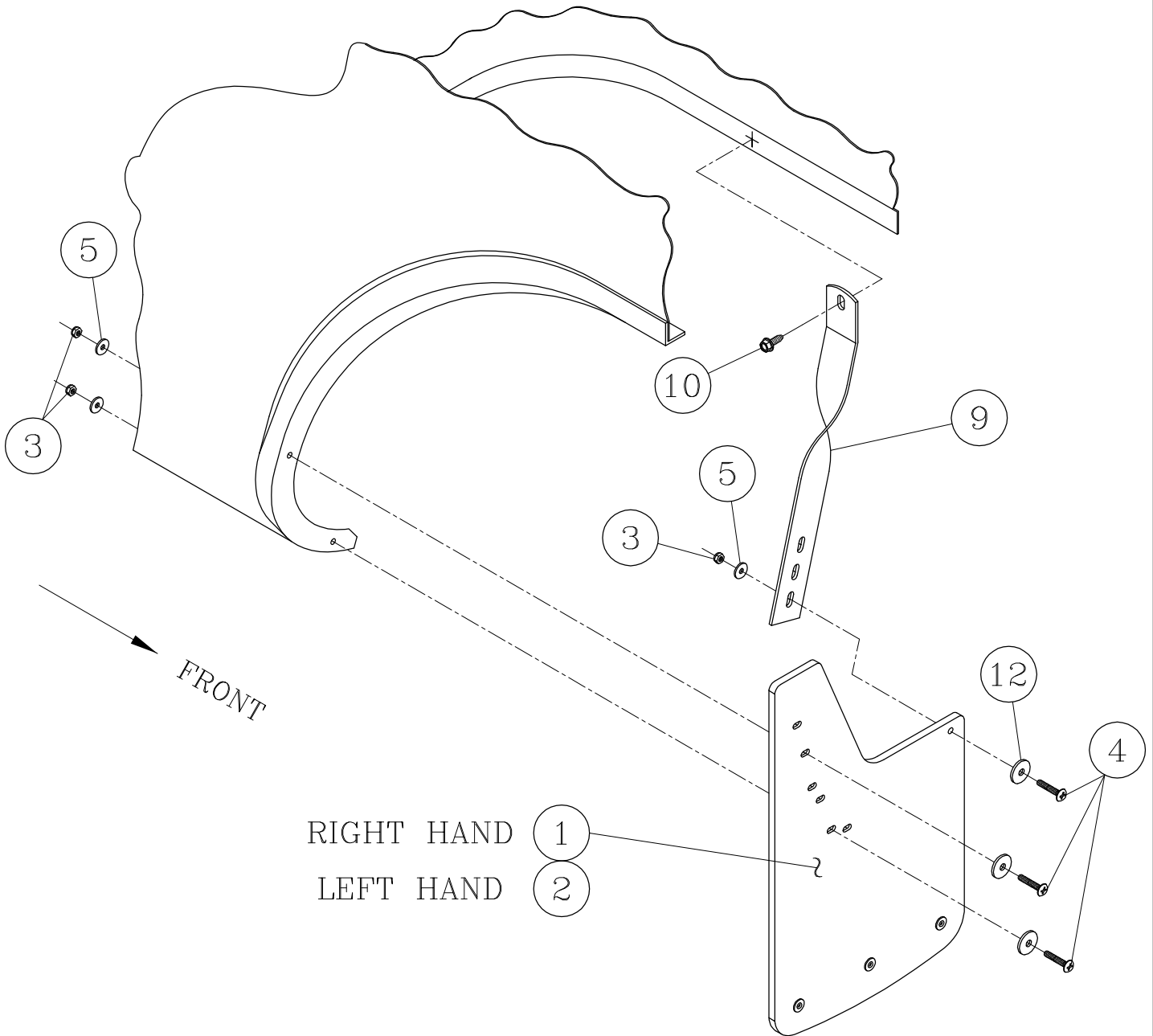

REAR INSTALLATION
RIGHT (PASSENGER) SIDE SHOWN



(A LIVERNE Company)

1200 E. Birch St.

Brandon, SD 57005

fig. 4

REV C 23DEC11
REV B 28SEP10
REV A 28JUL10
550235 SHEET 6 16APR10

2011+ SUPER DUTY

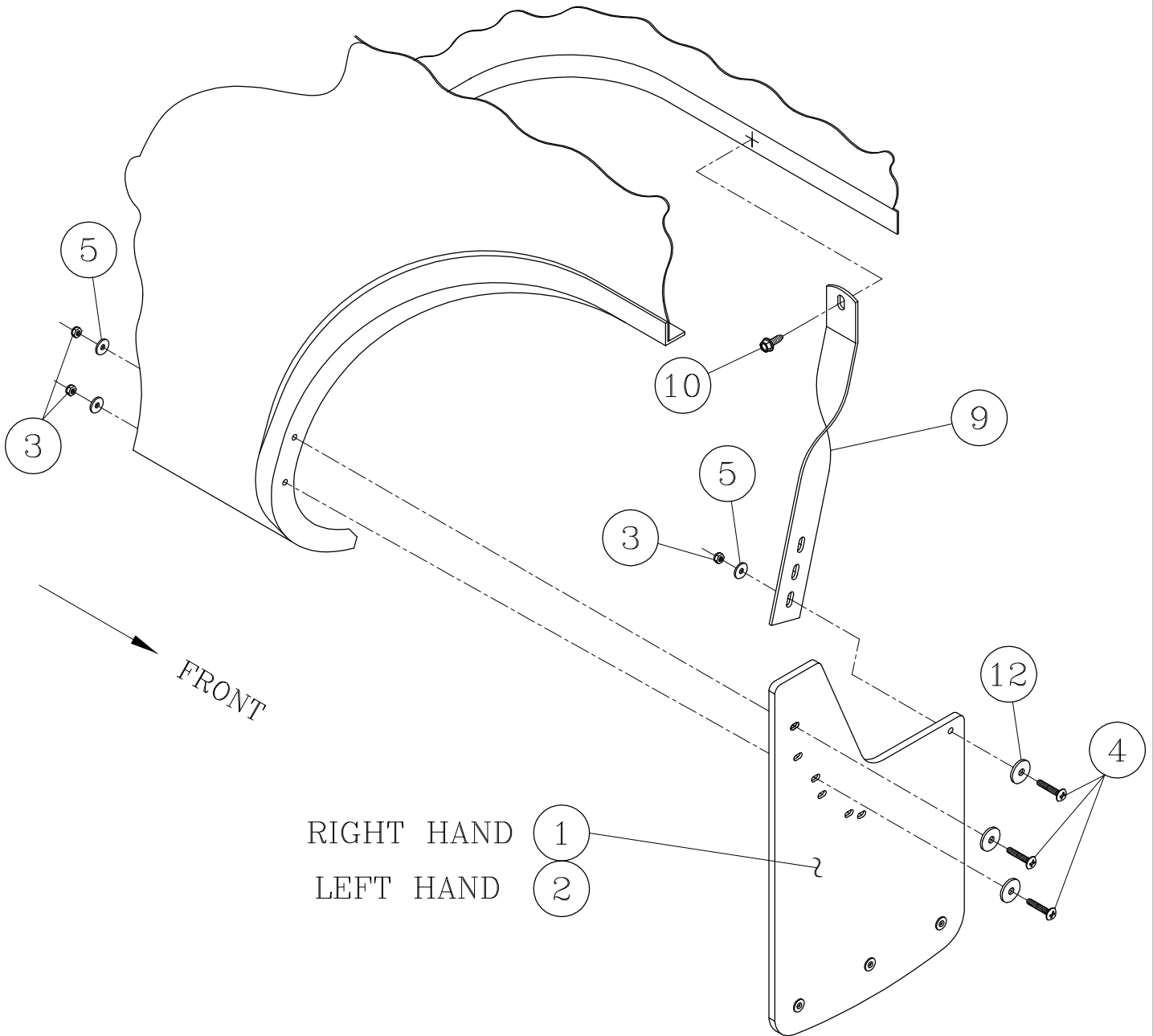

RIGHT HAND 1
LEFT HAND 2

REAR INSTALLATION
RIGHT (PASSENGER) SIDE SHOWN



(A LUVERNE Company)

1200 E. Birch St.

Brandon, SD 57005

fig. 5

REV C 23DEC11
REV B 28SEP10
REV A 28JUL10
550235 SHEET 7 16APR10