

INSTALLATION INSTRUCTIONS AND PARTS LIST

VEHICLE APPLICATION:

MODEL 251441 (12.00" X 20.00")

MODEL 251444 (12.00" X 23.00")

FRONT RUBBER SPLASH GUARDS

2019 GM PICKUPS

1. READ INSTRUCTIONS COMPLETELY AND CHECK TO MAKE SURE THAT ALL REQUIRED PARTS (LISTED ON SERVICE PARTS LIST) ARE ON HAND BEFORE STARTING THE INSTALLATION.
2. TAKE THE NO DRILL CLIPS (ITEM #3) AND MULTI THREAD U-NUTS (ITEM #4) AND A SPLASH GUARD AND ASSEMBLE AS FOLLOWS STARTING WITH THE TOP HOLE ASSEMBLE THE ¼ SCREW (ITEM #5) AND ¼ WASHER (ITEM #7) THROUGH THE SPLASH GUARD AND INTO THE CLIP. **DO NOT TIGHTEN ALL THE WAY.**
3. INSTALL THE SPLASH GUARDS AS FOLLOWS:
 - 3.1 REMOVE TWO FACTORY HEX HEAD SEMS SCREWS (**THESE SCREWS ARE NOT REUSED**).
 - 3.2 POSITION THE SPLASH GUARD AGAINST THE WHEEL WELL FLANGE AND HOOK THE CLIP BEHIND IT WITH THE SERRATED EDGE ON THE WHEEL WELL FLANGE. TIGHTEN FINGER TIGHT.
 - 3.3 INSTALL TWO HEX HEAD SEMS SCREWS (ITEM #8) THROUGH THE TWO LOWER HOLES.
 - 3.4 LOCATE THE SPLASH GUARD IN OR OUT AS DESIRED, LEVEL THE SPLASH GUARD AND TIGHTEN THE FASTENERS
 - 3.5 DRILL A ¼ HOLE AND INSTALL A ¼ SCREW (ITEM #5), ¼" WASHER (ITEM #7) AND NUT (ITEM #6) THROUGH WHEEL LINER AS SHOWN.



SERVICE PARTS LIST

2019 CHEVY PICKUPS
 MODEL NO. - 251441 & 251444

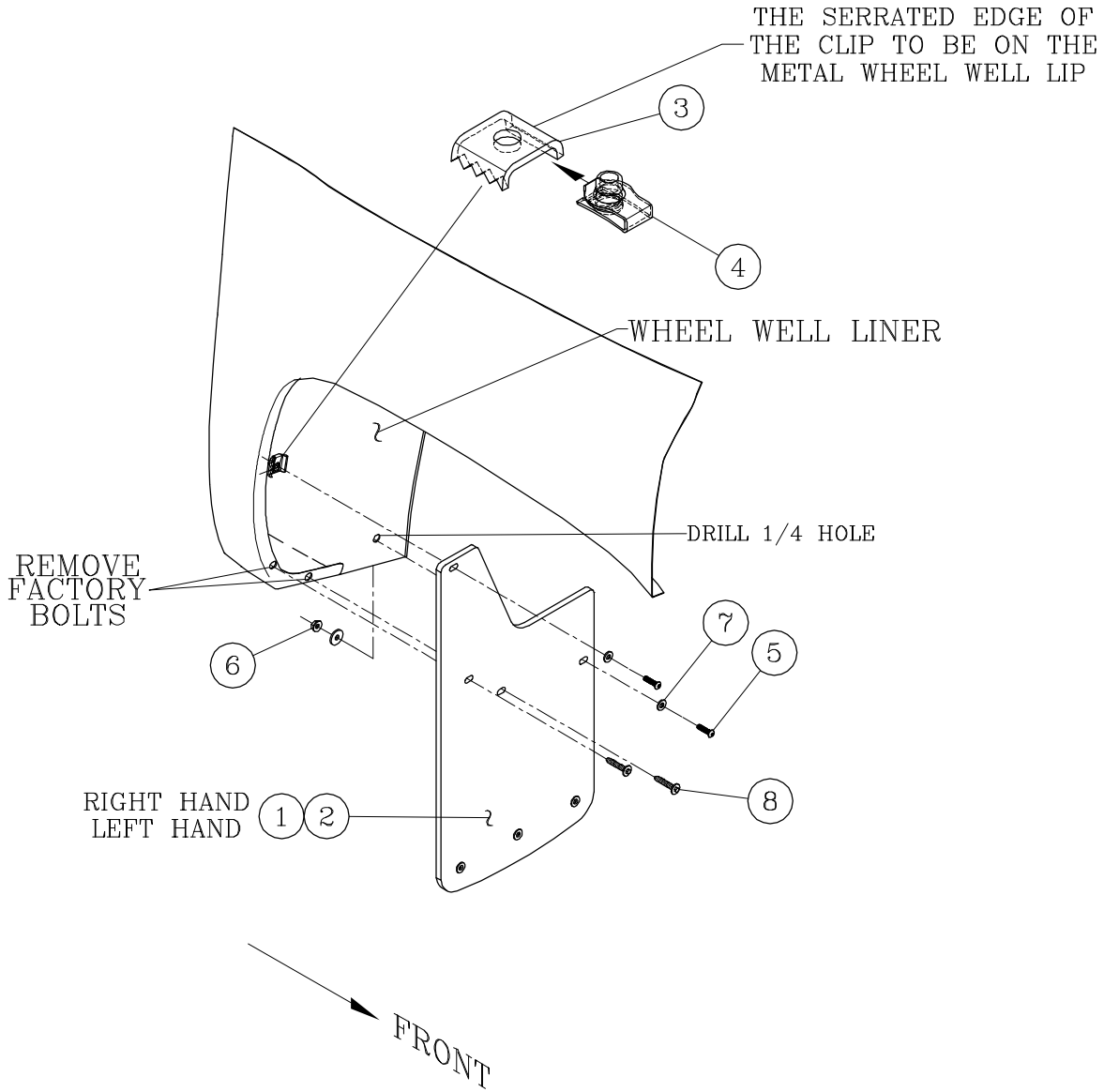

fig.1

FRONT INSTALLATION
 RIGHT (PASSENGER) SIDE SHOWN

ITEM	QTY	DESCRIPTION
1	1	SPLASH GUARD-RUBBER,12 X 20,19,GM PICKUPS,RH
2	1	SPLASH GUARD-RUBBER,12 X 20,19,GM PICKUPS,LH
1	1	SPLASH GUARD-RUBBER,12 X 23,19,GM PICKUPS,RH
2	1	SPLASH GUARD-RUBBER,12 X 23,19,GM PICKUPS,LH
3	2	BRACKET - NO DRILL CLIP, 07 GM PICKUP
4	2	MULTI THREAD U-NUT - 1/4-20
5	4	SCREW- BTN HD SOC, SST, 1/4-20 X 1.0"
6	2	NUT-HEX,NYL, 1/4-20,SST
7	6	WSHR-FNDR, 1/4 X1, SST,18-8,BZP
8	6	SCR-SEMS,7MMHH,M4.2-1.41X30MM

