

INSTALLATION MANUAL

3025173

This is the first of two manuals required to complete this installation. The second manual is included with your side bars / running boards.

Level of Difficulty

Moderate

Installation difficulty levels are based on time and effort involved and may vary depending on the installer level of expertise, condition of the vehicle and proper tools and equipment.

Parts List

2	Mounting bracket, front
2	Mounting bracket, rear
4	T-rails
8	Hex bolt, 1/4"
8	Flat washer, 1/4"
8	Nylock nut, 1/4"
8	Nylock nut, 5/16"
4	Hex bolt, M8 x 24.5mm
8	Flat washer, M8
4	Lock washer, M8
4	Fender washer, M8
4	Door sensor
2	Magnet
2	Alcohol wipe
1	Power switch
1	Circuit board
1	Anti-seize
1	Wire loom
1	Wiring harness, two-piece
2	LED light
2	LED light bracket
8	Double-sided foam tape, 3/4" x 3/4"
8	Double-sided foam tape, 1/2" x 1/2"
2	Rubber grommet, 1"

* Running boards sold separately

Product Registration and Warranty

ARIES stands behind our products with industry-leading warranties. To get copies of the product warranties, register your purchase or provide feedback, visit: warranty.curtgroup.com/surveys

⚠ WARNING

Improper electrical installation may result in personal injury. Unless you are familiar with the installation and handling of electrical systems, have this step performed by someone who has that familiarity.

Product Photo



⚠ CAUTION

If the step fails to actuate completely (open or closed), do not attempt to force the step open or close. Applying force in this condition will damage the product and void your warranty. Refer to the troubleshooting guide on the last page of the instruction manual to resolve potential issues.

NOTICE

Visit www.ariesautomotive.com for a full-color copy of this instruction manual, as well as helpful videos, guides and much more!

Before you begin installation, read all instructions thoroughly.

Proper tools will improve the quality of installation and reduce the time required.

ActionTrac™ Powered Running Boards feature a transportation mode cutoff switch to prevent battery drain. Switch to the off position if your vehicle is sitting idle for longer than one week.

Periodic inspection of your product should be performed to ensure all wiring connections, hardware and / or components remain secure.

To help prevent damage to the product or vehicle, refer to the specified torque specifications when securing hardware during the installation process.

Maintenance

No maintenance required on waterproof harness or water-resistant motors. If mud or dirt is built up on the steps, simply spray them off and let them air dry.

Mild automotive detergent may be used to clean the product. Do not use dish detergent, abrasive cleaners, abrasive pads, wire brushes or other similar products that may damage the finish.

Torque Specifications

1/4" bolt	3 ft.-lbs.
M8 bolt	7 ft.-lbs.
5/16" bolt	7 ft.-lbs.

Use above torque setting unless otherwise noted

Tools Required

Ratchet	Drill
Socket set	Drill bit set
Zip ties	Level

Step 1

Starting on the passenger side, locate the two mounting locations underneath the vehicle.

Note: Each bracket is specific to a mounting location. Refer to page 1 product image for correct locations.

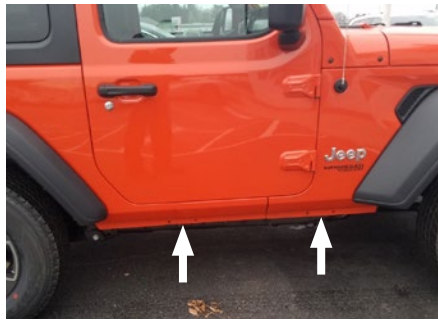

Step 2

Starting at the front passenger-side mounting location, attach the mounting bracket through the two holes on the vehicle rocker panel using two 1/4" flat washers and 1/4" nylock nuts.

Once the bracket is attached, mount one M8 bolt, M8 lock washer and the larger M8 fender washer with anti-seize.

Snug the hardware, but do not fully tighten.

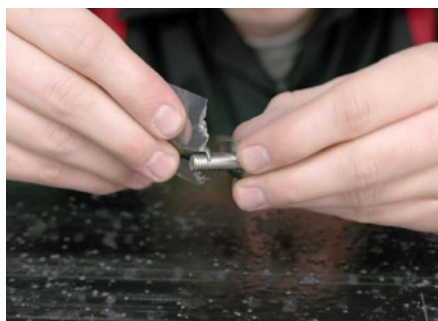
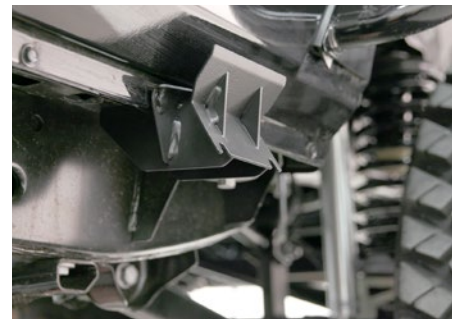

Step 3

Repeat step 2 for the rear bracket.

Repeat this entire process on the passenger side of the vehicle.

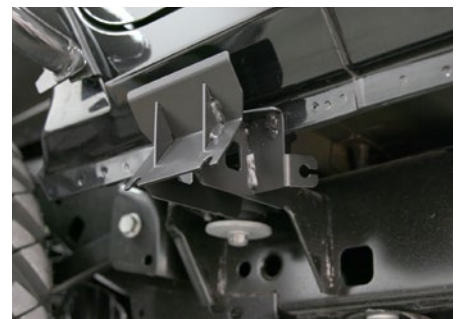

Step 4

Remove the fuse from the wiring harness before installing.

Once the fuse is removed, take that section of the wiring harness and attach it to the battery. Route the opposite end of the harness through the firewall into the cab of the vehicle.

Use a cable tie to secure the wiring harness in place once it is in the desired location.

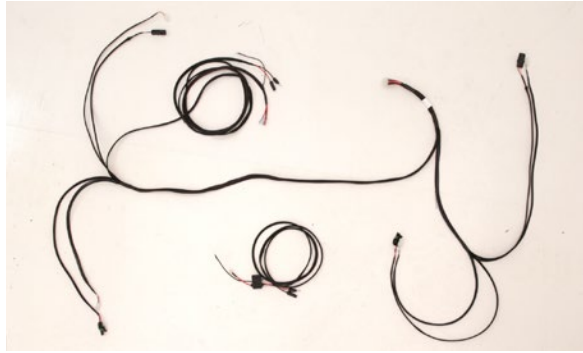

Step 5

Remove the fasteners securing the door trim panels on both sides of the vehicle.

Note: It may be easier to move the seats all the way back when removing the trim panel



Step 6

Once the trim panels are removed, take the second section of wiring harness and route it under the carpet, through the vehicle, from the passenger-side rear to the desired location.

Refer to the diagrams below.

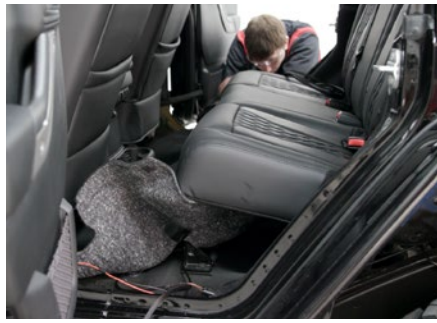

Wiring Locations

	Driver	Passenger
Door sensor, rear	Purple / Orange	Purple / Orange
Door sensor, front	Yellow / Orange	Yellow / Orange
LED light	Brown / Dark brown	Brown / Dark brown
Actuator	Black / Red	Black / Red
Door sensor, rear	White / Blue	White / Blue
Door sensor, front	Grey / Green	Grey / Green
LED light	Pink / Brown	Pink / Brown
Actuator	Black / Red	Black / Red

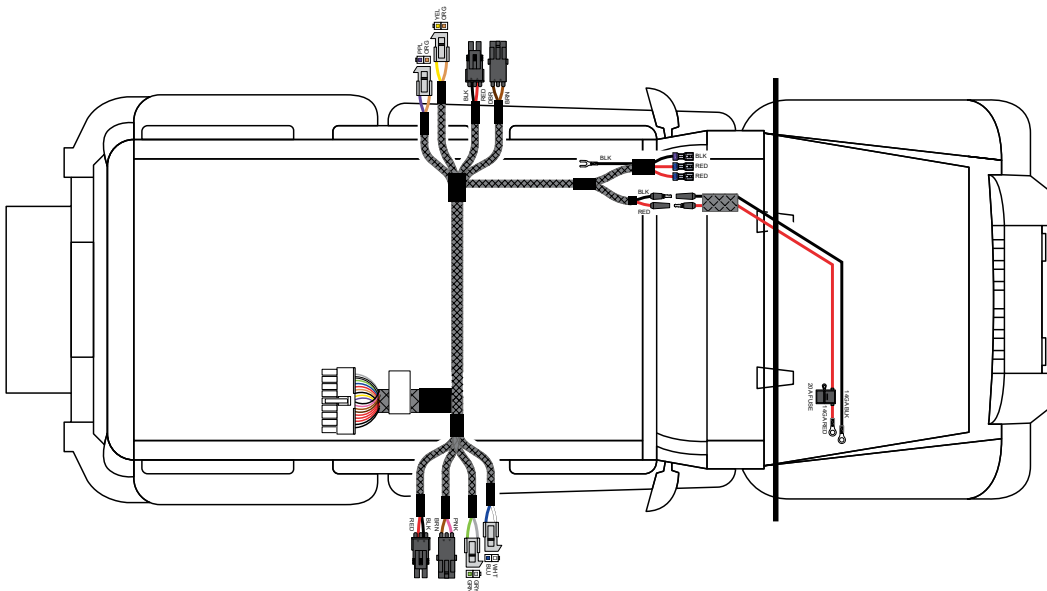
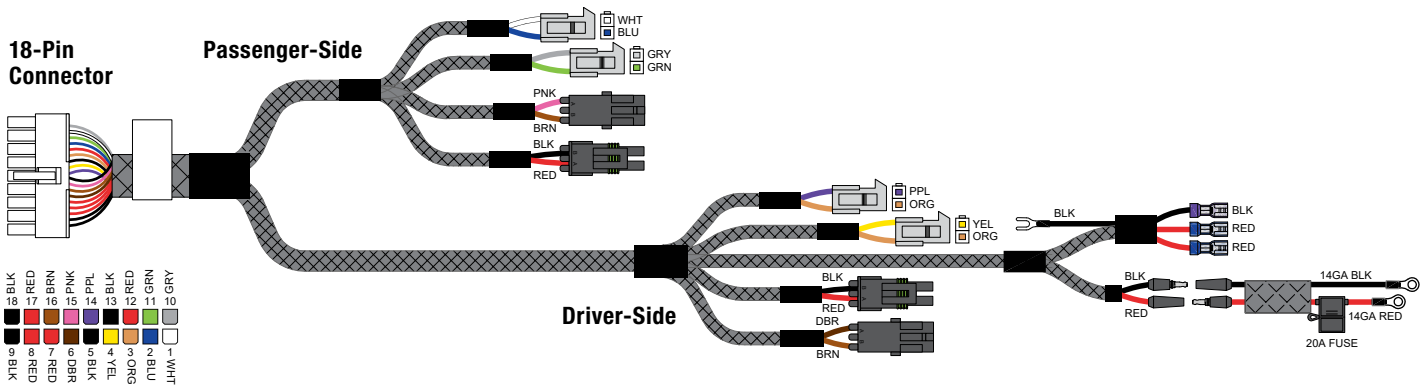

Step 7

On the driver side, take the power wire and sensor wire (orange / yellow) and route it to the front of the vehicle underneath the carpet.

Take the driver-side rear actuator (red / black) and the LED light (brown / tan) and route it through the floor plug behind the driver seat.

Note: If there is not plug in the floor behind the driver seat, locate a position close to the rear bracket and drill a 1" hole through the floor of the vehicle.

⚠ WARNING

Make sure there are no obstructions in the drilling location.

Once the hole is drilled take the driver-side rear actuator (red/black) and the LED light (brown/tan) and route it down through the floor. Secure in place with the provided rubber grommet.



Step 8

On the passenger side, take the sensor wire (gray / green) and route it to the front of the vehicle underneath the carpet.

Take the passenger-side rear actuator (red / black) and the LED light (pink / tan) and route it through the floor plug behind the passenger seat.

Note: If there is not plug in the floor behind the driver seat, locate a position close to the rear bracket and drill a 1" hole through the floor of the vehicle.

⚠ WARNING

Make sure there are no obstructions in the drilling location.

Once the hole is drilled take the passenger-side rear actuator (red/black) and the LED light (pink/tan) and route it down through the floor. Secure in place with the provided rubber grommet.



Step 9

With the rear wires inserted through the floor hole, cut a slot in the floor plug and re-insert it into the hole.



Step 10

Plug the door sensor into the wiring harness and route it up the door frame, under the carpet.

Note: If installing a door delete switch, refer to part #3020000-INS at this time.

Once the harness and sensor are routed to the desired locations, wipe the sensor and door with the provided alcohol wipe. Place the double-sided tape on the sensor and attach the sensor to the vehicle in the shown locations.

Repeat this process for the passenger door.

Note: The wiring harness has two sensor plugs on each side of the vehicle to accommodate four door vehicles. In a two door application, either plug may be used. DO NOT plug a door sensor into the second harness plug. Route the unused plug underneath the carpet with the rest of the wiring harness. The provided electrical kit will also come with four door-sensors to accommodate four door vehicles, only two of these sensors are required for this application.

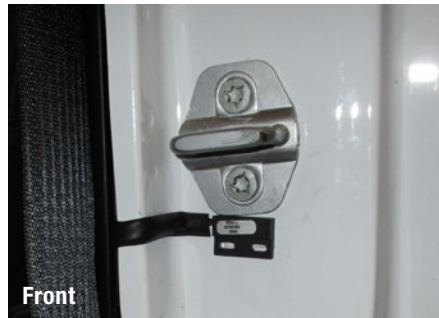
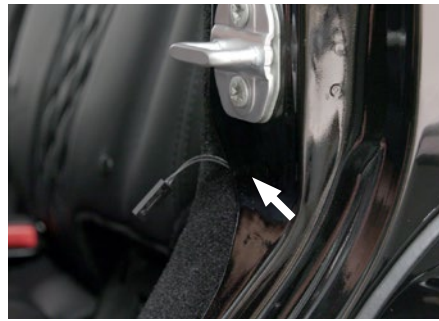

NOTICE

Use of the door delete switch (part #3020000) requires manual operation of the boards. Failure to retract the boards when operating the vehicle could result in damage to the boards or vehicle.

Step 11

Locate a spot to install the power switch. Drill a hole in the panel with a 3/4" drill bit and wire into place.

WARNING

Confirm there are no wires behind the panel prior to drilling.

NOTICE

Connect the two red wires to the silver terminals and the black wire to the bronze terminal.

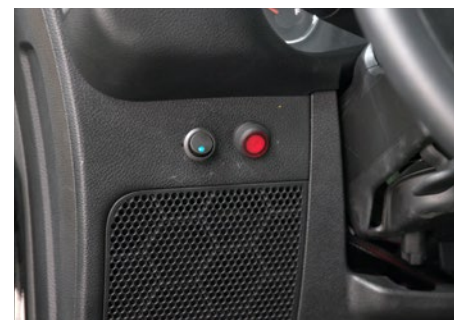
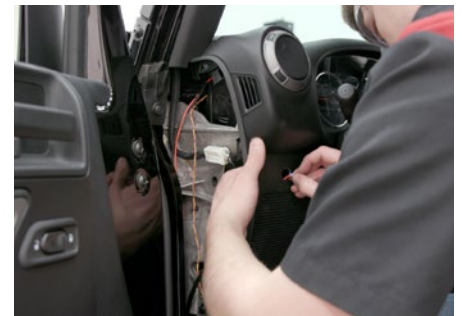

Step 12

Locate a suitable location to connect the ground wire for the LED on the switch behind the dash panel.



Step 13

Once all wiring is installed, plug in the circuit board and place it underneath the carpet in a suitable location. Ensure the control module will not interfere with seat movement after install.

Note: To complete the installation, refer to the manual included with your side bars / running boards.



TROUBLESHOOTING

Condition	Possible Cause	Possible Solutions	Additional Information
Boards do not open when the door is opened	Power switch is off	Confirm that the main power switch is in the on position and has power.	--
	Poor battery connection	Confirm the positive and negative connection on the battery are secure.	--
	Fuse is blown or removed	Confirm that the fuse is plugged in and not blown.	--
	Control module not connected	Confirm that the control module is plugged in.	--
	Board not connected	Confirm that the board connections are plugged in and secure.	--
	Door sensors not connected	Confirm that the door sensors are plugged in.	--
	Bad motor	Replace the board.	To check the motor function, apply 12 volts directly to the motor leads. If the board does not open, swap the leads and try again. If the board opens, the motor is good and swapping the leads back will cycle the board closed.
	Faulty control module	Replace the control module.	In rare cases, the programming of the control module may be faulty. Replace if the control module is receiving power but the boards are not functioning properly.
Boards open with the front/rear door, but not the other	Door sensor disconnected	Confirm that the door sensor is plugged in.	--
	Bad door sensor	Replace the sensor.	To check for a bad sensor, disconnect the sensor and check for continuity with a multi-meter. The sensor is normally a closed switch and should have continuity without the magnet present and should not have continuity when the magnet is placed near the sensor.
Board is open and will not close	Magnet misalignment	Adjust the magnet position.	Disconnect both sensors and the board should close. Connect only one door sensor and test. If the board closes, the alignment for that door is good. Connect the second sensor and repeat.
	Bad door sensor	Replace the sensor.	To check for a bad sensor, disconnect the sensor and check for continuity with a multi-meter. The sensor is normally a closed switch and should have continuity without the magnet present and should not have continuity when the magnet is placed near the sensor.
Boards squeak when opening/closing	Metal on metal contact	Apply graphite lubricant to all pivot points. 	If excessive squeaking still occurs, check for worn out bushings or obvious areas of metal on metal contact.
LED light does not turn on when the step is open	LED not connected	Confirm that the LED connection is plugged in and secure.	--
	Faulty LED	Inspect the LED and wiring harness for damage.	To test LED functionality, apply 12 volts directly to the LED. If the LED will not turn on when directly connected, it will need to be replaced.
Boards function opposite to how they should (door open board closed, door closed board open)	Incorrect sensors	Replace the sensors.	To check for an incorrect sensor, disconnect the sensor and check for continuity with a multi-meter. The sensor is normally a closed switch and should have continuity without the magnet present and should not have continuity when the magnet is placed near the sensor.
	Motor harness polarity reversed	Replace the board.	If sensors are confirmed to be correct (normally closed) and board still operates in reverse, the motor electrical harness may be reversed.
After quick succession of cycling the boards multiple times, the boards no longer open.	A programed safety limit has been reached.	Using the main switch, power off the boards for 5-10 seconds and turn back on. The boards should cycle when turned back on.	The LED will flash 8 times when this issue occurs.
Boards do not open when both front and rear doors are opened simultaneously	Software limitation	Close the doors and open them individually.	A software limitation will prevent the boards from opening if both the front and rear door are opened simultaneously. Closing the doors and opening them one at a time will reset the board.