

# INSTALLATION MANUAL

# 415102

## Level of Difficulty

Easy

Installation difficulty levels are based on time and effort involved and may vary depending on the installer level of expertise, condition of the vehicle and proper tools and equipment.

## Parts List

Item	Qty	Description
1	2	Grip step board
2	4	End cap
3	8	Self tapping screw
4	10	Embossed bracket
5	20	Carriage bolt 5/16-18 x 1
6	20	Serrated flange nut, 5/16-18
7	20	Flat washer, 5/16

## Tools Required

Drill	Phillips head drill bit
Wrench, 1/2"	--

## Torque Specifications

5/16" bolt	5 ft-lbs.
------------	-----------

Use above torque setting unless otherwise noted

## Product Registration and Warranty

LUVERNE stands behind our products with industry-leading warranties. To get copies of the product warranties, register your purchase or provide feedback, visit: [warranty.curtgroup.com/surveys](http://warranty.curtgroup.com/surveys)

## Product Photo

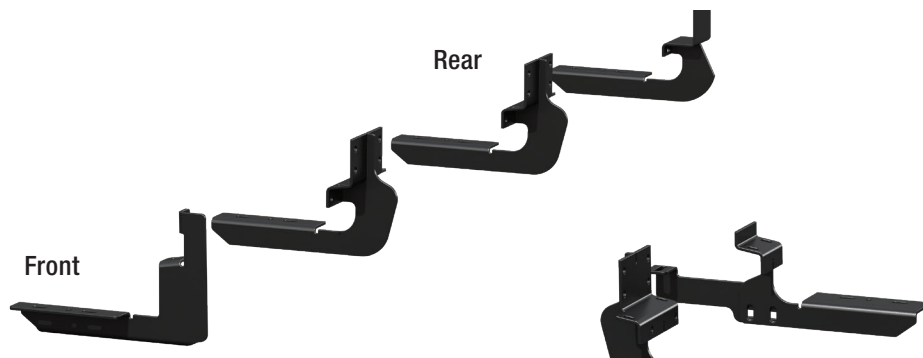

## NOTICE

Visit [www.luvernetruck.com](http://www.luvernetruck.com) for a full-color copy of this instruction manual, as well as helpful videos, guides and much more!

Before you begin installation, read all instructions thoroughly.

Proper tools will improve the quality of installation and reduce the time required.

Periodic inspection of your product should be performed to ensure all hardware and / or components remain secure.

To help prevent damage to the product or vehicle, refer to the specified torque specifications when securing hardware during the installation process.

**Ranch hand only:** Always disconnect the vehicle battery before removing sensors or disconnecting wiring harnesses. Ranch Hand is not responsible for sensor miscalibration or accidental deployment of airbags during installation.

**Ranch hand only:** Always mark the orientation of sensors prior to removal from the factory bumper. Many vehicle sensors are calibrated to a particular orientation, and reinstallation sideways or upside down will impact vehicle performance. A piece of masking tape, a grease pencil, or other mark to indicate the sensor's original orientation will help to ensure proper re-installation.

## Maintenance

Mild automotive detergent may be used to clean the product. Do not use dish detergent, abrasive cleaners, abrasive pads, wire brushes or other similar products that may damage the finish.

# INSTALLATION

## Step 1

Set the Grip Step board on the vehicle mounting brackets. Insert the appropriate number of embossed brackets into the Grip Step channel and align with the mounting brackets.

Using the 5/16 carriage bolts, flat washers, and serrated flange nuts, loosely attach the board to the brackets. Adjust the board front to back/in and out, then tighten all hardware to spec.

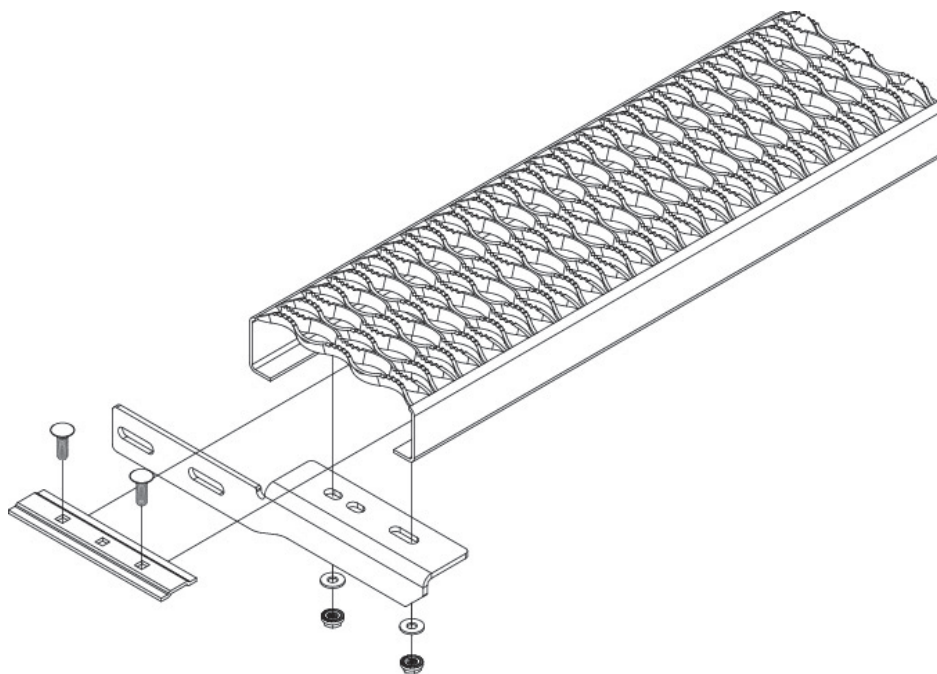

## Step 2

Slide the end cap over the ends of the board, attach using the self drilling screws.

