

# INSTALLATION INSTRUCTIONS AND PARTS LIST

## MODEL 570553 MEGA STEPS BRACKETS:

2005 AND NEWER TOYOTA TACOMA ACCESS AND DOUBLE CAB PICKUPS

2007 AND NEWER TOYOTA FJ CRUISER



1. READ INSTRUCTIONS COMPLETELY AND CHECK TO MAKE SURE THAT ALL REQUIRED PARTS (LISTED ON SERVICE PARTS LIST) ARE ON HAND BEFORE STARTING THE INSTALLATION.
2. EXISTING MOUNTING FASTENERS (M8-1.25 FACTORY NUTS WITH SLOTTED PLASTIC PLUGS) ARE LOCATED ON THE INCLINED INTERIOR SURFACES OF THE ROCKER PANEL. THESE MOUNTING FASTENERS ARE USED FOR THIS INSTALLATION PER THE FOLLOWING INSTRUCTIONS.
3. ATTACH THE MOUNTING BRACKETS (ITEM #2) TO THE VEHICLE.
  - 3.1. POSITION THE BRACKETS ON THE VEHICLE SO THAT THE HOLES IN THE BRACKETS LINE UP WITH THE WITH THE 8mm METRIC NUTS IN THE ROCKER PANEL. ATTACH THE BRACKETS WITH M8-1.25 X 25mm (APPROX. 1.00" LONG) ZINC PLATED HEX HEAD CAP SCREW (ITEM #5) AND 5/16" ZINC PLATED FLAT WASHER (ITEM #6).
  - 3.2. EACH FRONT BRACKET USES ONE SCREW AND WASHER AS SHOWN.
  - 3.3. EACH CENTER AND REAR BRACKET USES TWO SCREWS AND WASHERS AND ONE ADDITIONAL WASHER (ITEM #7), USED AS A SPACER, BETWEEN THE BRACKET AND THE ROCKER PANEL AS SHOWN.
4. ATTACH THE STEPS (ITEM #1) TO THE MOUNTING BRACKETS.
  - 4.1. INSERT THREE (3) 5/16" SQUARE HEAD SCREWS (ITEM #3) IN THE CENTER SLOT ON THE UNDER SIDE OF THE STEP.
  - 4.2. POSITION THE STEP ON THE MOUNTING BRACKETS SO THAT THE SQUARE HEAD SCREWS ARE LOCATED IN THE SLOTS OF THE MOUNTING BRACKETS AND THE STEP IS CENTERED FRONT TO REAR.
  - 4.3. LOCATE THE STEP, IN AND OUT, AS DESIRED, INSTALL 5/16" SERRATED FLANGE NUTS (ITEM #4) ON THE SQUARE HEAD SCREWS AND TIGHTEN TO 19 LB FT.
  - 4.4. INSTALL 5/16-18 SERRATED FLANGE NUTS (ITEM #4) ON ANY UNUSED SQUARE HEAD SCREWS IN THE INBOARD SLOT OF THE STEP AND TIGHTEN TO 19 LB FT.

## SERVICE PARTS LIST

ITEM	PART NO.	QTY	DESCRIPTION
1		2	MEGA STEP BOARD ASSEMBLY- (SOLD SEPARATELY) LENGTH WILL VARY DEPENDING ON APPLICATION
2	551633	6	BRKT- MTG, MEGA STEP, RH/LH, TOYOTA TACOMA
3	106880	6	SCREW-SQUARE HEAD, 5/16_18 UNC
4	102680	14	NUT-SERRATED FLANGE, HEX, SST, 5/16-18 UNC
5	102549	10	SCREW- HEX HEAD CAP, M8-1.25 X 25mm,ZP
6	100034	10	WSHR-PL, A, STL, 5/16,.375 ID X .875 OD X .083 THK, ZP
7	100062	4	WSHR-PL, A, STL, 3/8,.438 ID X 1.00 OD X .083 THK, ZP

SERVICE PARTS LIST

ACCESS & DOUBLE CAB  
MODEL NO. - 570553

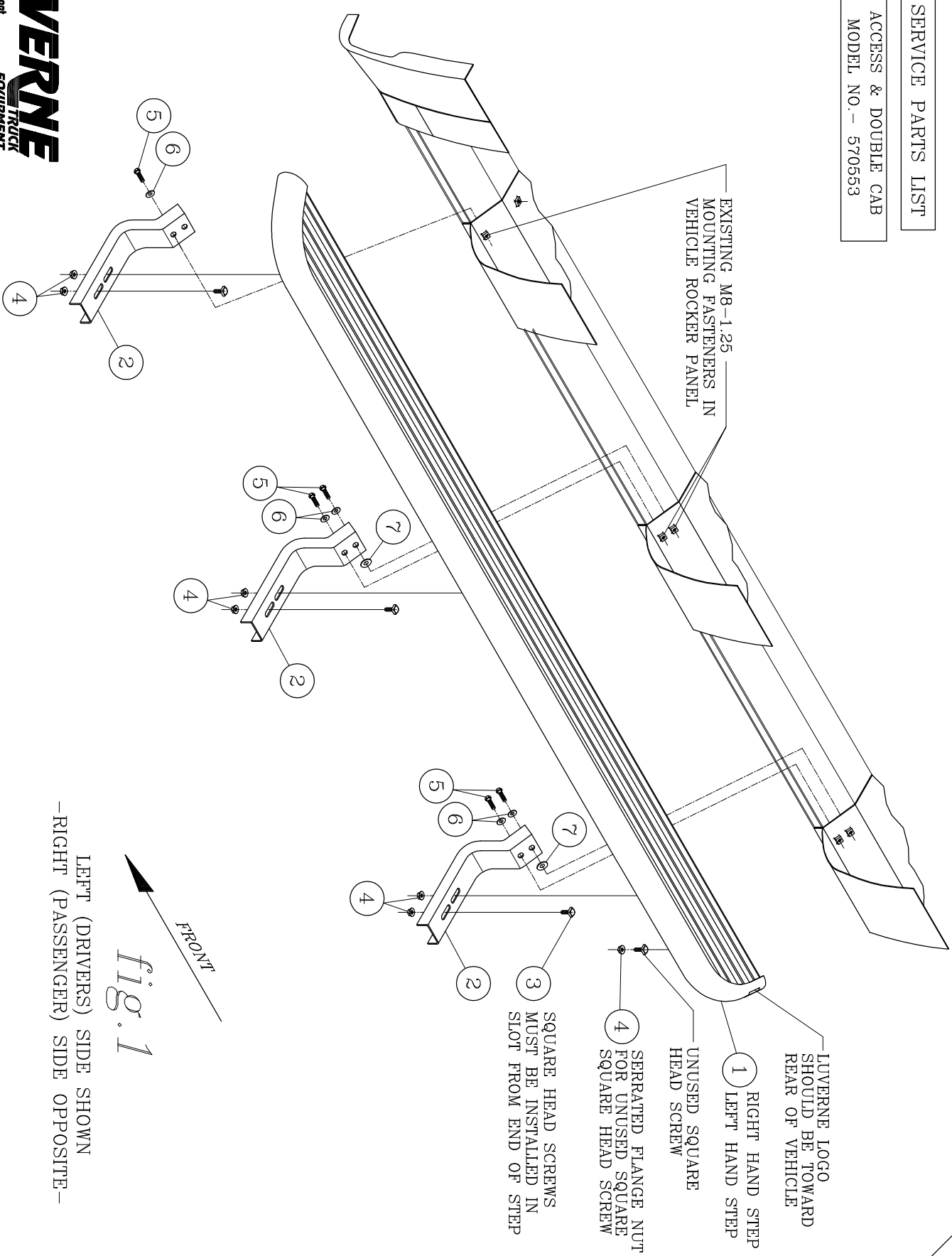

fig. 1

LEFT (DRIVERS) SIDE SHOWN  
-RIGHT (PASSENGER) SIDE OPPOSITE-