

INSTALLATION INSTRUCTIONS AND PARTS LIST

MODEL 570713 MEGA STEPS

VEHICLE APPLICATION: 2007 GM SILVERADO & SIERRA CREW CAB PICKUPS
2007 AND NEWER GM TAHOE & SUBURBAN WITHOUT FACTORY SIDE STEPS
2007 CHEVY AVALANCHE WITHOUT FACTORY SIDE STEPS
2007 GM SILVERADO&SIERRA EXT CAB



1. READ INSTRUCTIONS COMPLETELY AND CHECK TO MAKE SURE THAT ALL REQUIRED PARTS (LISTED ON SERVICE PARTS LIST) ARE ON HAND BEFORE STARTING THE INSTALLATION. SEE ATTACHED DRAWING FOR VEHICLE APPLICATION YOU REQUIRE.
2. ATTACH THE TOP OF THE MOUNTING BRACKETS TO THE VEHICLE WITH (ITEM#3) – (U-NUT AND BOLT OR FLANGED NUT MAY NEED TO BE USED. SEE ATTACHED DRAWINGS FOR SPECIFIC VEHICLE APPLICATION)
3. INSERT A NYLON WASHER (ITEM #2) BETWEEN THE TOP OF THE MOUNTING BRACKET AND THE BOTTOM OF THE ROCKER PANEL AND INSTALL THE SCREW (ITEM#3) AND WASHER (ITEM#7) AND NUT (ITEM#8) PLACE PINCH WELD SUPPORT BRACKET ABOVE PINCH WELD AREA. AS SHOWN. -(UNLESS THREADED)-THIS IS DONE ON EACH MOUNTING BRACKET.TIGHTEN TO 19 LB FT.THE DISTANCE BETWEEN THE FRONT BRACKET AND 2ND BRACKET WILL BE 24 INCHES.
4. PREPARE THE MEGA STEP PLATE FOR MOUNTING AS FOLLOWS.INSERT THREE (3) 5/16” SQUARE HEAD SCREWS (ITEM #5) IN THE CENTER SLOT ON THE UNDER SIDE OF THE STEP.
5. POSITIONS THE MEGA STEP ON THE MOUNTING BRACKETS SO THAT THE SQUARE HEAD SCREWS ARE LOCATED IN THE SLOTS OF THE MOUNTING BRACKETS AND THE STEP IS CENTERED, FRONT TO REAR, ON THE VEHICLE. INSTALL 5/16” SERRATED FLANGE NUTS (ITEM #4) ON THE SQUARE HEAD SCREWS AND TIGHTEN TO 19 LB FT.

SERVICE PARTS LIST

ITEM	PART NO.	QTY	DESCRIPTION
1	575078	1	STEP ASSY- 78.00” (MOD. 575078) TAHOE& EXT CAB
1	575088	1	STEP ASSY-88.00” (MOD. 575088) SUBURBAN & CREW CAB
2	107182	6	WASHER- SPCR, NYLON, BLK, .312 ID X 1.24 OD X .25 THK
3	100180	12	M8 X 30 X1.25 SCR,SST,BZP
4	102680	14	NUT-SERRATED FLANGE, HEX, SST, 5/16-18 UNC
5	106880	6	SCREW-SQUARE HD,5/16-18UNC X 1.00”
6	551746	6	MOUNTING BRACKET,MEGASTEP
7	102734	12	5/16” STD FLAT WASHER SST
8	105859	6	M8 FLANGED NUT ZP
9	100647	6	5/16” X 1.00” SCR ZP
10	105541	6	U-NUT 5/16” - 18
11	551666	6	BRKT-MTG,PINCH WELD SUPPORT

LIVERNE
ISO9001 QS9000 CERTIFIED TRUCK
EQUIPMENT
1200 Birch Street
Brandon, SD 57005
INC.

551741 SHEET 1 31OCT06
REVISION A 08NOV06
REVISION B 26MAR07
REVISION C 23OCT07
REVISION D 20OCT08

LUVERNE LOGO SHOULD BE TOWARD REAR OF VEHICLE

SILVERADO / SIERRA

SERVICE PARTS LIST

MODEL NO. -570713

NOTE:
 THE MOUNTING PATTERNS MAY NOT BE EXACTLY AS SHOWN. HOWEVER THERE WILL BE ENOUGH FASTENERS TO MAKE THE APPLICATION. THE DISTANCE BETWEEN THE FIRST AND SECOND BRACKET WILL BE 24 INCHES.

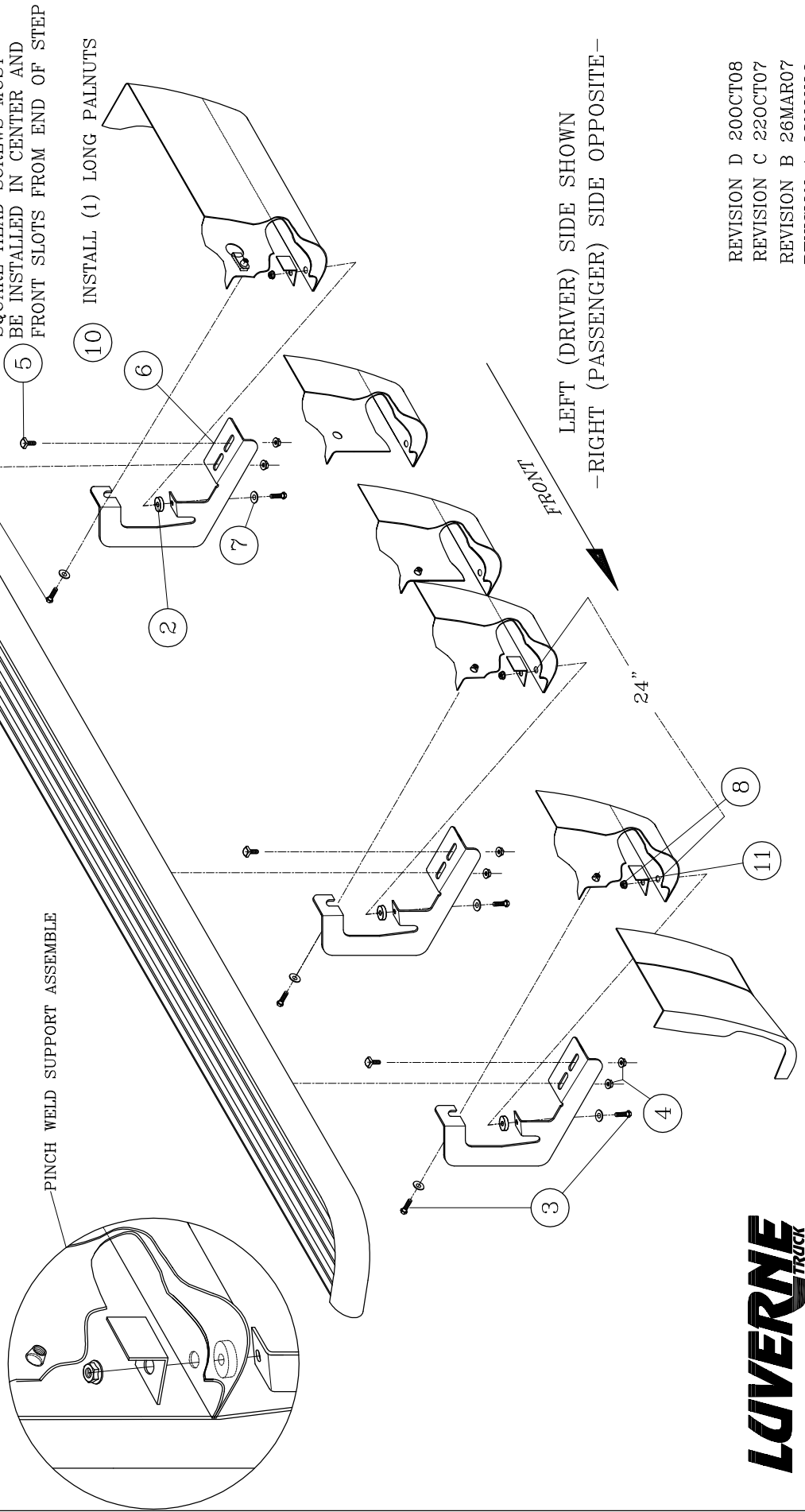

REVISION D 20OCT08
 REVISION C 22OCT07
 REVISION B 26MAR07
 REVISION A 08NOV06
 551741 SHEET 2 31OCT06

LUVERNE
 TRUCK
 EQUIPMENT
 INC.
 1200 Birch Street
 Brandon, SD 57005

LUVERNE LOGO SHOULD BE TOWARD REAR OF VEHICLE

SUBURBAN / TAHOE

SERVICE PARTS LIST

MODEL NO. -570713

NOTE:
THE MOUNTING PATTERNS MAY NOT BE EXACTLY AS SHOWN. HOWEVER THERE WILL BE ENOUGH FASTENERS TO MAKE THE APPLICATION. THE DISTANCE BETWEEN THE FIRST AND SECOND BRACKET WILL BE 24 INCHES.

1 RIGHT HAND STEP
LEFT HAND STEP

SQUARE HEAD SCREWS MUST BE INSTALLED IN CENTER AND FRONT SLOTS FROM END OF STEP

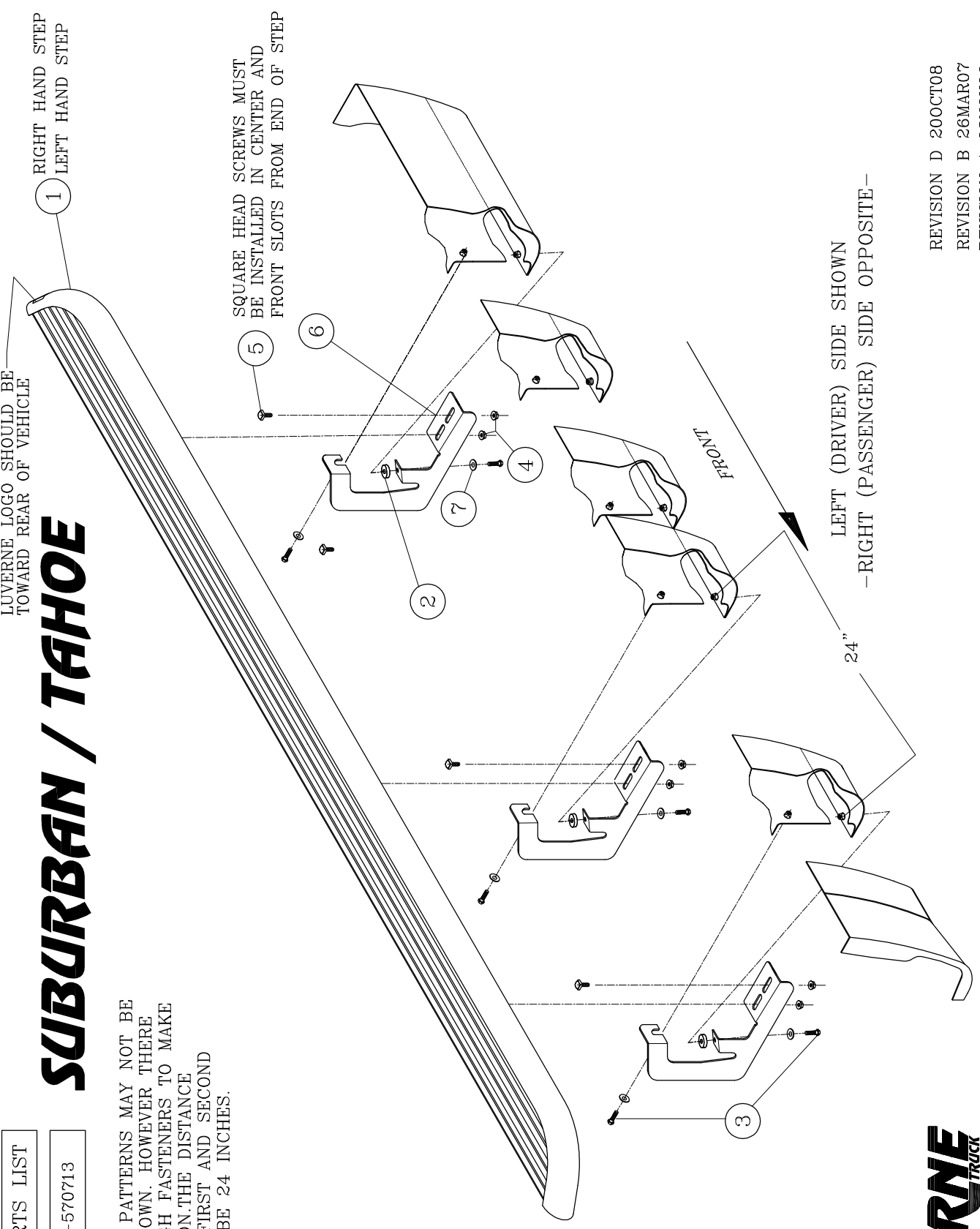

LUVERNE
TRUCK
EQUIPMENT
INC.

1200 Birch Street
Brandon, SD 57005

REVISION D 200CT08
REVISION B 26MAR07
REVISION A 08NOV06
551741 SHEET 3 310CT06

SERVICE PARTS LIST

MODEL NO. -570713

AVALANCHE

NOTE:
THE MOUNTING PATTERNS MAY NOT BE EXACTLY AS SHOWN. HOWEVER THERE WILL BE ENOUGH FASTENERS TO MAKE THE APPLICATION. THE DISTANCE BETWEEN THE FIRST AND SECOND BRACKET WILL BE 24 INCHES.

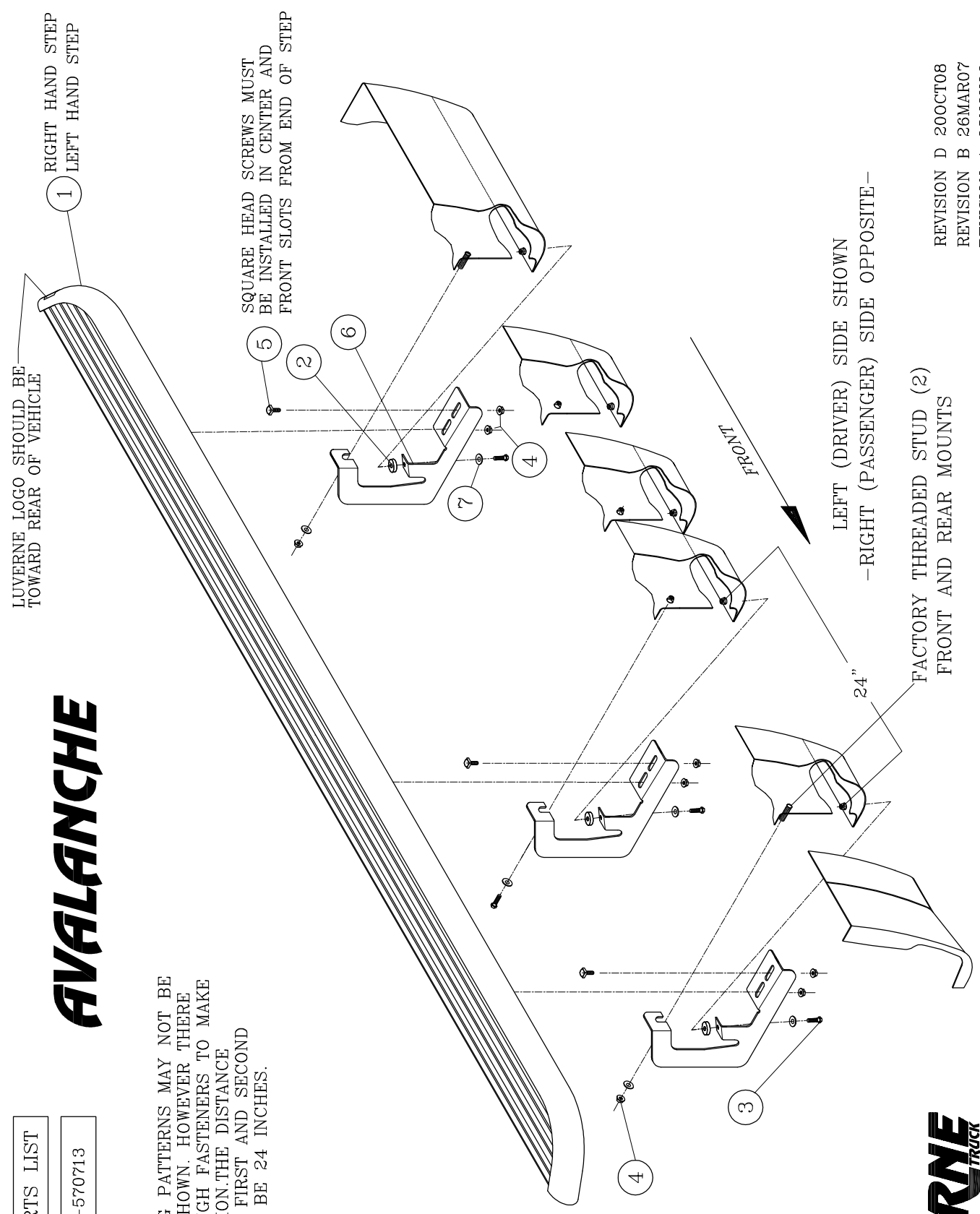

LUVERNE
TRUCK
EQUIPMENT
INC.
1200 Birch Street
Brandon, SD 57005

REVISION D 20OCT08
REVISION B 26MAR07
REVISION A 08NOV06
551741 SHEET 4 31OCT06