

INSTALLATION INSTRUCTIONS AND PARTS LIST

APPLICATION: MODEL 571113 MEGA STEP BRACKETS:
2011 AND NEWER GM EXTENDED, AND CREW CAB PICKUPS



1. READ INSTRUCTIONS COMPLETELY AND CHECK TO MAKE SURE THAT ALL REQUIRED PARTS (LISTED ON SERVICE PARTS LIST) ARE ON HAND BEFORE STARTING THE INSTALLATION.
2. ASSEMBLE THE LOAD REACTION STUDS AND HARDWARE (ITEM #11 THRU #14) AS FOLLOWS.
 - 2.1. ON THE SHORT THREADED END OF THE LOAD REACTION STUD (ITEM #14), INSTALL A BLACK 3/8" SERRATED FLANGE NUT (ITEM #13) BACKWARDS TO THE BOTTTOM OF THE THREAD. THEN, INSTALL A BLACK 3/8" FLAT WASHER (ITEM #12) AND RUBBER "CUSHION" WASHER (ITEM # 11) TIGHT UP AGAINST THE SERRATED FLANGE NUT. (THE END OF THE STUD MUST BE RECESSED IN THE RUBBER WASHER APPROX. 3/16").
 - 2.2. ON THE LONG THREADED END OF THE STUD, INSTALL A BLACK 3/8" SERRATED FLANGE NUT (ITEM # 13) BACKWARDS TO NEAR TO THE BOTTTOM OF THE THREADS
3. ATTACH THE LOAD REACTION STUD ASSEMBLIES TO THE BODY MOUNT BRACKETS AS SHOWN.
 - 3.1. INSERT THE STUD, FROM WHAT WILL BE IN THE INBOARD OR FRAME SIDE THRU THE LOWEST HOLE IN THE BENT FLANGE OF THE BODY BRACKETS THAT WILL ALLOW THE RUBBER WASHER TO SEAT FIRM AGAINST THE SIDE WALL OF THE FRAME. INSTALL A BLACK FLANGE NUT (ITEM #13) ON THE OUTBOARD END OF THE STUD (FINGER TIGHTEN).
 - 3.2. **IF YOU ARE MOUNTING THESE STEPS ON A 1500 TRUCK YOU WILL NEED TO ASSEMBLE THE LOAD REACTION BOLT TO THE FRONT BRACKETS AS SHOWN IN FIG. 1 USING THE SUPPLIED ANGLE BRACKET (ITEM #17).**

NOTE:

DUE TO EXCESSIVE THREAD LOCKER IN THE BODY MOUNT BOLT AREA ON THE 2010+ GM SILVERADO/SIERRA, USE CAUTION WHEN REMOVING THE BODY MOUNT BOLTS TO REDUCE THE RISK OF CAUSING DAMAGE TO THE THREADED INSERTS INSIDE THE VEHICLE.

4. REMOVE THE FACTORY FRONT, CENTER, AND REAR BODY MOUNT BOLTS (ONE SIDE OF THE VEHICLE AT A TIME) AND INSTALL THE MOUNTING BRACKETS AS FOLLOWS:
 - 4.1. INSTALL THE FRONT MTG BRKT (ITEM #2 & #3) TO THE FRONT CAB MOUNT AS SHOWN (LEAVE THESE FASTENERS FINGER TIGHT).
 - 4.2. INSTALL THE CENTER MTG BRKT (ITEM #4 & #5) TO THE CENTER CAB MOUNT AS SHOWN (LEAVE THESE FASTENERS FINGER TIGHT).
 - 4.3. INSTALL THE REAR INBOARD MTG BRKT (ITEM #8) & WASHER (ITEM #16) TO THE REAR CAB MOUNT AS SHOWN (LEAVE THESE FASTENERS FINGER TIGHT)

EXTENDED CAB ONLY

- 4.3.1. INSTALL THE REAR OUTBOARD CAB MTG BRKT (ITEM #6 & #7) TO THE REAR INBOARD CAB MTG BRKT (ITEM #8), WITH THE 3/8" BLACK ZINC PLATED BOLTS (ITEM # 15), WASHERS (ITEM #12) AND SERRATED FLANGE NUTS (ITEM # 13). THE REAR OUTBOARD CAB MTG BRKT MUST BE MOUNTED TO THE BACK SIDE OF THE REAR INBOARD CAB MTG BRKT (TOWARDS THE REAR OF THE VEHICLE) AS SHOWN. USING THE HOLES AS SHOWN IN FIG 2. TIGHTEN THESE BOLTS.



(A LIVERNE Company)

1200 E. Birch St.

Brandon, SD 57005

REV B 21MAY14

REV A 04JAN11

551911 SHEET 1 OF 4 21OCT10

CREW CAB ONLY

- 4.3.2. INSTALL THE REAR OUTBOARD CAB MTG BRKT (ITEM #6 & #7) TO THE REAR INBOARD CAB MTG BRKT (ITEM #8), WITH THE 3/8" BLACK ZINC PLATED BOLTS (ITEM # 15), WASHERS (ITEM #12) AND SERRATED FLANGE NUTS (ITEM # 13). THE REAR OUTBOARD CAB MTG BRKT MUST BE MOUNTED TO THE BACK SIDE OF THE REAR INBOARD CAB MTG BRKT (TOWARDS THE REAR OF THE VEHICLE) AS SHOWN. USING THE HOLES AS SHOWN IN FIG 3. TIGHTEN THESE BOLTS.
5. ATTACH THE STEP (ITEM #1) TO THE MOUNTING BRACKETS.
- 5.1 INSERT THREE [3] 5/16" SQUARE HEAD SCREWS (ITEM #9) IN THE CENTER SLOT ON THE UNDERSIDE OF THE STEP.
- 5.2 POSITION THE STEP ON THE MOUNTING BRACKETS SO THAT THE SQUARE HEAD SCREWS ARE LOCATED IN THE CENTER TWO (2) SLOTS OF THE BRACKETS. (SEE FIG 2, OR 3) CENTER THE STEP ON THE CAB FRONT TO BACK.
- 5.3 LOCATE THE STEP IN AND OUT AS DESIRED AND INSTALL THE 5/16" SERRATED FLANGE NUTS (ITEM #10) ON THE SQUARE HEAD SCREWS. TIGHTEN THE NUTS.
6. ADJUST AND TIGHTEN THE LOAD REACTION STUDS AND HARDWARE AS FOLLOWS.
ADJUST THE STUD ASSEMBLY SO THAT THE RUBBER WASHER IS FIRM AGAINST THE SIDE OF THE FRAME AND TIGHTEN THE FLANGE NUTS ON EITHER SIDE OF THE STEP MOUNTING BRACKET FLANGE.

TIGHTEN THE BODY MOUNT BOLTS PER MANUFACTURERS SPECS.

SERVICE PARTS LIST

ITEM	PART NO.	QTY	DESCRIPTION
1		2	MEGA STEP BOARD ASSEMBLY (SOLD SEPARATELY) LENGTH WILL VARY DEPENDING ON APPLICATION
2	551901	1	BRACKET-MTG, CAB, FRONT, LH, 571113
3	551904	1	BRACKET-MTG, CAB, FRONT, RH, 571113
4	551902	1	BRACKET-MTG, CAB,CENTER, LH, 571113
5	551905	1	BRACKET-MTG, CAB, CENTER, RH, 571113
6	551903	1	BRACKET-MTG, CAB, REAR, OUTBOARD, LH, 571113
7	551906	1	BRACKET-MTG, CAB, REAR, OUTBOARD, RH, 571113
8	551907	2	BRACKET-MTG, CAB, REAR, INBOARD, LH/RH, 571113
9	106880	6	SCREW-SQUARE HEAD, 5/16-18 UNC
10	102680	14	NUT-SERR FLG, HEX, SST, 5/16-18 UNC
11	102592	6	WSHR, RUBBER, .354 ID X 1.00 OD X .75 THK
12	106962	12	WSHR, FL, 3/8", .438 ID X 1.00 OD X .083" THK, BZP
13	106995	24	NUT, SERR FLG, HEX, 3/8-16 UNC, BZP
14	106960	6	STUD, -DBL ENDED, STL, 3/8-16 X 4.50", BZP
15	106963	6	BOLT, 3/8-16X1.00, BZP
16	108882	2	WSHR, FL, .59 ID X 1.06 OD X .19 THK, ZP
17	551571	2	BRKT, 90 DEGREE, 3 HOLES
18	106997	2	SCREW, HHC, 5/16-18X1.00, BZP
19	106996	2	NUT-SERR FLG, 5/16-18, BZP
20	106998	2	WSHR-FL,SST,5/16",BZP



1200 E. Birch St.

Brandon, SD 57005

REV B 21MAY14

REV A 04JAN11

551911 SHEET 2 OF 4 21OCT10

GM EXTENDED CAB

SERVICE PARTS LIST

MODEL NO. -571113

NOTE:

THE MOUNTING PATTERNS MAY NOT BE EXACTLY AS SHOWN. HOWEVER THERE WILL BE ENOUGH FASTENERS TO MAKE THE APPLICATION.

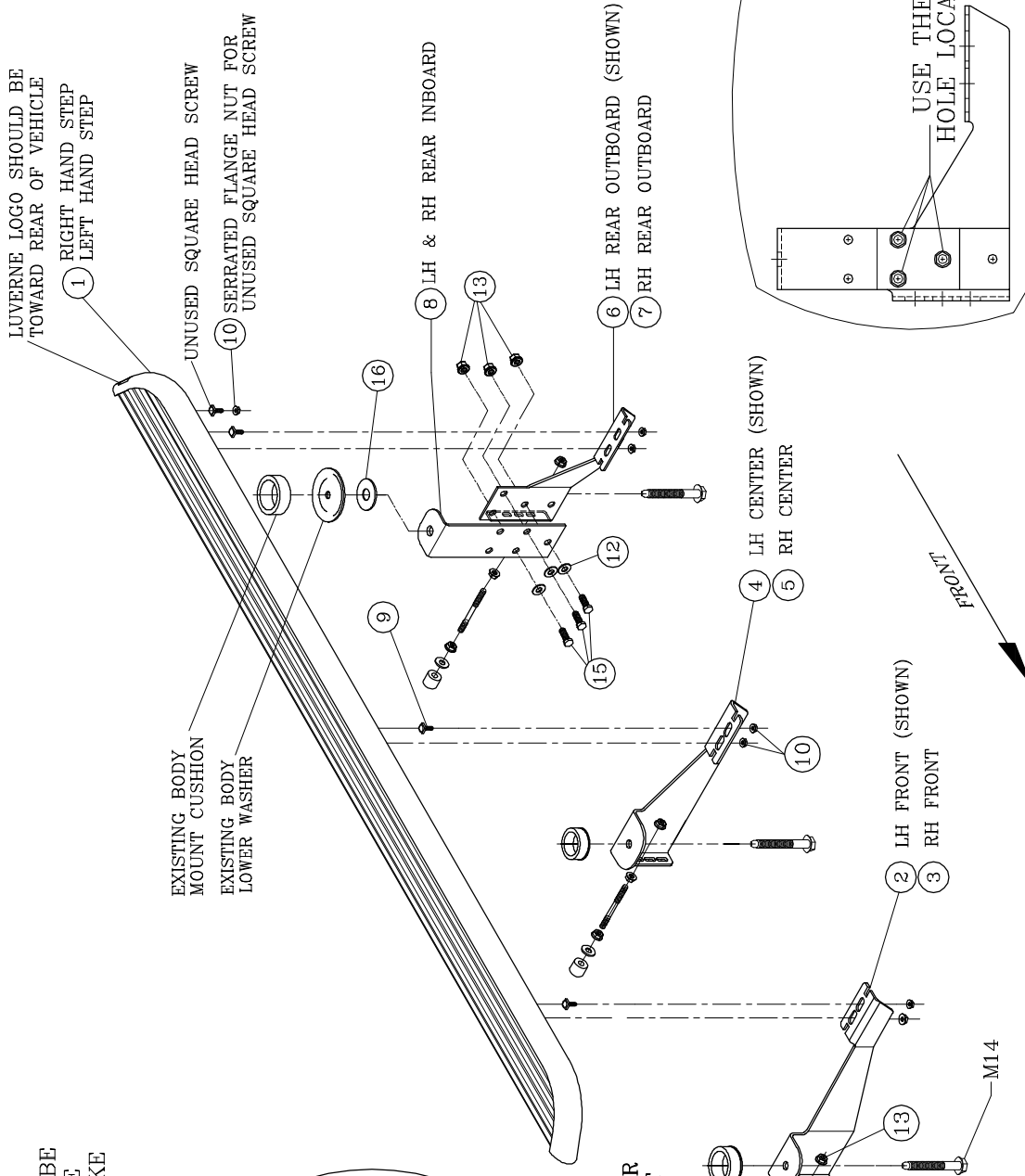
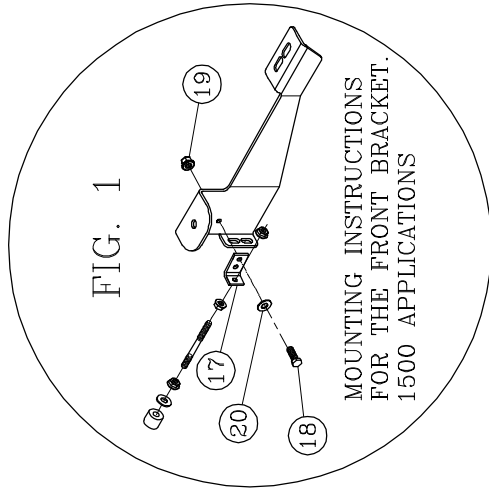

FIG. 2

EXISTING BODY MOUNT BOLTS TORQUE PER INSTRUCTION

LEFT (DRIVER) SIDE SHOWN
- RIGHT (PASSENGER) SIDE OPPOSITE-
REV B 21MAY14
REV A 04JAN11
551911 SHEET 3 OF 4 21OCT10



1288 E. 2nd St. Grand Rapids, MI 49505

GM CREW CAB

SERVICE PARTS LIST

MODEL NO. -571113

NOTE:
THE MOUNTING PATTERNS MAY NOT BE EXACTLY AS SHOWN. HOWEVER THERE WILL BE ENOUGH FASTENERS TO MAKE THE APPLICATION.

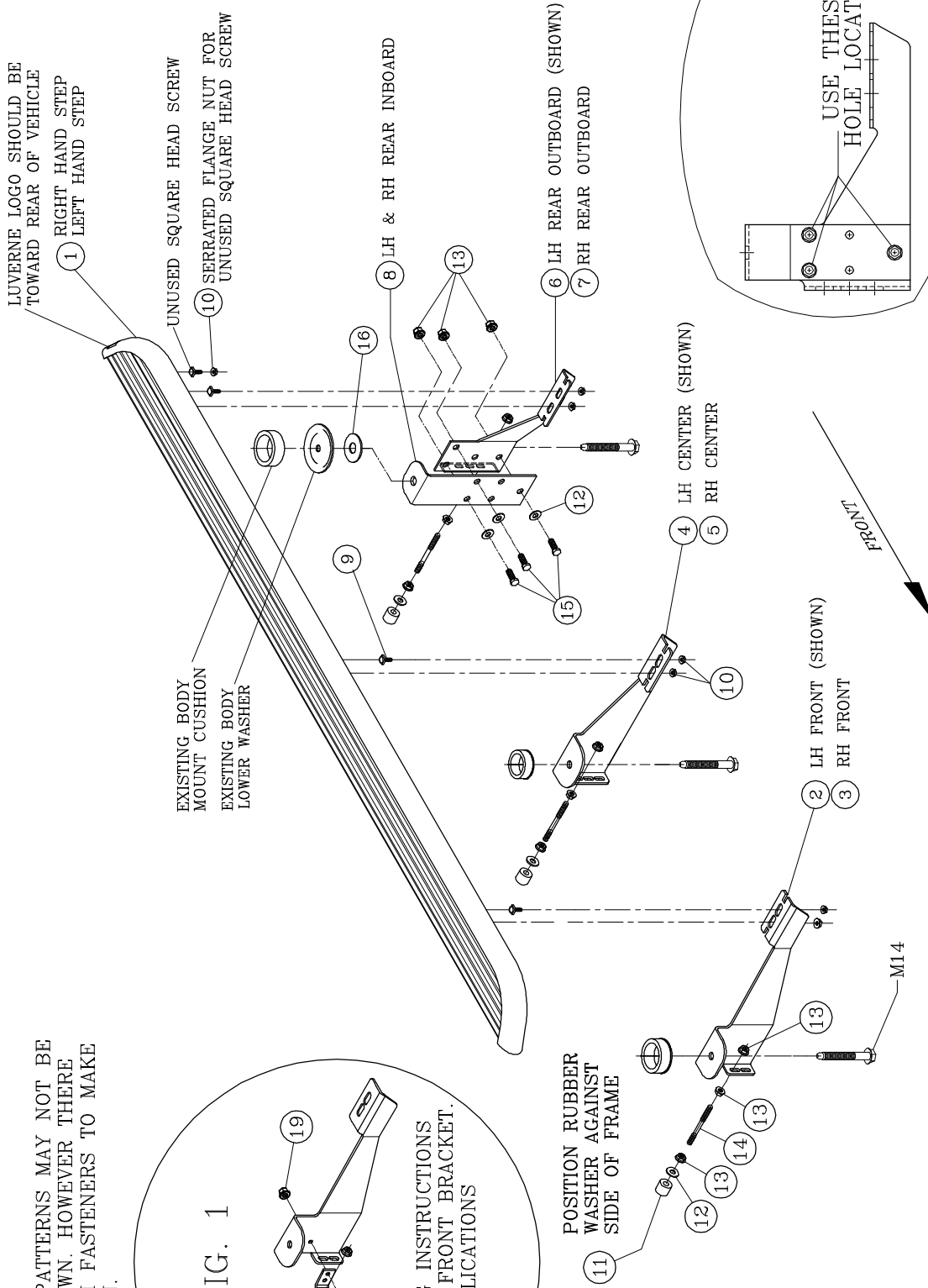
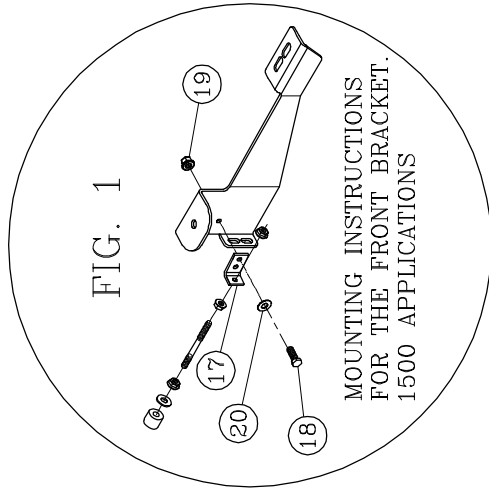

EXISTING BODY MOUNT BOLTS TORQUE PER INSTRUCTION

LEFT (DRIVER) SIDE SHOWN
-RIGHT (PASSENGER) SIDE OPPOSITE-

FIG. 3

REV B 21MAY14
REV A 04JAN11

551911 SHEET 4 OF 4 21OCT10



1288 E. 2nd St.
Grand Rapids, MI 49505