

INSTALLATION INSTRUCTIONS AND PARTS LIST

MODEL: 583098, 583102, 583108, 583114, 583125, 584098, 584102, 584114, 584125 O-MEGA II 6" OVAL
STEPS
UNIVERSAL APPLICATION

1. READ INSTRUCTIONS COMPLETELY AND CHECK TO MAKE SURE THAT ALL REQUIRED PARTS (LISTED ON THE SERVICE PARTS LIST) ARE ON HAND BEFORE STARTING THE INSTALLATION.
2. FOLLOW THE INSTRUCTIONS INCLUDED WITH THE SPECIFIC BRACKET PACKAGE THAT YOU ARE USING, TO MOUNT THE BRACKETS TO YOUR VEHICLE.
3. BEFORE ATTACHING THE O-MEGA STEPS TO THE BRACKETS, PLACE THE STEP PADS (ITEM #2) ON TOP OF THE STEP PLATES. USE THE TABLE ON SHEET #2, AS A GUIDE TO POSITION THE STEP PAD FOR YOUR PARTICULAR VEHICLE. WHEN INSTALLING THE PADS ON THE STEPS, DRILL (5) 1/8" HOLE USING THE STEP PAD AS A GUIDE. ATTACH WITH (5) 8-18X1/2" TEK SCREWS (ITEM #6) PROVIDED. REPEAT FOR ALL STEP PADS. (NOTE: DUE TO THE SHORTNESS OF SOME BOXES, MOUNT THE BOX STEP PAD FIRST, APPROXIMATELY 1/2" FROM THE END CAP AND THEN MOUNT THE MIDDLE STEP PAD ACCORDINGLY.)
4. INSTALL THE REQUIRED NUMBER OF SQUARE HEAD BOLTS INTO THE DESIGNATED SLOTS IN THE BOTTOM OF THE STEP PLATES.
5. INSTALL THE END CAPS (ITEM #3) AS SHOWN IN *fig. 1*, TIGHTENING THE NUTS TO 5 LB FT.
6. POSITION THE O-MEGA STEP ON THE MOUNTING BRACKETS SO THAT THE SQUARE HEAD SCREWS (ITEM #4) ARE LOCATED IN THE SLOTS OF THE MOUNTING BRACKETS AND THE STEP IS CENTERED, FRONT TO REAR, ON THE VEHICLE. INSTALL 5/16" SERRATED FLANGE NUTS (ITEM #5) ON THE SQUARE HEAD SCREWS (ITEM #4) AND TIGHTEN TO 19 LB FT.

SERVICE PARTS LIST

ITEM	PART NO.	QTY	DESCRIPTION
1	553074	2	EXTRUSION-AL,95.0,OMEGA STP,SILVEER
1	553075	2	EXTRUSION-AL,99.0,OMEGA STP,SILVER
1	553076	2	EXTRUSION-AL,105.0,OMEGA STP,SILVER
1	553077	2	EXTRUSION-AL,111.0,OMEGA STP,SILVER
1	553078	2	EXTRUSION-AL,122.0,OMEGA STP,SILVER
1	553062	2	EXTRUSION-AL,95.0,OMEGA STP,BLACK
1	553063	2	EXTRUSION-AL,99.0,OMEGA STP,BLACK
1	553065	2	EXTRUSION-AL,111.0,OMEGA STP,BLACK
1	553066	2	EXTRUSION-AL,122.0,OMEGA STP,BLACK
2	107957	6	ALUM,STP-PAD,BLK,OMEGA-STEP
3	107956	4	CAP-END,PLSTC,2.95 X 6.70
4	106880	28	SCREW-SQ HD,5/16-18 X 1,MAGNIGUARD
5	102680	28	NUT-SERR FLG,HX,SST,WX,5/16-18
6	107958	30	SCREW-PPH,TEK,#8-18 X 1/2",SST,BZP



STEP PAD LOCATION GUIDE



fig.1

VEHICLE MODEL	PAD A	PAD B
SILVERADO/SIERRA DOUBLE CAB	14-3/4	46-3/4
SILVERADO/SIERRA EXTENDED CAB	14-3/4	41-3/4
SILVERADO/SIERRA CREW CAB	14-3/4	54-1/4
CHEVROLET EXPRESS VAN & GMC SAVANA VAN	7-1/2	N/A
RAM QUAD CAB	10-1/2	46
RAM CREW CAB	10-1/2	48
RAM MEGA CAB	10-1/2	52-1/16
FORD F150 SUPER CAB	18-1/4	46-1/4
FORD F150 SUPER CREW CAB	18-1/4	56-1/2
FORD F150 SUPER CREW CAB	18-1/4	56-1/2
FORD SUPER DUTY SUPER CAB	6-7/8	39-1/16
FORD SUPER DUTY CREW CAB	6-7/8	52-7/8
FORD	7-1/2	N/A

NOTE: THE ABOVE PAD LOCATIONS ARE ONLY SUGGESTIONS AND MAY BE PLACED AT THE PURCHASERS DISCRETION.

INSTALLATION INSTRUCTIONS AND PARTS LIST
APPLICATION: MODEL 571338 W2W MEGA STEP BRACKETS ON:
2013-2015 RAM 3500 PICKUPS

1. READ INSTRUCTIONS COMPLETELY AND CHECK TO MAKE SURE THAT ALL REQUIRED PARTS (LISTED ON THE SERVICE PARTS LIST) ARE ON HAND BEFORE STARTING THE INSTALLATION.

2. ATTACH THE MOUNTING BRACKETS TO THE VEHICLE AS FOLLOWS:

RAM TRUCKS WITH THREADED INSERTS IN THE ROCKER PANEL.

- 2.1 PLACE THE DRIVERS SIDE FRONT BRACKET (ITEM #1) UP TO THE PINCHWELD SO THAT THE LOWER MOUNTING FLANGE IS TO THE OUTSIDE OF THE PINCHWELD, ALIGN THE TWO RECTANGULAR HOLES OF THE LOWER MOUNTING FLANGE OF (ITEM #1) WITH THE TWO OBOUNDED HOLES IN THE PINCHWELD, INSERT THE TWO 1/4-20 X 1" CARRIAGE BOLTS (ITEM #7) THROUGH THE LOWER MOUNTING FLANGE AND THEN THROUGH THE PINCHWELD, PLACE A 1/4" FLAT WASHER (ITEM #8), AND 1/4-20 FLANGE NUT (ITEM #9) ON TO THE CARRIAGE BOLTS, LEAVE FINGER TIGHT. **SEE FIGURES 1 & 2.**
- 2.2 INSERT AN M8 X 25mm SCREW (ITEM #10) WITH A 5/16" FLAT WASHER (ITEM #11) THROUGH THE SLOTS ON THE UPPER MOUNTING FLANGE, LEAVE FINGER TIGHT.
- 2.3 REPEAT STEPS 2.1 & 2.2 ON THE MIDDLE (ITEM #2) AND REAR (ITEM #3) BRACKETS.
- 2.4 FOR THE PASSENGER SIDE THE INSTALLATION IS A MIRROR IMAGE OF THE DRIVERS SIDE, USE (ITEM #2) FOR THE FRONT BRACKET, (ITEM #1) FOR THE MIDDLE BRACKET, & (ITEM #4) FOR THE REAR BRACKET.

RAM TRUCKS WITHOUT THREADED INSERTS IN THE ROCKER PANEL.

- 2.5 ON THE VERTICAL WALL OF THE ROCKER PANEL, INSTALL THE T-BOLT WELDMENT (ITEM #13) INTO THE LARGE OBOUNDED HOLE INSERTING THE NUT END FIRST, LEAVING THE THREADED STUD STICKING OUT OF THE OBOUNDED HOLE. **BE CAREFULL NOT TO DROP THE T-BOLT INSIDE OF THE ROCKER PANEL.** ATTACH THE FLAT PLASTIC BOLT RETAINER (ITEM #14) TO THE THREADED STUD OF THE T-BOLT. (THIS IS TO KEEP THE T-BOLT FROM FALLING INTO THE ROCKER PANEL.)
- 2.6 PLACE THE DRIVERS SIDE FRONT BRACKET (ITEM #1) UP TO THE PINCHWELD SO THAT THE LOWER MOUNTING FLANGE IS TO THE OUTSIDE OF THE PINCHWELD, ALIGN THE TWO RECTANGULAR HOLES OF THE LOWER MOUNTING FLANGE OF (ITEM #1) WITH THE TWO OBOUNDED HOLES IN THE PINCHWELD, INSERT THE TWO 1/4-20 X 1" CARRIAGE BOLTS (ITEM #7) THROUGH THE LOWER MOUNTING FLANGE AND THEN THROUGH THE PINCHWELD, PLACE A 1/4" FLAT WASHER (ITEM #8), AND 1/4-20 FLANGE NUT (ITEM #9) ON TO THE CARRIAGE BOLTS, LEAVE FINGER TIGHT. **SEE FIGURES 3 & 4.**
- 2.7 PLACE A FLAT WASHER (ITEM #10), AND AN M8 FLANGE NUT (ITEM #12), ON THE THREADED STUD OF THE T-BOLT (ITEM #11) LEAVE FINGER TIGHT.
- 2.8 ROTATE THE T-BOLT SO THAT THE THREADED NUT IS VISIBLE THROUGH THE SLOTTED HOLE IN THE UPPER MOUNTING FLANGE, INSERT AN M8 X 25mm SCREW (ITEM #10) WITH A 5/16" FLAT WASHER (ITEM #11), LEAVE FINGER TIGHT.
- 2.9 REPEAT STEPS 2.5 THRU 2.8 ON THE MIDDLE (ITEM #2) AND REAR (ITEM #3) BRACKETS.
- 2.10 FOR THE PASSENGER SIDE THE INSTALLATION IS A MIRROR IMAGE OF THE DRIVERS SIDE, USE (ITEM #2) FOR THE FRONT BRACKET, (ITEM #1) FOR THE MIDDLE BRACKET, & (ITEM #4) FOR THE REAR BRACKET.

NOTE: 2009 TO 2012 TRUCKS DO NOT HAVE THE OBOUNDED HOLES IN THE PINCH WELD, THEY WILL REQUIRE DRILLING (2) 5/16" HOLES FOR EACH BRACKET, TO GET THE PROPER LOCATION FOR DRILLING FOLLOW STEP 2.5, AND THEN SKIP TO STEP 2.7 & 2.8, WITH THE BRACKET IN PLACE, NOW MARK THE PINCHWELD FOR DRILLING.



3. ATTACH THE MOUNTING BRACKETS TO THE SHACKLE MOUNT OF THE VEHICLE AS FOLLOWS.
 - 3.1. ATTACH THE UPPER MOUNTING BRACKET (ITEM #6) TO THE SIDE OF THE LEAF SPRING SHACKLE BY LOOSENING THE BOLT THAT FASTENS THE LEAF SPRING TO THE VEHICLE. SLIDE THE UPPER MOUNTING BRACKET (ITEM #6) BETWEEN THE BOLT HEAD AND THE FRAME BRACKET, THEN PLACE A 3/8 BOLT AND WASHER (ITEM #15, 17) THROUGH THE HOLE IN THE UPPER MOUNTING BRACKET (ITEM #6) AND FRAME BRACKET THEN FASTEN WITH A 3/8" SERRATED FLANGE NUT (ITEM #16). TIGHTEN THE LEAF SPRING BOLT MAKING SURE THAT THE UPPER MOUNTING BRACKET (ITEM #6) IS LEVEL.
 - 3.2. FASTEN THE LOWER BRACKET (ITEM #5) TO THE UPPER BRACKET (ITEM #6) USING A 3/8" BOLT, WASHER, AND FLANGE NUT (ITEMS #15, 16, 17) USING THE TWO LOWER HOLES IN THE UPPER BRACKET MAKING SURE THAT IT SITS LEVEL TO THE FRONT BRACKETS.
4. INSTALL THE STEP PLATES, AND ADJUST BRACKETS, AND BOARDS BEFORE TIGHTENING ALL THE FASTENERS.

SERVICE PARTS LIST

ITEM	PART NO.	QTY	DESCRIPTION
1	553006	2	BRKT-MTG, WLDMNT, FRONT LH, MID RH. 571632
2	553007	2	BRKT-MTG, WLDMNT, FRONT RH, MID LH. 571632
3	553008	1	BRKT-MTG, WLDMNT, REAR LH, 571632
4	553009	1	BRKT-MTG, WLDMNT, REAR RH, 571632
5	551721	2	BRKT-MTG, MS, W2W, LH/RH, LOWER
6	551809	2	BRKT-MTG, MS, W2W, LH/RH, UPPER
7	101320	12	BLT-CRG, 1/4-20 X 1.00", SST, BLK, EM6219
8	101370	12	WSHR-FL, SST, .281 X .625 X .065
9	102366	12	NUT-FLG, HEX, 1/4-20, SST
10	102549	12	SCR-HEX HD, M8 X 1.25 X 25mm, ZP
11	100034	12	WSHR-FL, 5/16, ZP
12	105859	6	NUT HEX-FLG, M8 X 1.25, ZP
13	553012	6	T-BOLT WELDMNT, ZP, 571632
14	101572	6	BOLT RETAINER-PLASTIC, 8mm
15	100062	6	WSHR, FLAT, 3/8", .438 ID X 1.00 OD X .083" THK
16	100181	6	NUT, SERR FLG, HEX, 3/8-16 UNC, ZP
17	100040	6	SCR-HEX HD, 3/8-16 X 1.0" UNC, ZP

SERVICE PARTS LIST
 BRACKET NO. - 571338

INSTALLATION ON ROCKER
 PANELS WITH THREADED
 INSERTS

Fig. 1

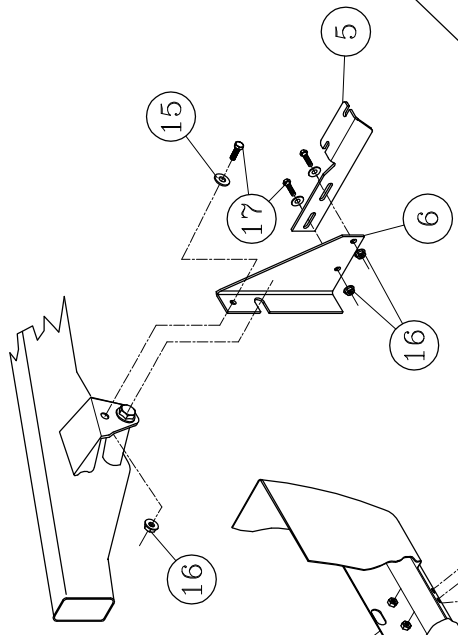
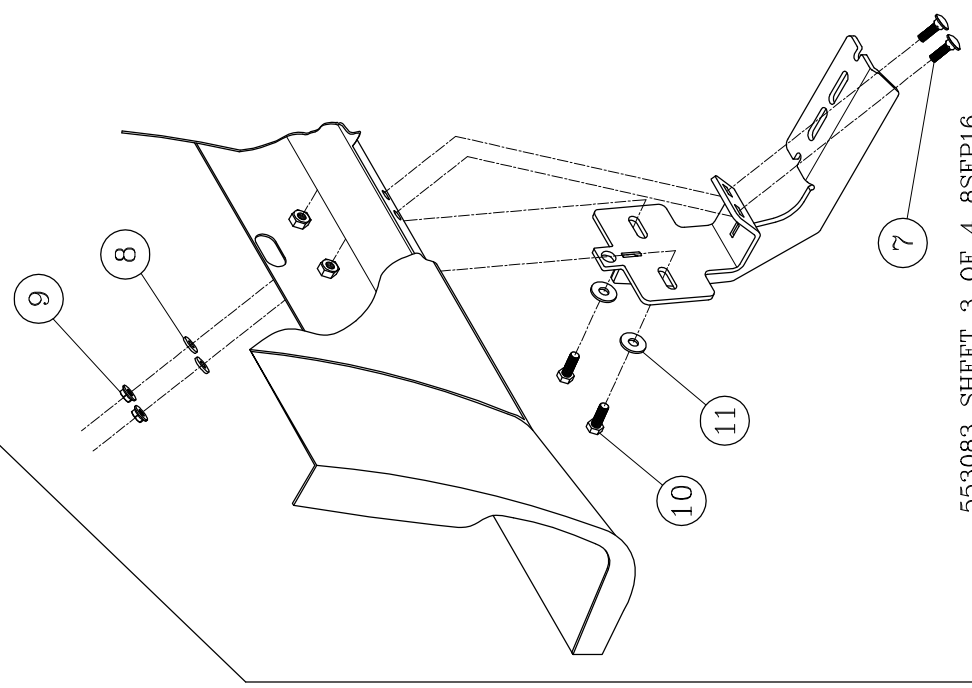

Fig. 2



LEFT (DRIVER) SIDE SHOWN
 -RIGHT (PASSENGER) SIDE OPPOSITE-



SERVICE PARTS LIST

BRACKET NO. - 571338

Fig. 3

INSTALLATION ON ROCKER
PANELS WITHOUT
THREADED INSERTS

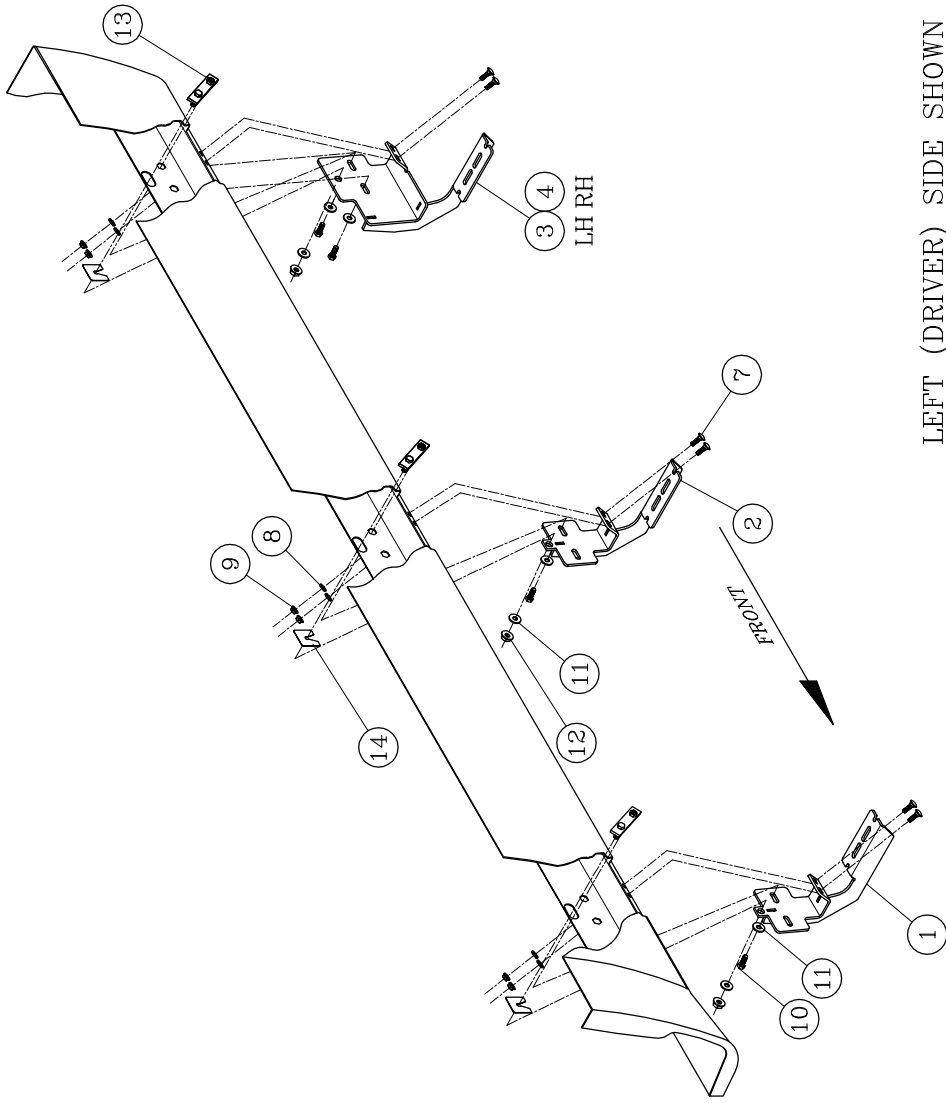

LEFT (DRIVER) SIDE SHOWN
-RIGHT (PASSENGER) SIDE OPPOSITE-

Fig. 4

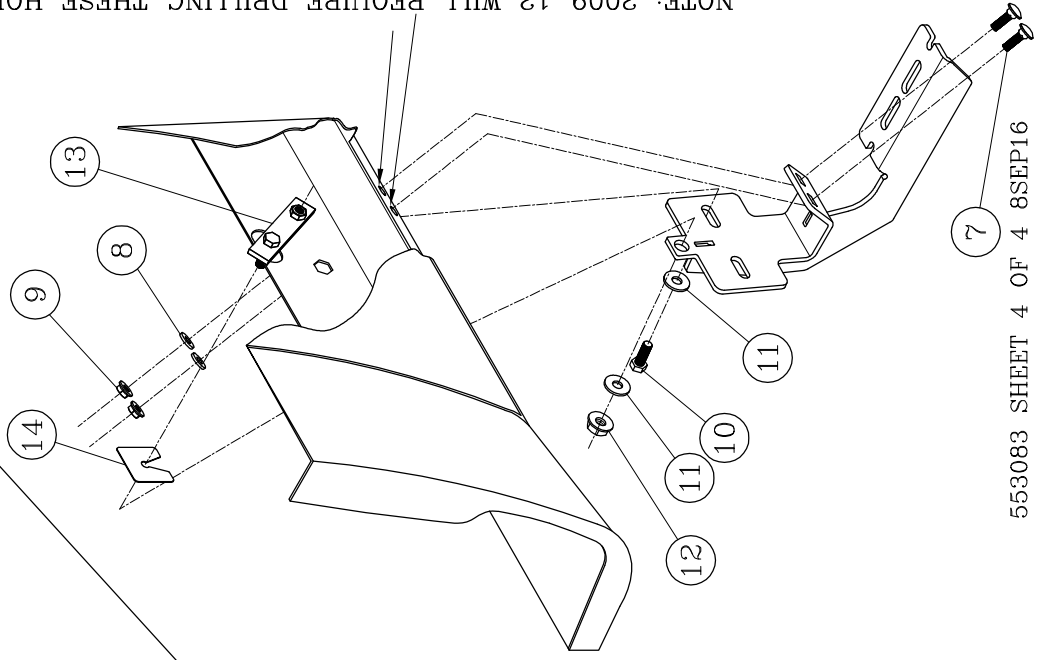

NOTE: 2009-12 WILL REQUIRE DRILLING THESE HOLES IN THE PINCHWELD.