



AUTOMOTIVE PRODUCTS,

INSTALLATION INSTRUCTIONS

6" PREMIER AND 4" OVAL TUBE MOUNT KIT

APPLICATION:

2006-2010 Ford Explorer/Mountaineer

2007-2010 Ford Explorer Sport Trac

PART NUMBER:

22-1575

ITEM	QUANTITY	DESCRIPTION	TOOLS NEEDED
1,2	2	STEP BAR, PASSENGER (1) AND DRIVER (2) (SOLD SEPERATELY)	3/4" DEEP WELL SOCKET
3	2	MOUNT ASSEMBLY PASSENGER	3/4" SOCKET
4	2	MOUNT ASSEMBLY DRIVER	9/16" SOCKET
5	1	1/2-13 X 1.50" BOLT PLATE ASSEMBLY (FRONT PASSENGER SIDE)	7/16" SOCKET
6	1	BOLT PLATE (REAR PASSENGER SIDE)	3/4" WRENCH
7	1	1/2-13 X 3.00" BOLT PLATE ASSEMBLY (FRONT DRIVE SIDE)	RATCHET
8	1	1/2-13 X 6.00" HEX HEAD BOLT	TORQUE WRENCH
9	3	1/2" FLAT WASHER	
10	5	1/2" LOCK WASHER	
11	5	1/2-13 HEX NUT	
12	1	3/8-16 X 2.00" HEX HEAD BOLT	
13	1	3/8" FLAT WASHER	
14	1	3/8" LOCK WASHER	
15	1	3/8-16 HEX NUT	
16	4	MOUNT ADAPTER PLATE (INCLUDED WITH STEP BARS)	
17	16	M6 LOCK NUT (INCLUDED WITH STEP BARS)	
18	16	M6 FLAT WASHER (INCLUDED WITH STEP BARS)	
19	3	SPACER WASHER	
20	2	SQUARE PLASTIC WASHER	
21	1	ROUND PLASTIC WASHER	
22	4	ROUND PLASTIC WASHER	
23	4	6 INCH ADAPTER PLATE (INCLUDED WITH STEP BARS)	

ANTI-SEIZE LUBRICANT MUST BE USED ON ALL STAINLESS STEEL FASTENERS TO PREVENT THREAD DAMAGE AND GALLING

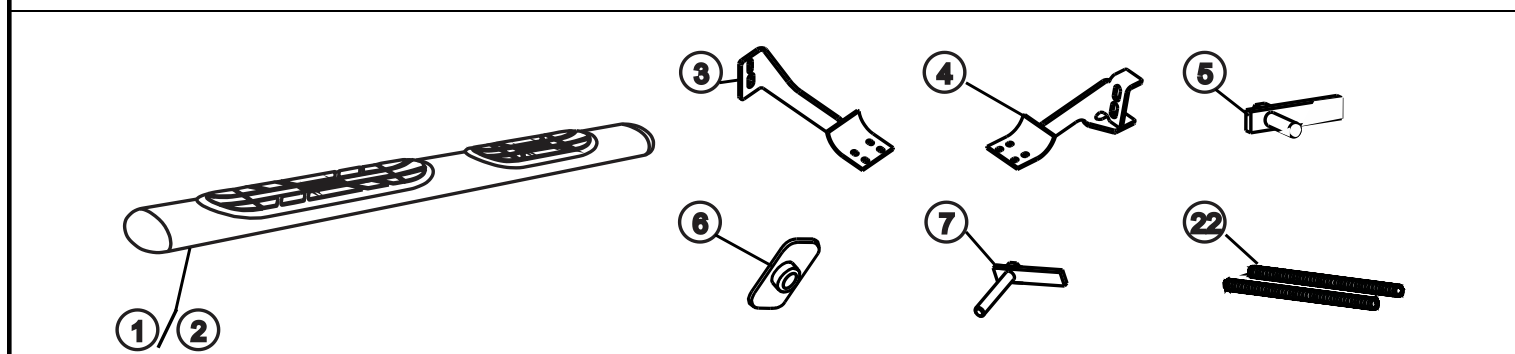

Westin Automotive Products, Inc.
320 W. Covina Blvd
San Dimas, Ca. 91773

PROCEDURE

1. Remove contents from box, verify if all parts listed are present and free from damage.
Carefully read and understand all instructions before attempting installation.
Failure to identify damage before installation could lead to a rejection of any claim.
2. Determine passenger and driver brackets.
3. Locate the rectangular hole along the side of the frame behind the front tire on the drivers side.
4. Attach square plastic washer to the 1/2-13 x 3.00" bolt plate assembly. Insert bolt plate into rectangular hole as shown. See **FIGURES 1 & 4**. Secure bolt plate to vehicle frame using the spacer washer, 1/2" lock washer, and 1/2-13 hex nut. Torque to 65 FT.LBS.
5. Install protective tubing over the two brake lines above and below the bolt plate. See **FIGURE 5**. Install front driver side bracket over the bolt and secure with 1/2" flat washer, lock washer, and hex nut as shown. See **FIGURES 4 & 5**. Leave loose. **NOTE:** Make sure brake lines are not under contact points of bracket and spacer washer.
6. Locate the round hole along the side of the frame in front of the rear tire on the drivers side.
7. Attach the large spacer washer to the 1/2-13 x 6.00" hex head bolt. Insert bolt through hole on backside of frame. Place another spacer washer on the front side of the frame. Center bolt and spacer washers and secure with 1/2" lock washer and hex nut. Torque to 65 FT.LBS. See **FIGURES 4 & 6**
8. Install protective tubing over the two brake lines above and below the bolt. See **FIGURE 6**. **NOTE:** Make sure brake lines are not under contact points of the bracket and spacer washer. Install driver side rear bracket over bolt using 1/2" fasteners as shown. Leave loose. See **FIGURES 4 & 6**.
9. Locate the rectangular hole along the side of the frame behind the front tire on the passenger side.
10. Attach square plastic washer to the 1/2-13 x 1.50" bolt plate assembly. Insert bolt plate into rectangular hole as shown. See **FIGURES 3 & 7**. Install passenger side front bracket over the bolt and secure with 1/2" flat washer, lock washer, and hex nut as shown. Leave loose.
11. Locate the round hole along the side of the frame in front of the rear tire on the passenger side.
12. Thread bolt plate onto 3/8-16 x 2.00" bolt and torque to 30 FT.LBS. See **FIGURE 8**. Attach the round plastic washer to the 3/8" bolt plate assembly. Insert bolt plate into round hole as shown. See **FIGURES 2 & 7**. Install passenger side rear bracket over the bolt and secure with 3/8" flat washer, lock washer, and hex nut as shown. Leave loose. See **FIGURE 7**.
13. Slide mount adapter plates on step bar as shown. Place step bar on saddle with long pad forward and end cap screw facing inward. Assemble with M6 hardware. See **FIGURES 9, 10, & 11**. Reference installation sheet, 75-0820, Oval Tube Mount Adapter Kit.
14. Make sure step bar and brackets are properly aligned with vehicle and tighten fasteners. Recommended torque values are 26 FT.LBS. for 3/8" fasteners, 7 FT.LBS. for 1/4" fasteners., and 64 FT.LBS. for 1/2" fasteners.

FIGURE 1 DRIVER SIDE FRONT

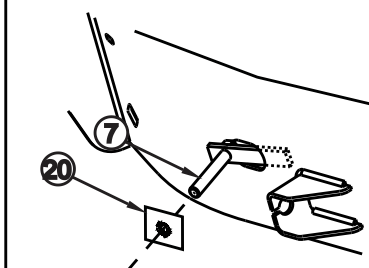

FIGURE 2 PASSENGER SIDE REAR

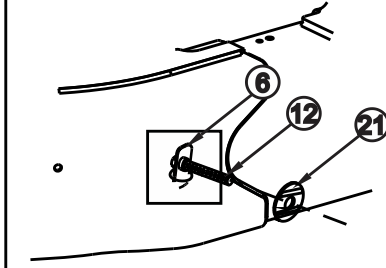
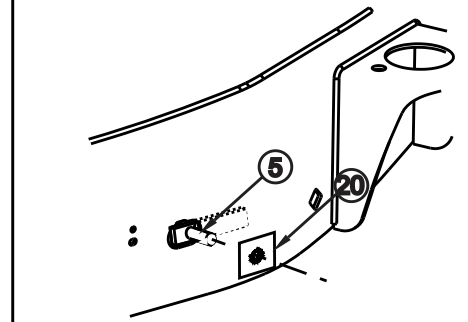

FIGURE 3 PASSENGER SIDE FRONT



Westin Automotive Products, Inc.
320 W. Covina Blvd
San Dimas, Ca. 91773

Thank you for choosing Westin products
for additional installation assistance please call
Customer Service (800) 793-7846
www.westinautomotive.com

FIGURE 4 DRIVER SIDE SHOWN

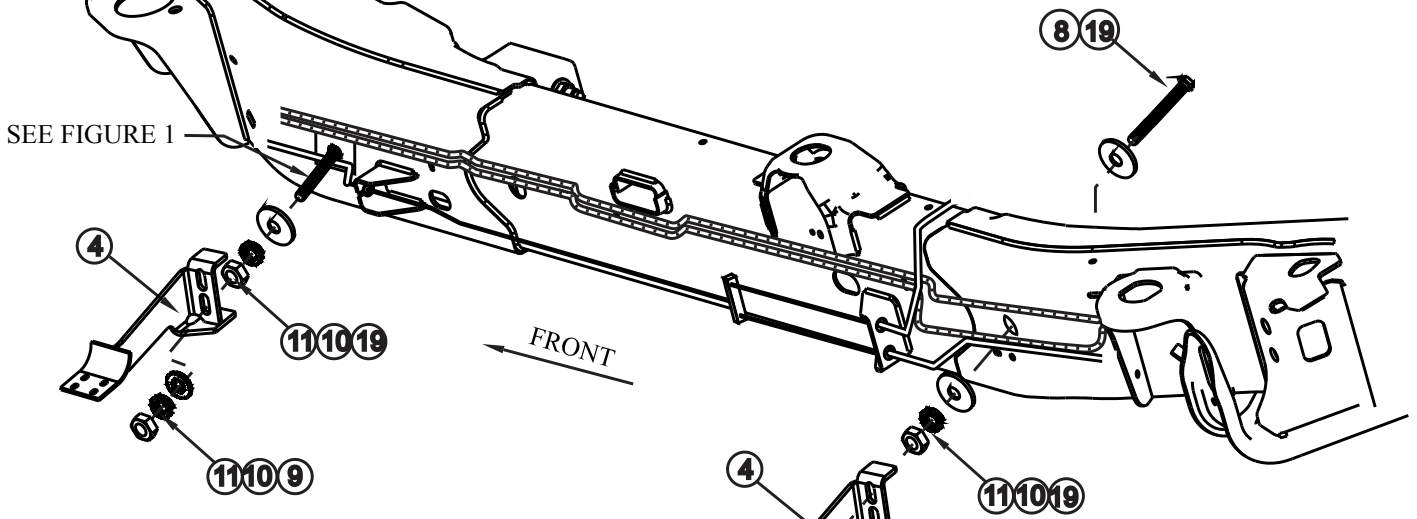

FIGURE 5 FRONT DRIVER

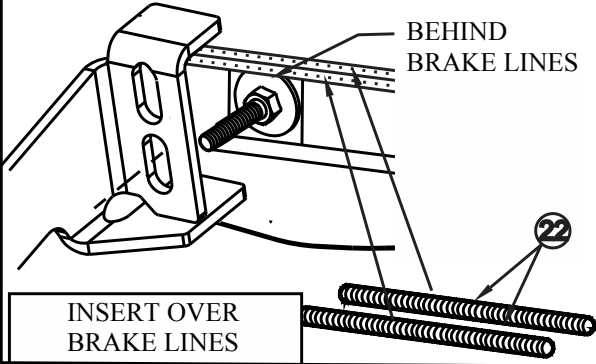

FIGURE 6 REAR DRIVER

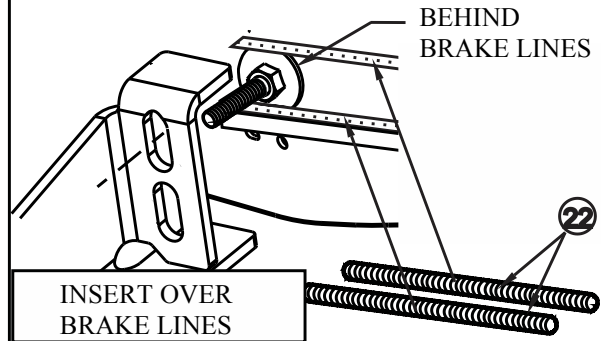

FIGURE 7 PASSENGER SIDE SHOWN

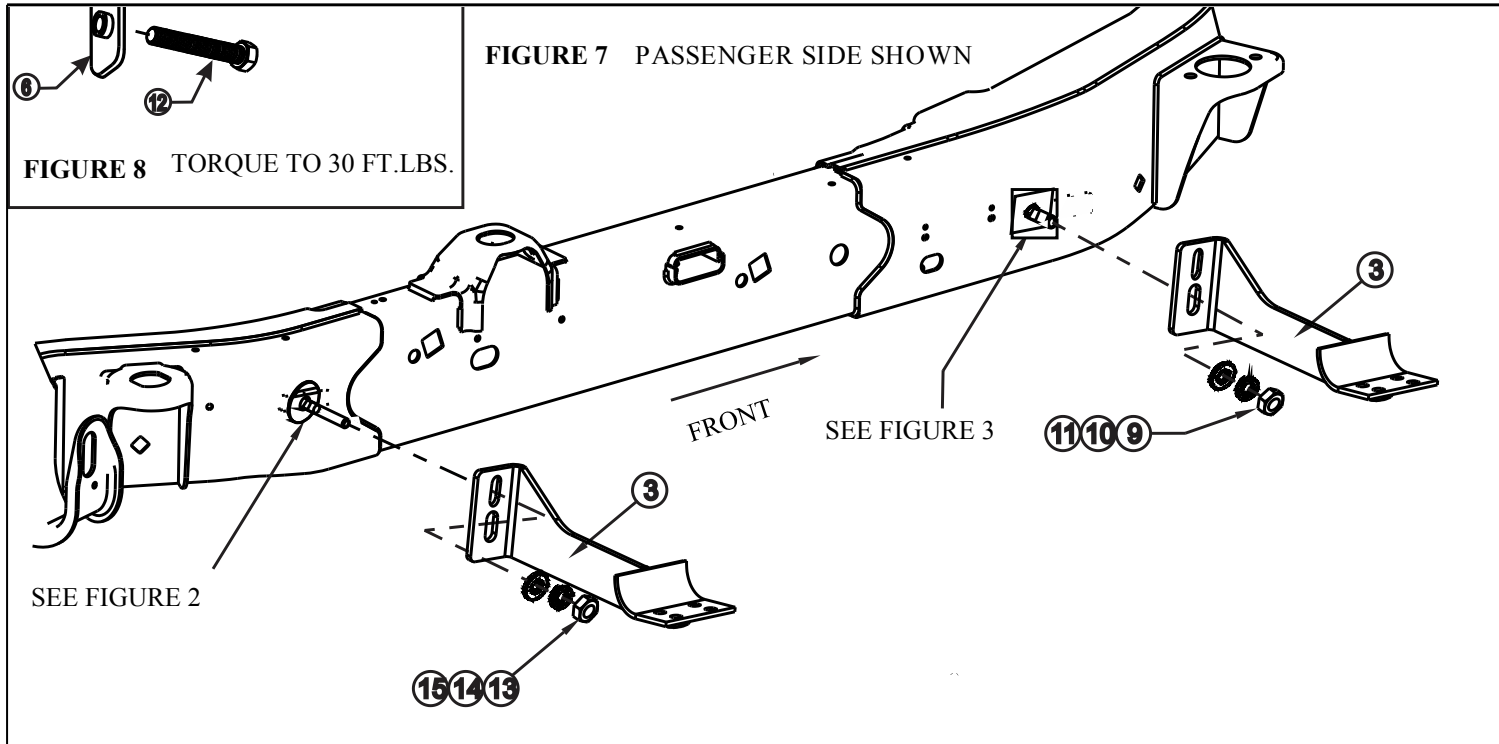
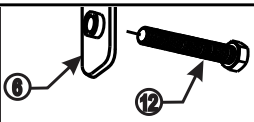
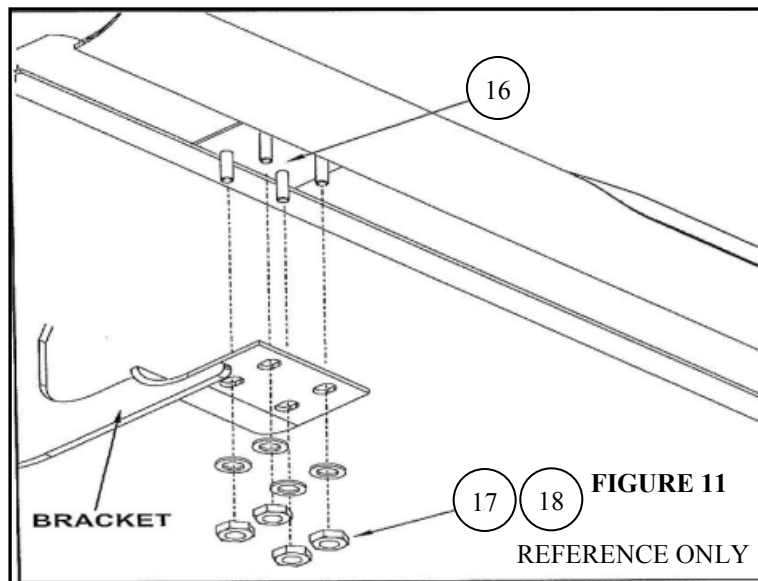
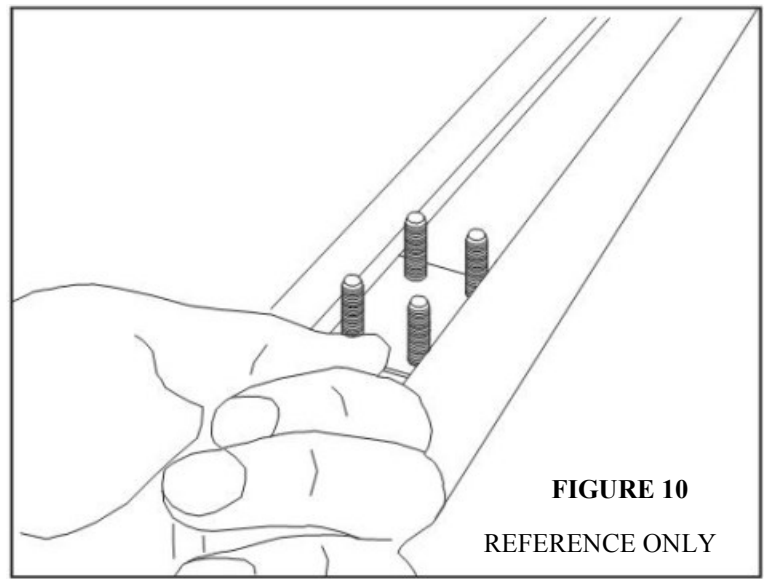
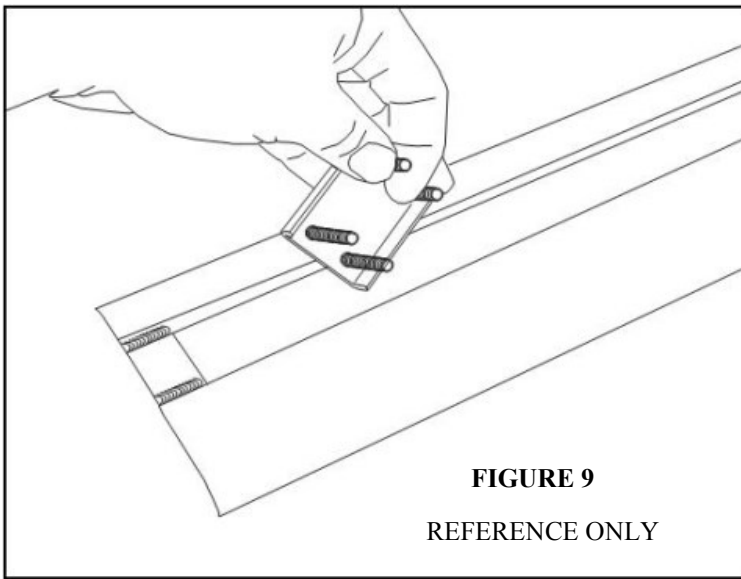

FIGURE 8 TORQUE TO 30 FT.LBS.



Westin Automotive Products, Inc.
 320 W. Covina Blvd
 San Dimas, Ca. 91773

Thank you for choosing Westin products
 for additional installation assistance please call
 Customer Service (800) 793-7846
 www.westinautomotive.com



CARE INSTRUCTIONS

- REGULAR WAXING IS RECOMMENDED. DO NOT USE ANY TYPE OF POLISH OR WAX THAT MAY CONTAIN ABRASIVES.
- STAINLESS STEEL PRODUCTS CAN BE CLEANED WITH MILD SOAP AND WATER. STAINLESS STEEL POLISH SHOULD BE USED TO POLISH SMALL SCRATCHES.
- GLOSS BLACK FINISHES SHOULD BE CLEANED WITH MILD SOAP AND WATER.



Westin Automotive Products, Inc.
320 W. Covina Blvd
San Dimas, Ca. 91773

Thank you for choosing Westin products
for additional installation assistance please call
Customer Service (800) 793-7846