



INSTALLATION INSTRUCTIONS

HDX DROP STEP

AUTOMOTIVE PRODUCTS,

APPLICATION:

2007-2016 Jeep Wrangler 2Dr - 4Dr

PART NUMBER:

56-13295, 56-13315

CONTENT			
ITEM	QUANTITY	DESCRIPTION	TOOLS NEEDED
1	2	STEP BAR ASSEMBLY	RATCHET
2*	2	CENTER MOUNT BRACKET, DRIVER AND PASSENGER	TORQUE WRENCH
3*	2	CENTER SUPPORT BRACKET, DRIVER AND PASSENGER	10MM SOCKET
4	2	FRONT MOUNT BRACKET, DRIVER AND PASSENGER	13MM SOCKET
5	2	FRONT SUPPORT BRACKET, DRIVER AND PASSENGER	13MM WRENCH
6	2	REAR MOUNT BRACKET, DRIVER AND PASSENGER	SOCKET EXT.
7	2	REAR SUPPORT BRACKET, DRIVER AND PASSENGER	ALLEN WRENCH
8	4 , 6*	M8 EXTRUDED U-NUT (BLUE DACROMET)	
9	8 , 12*	LONG M8 HEX HEAD CAP SCREW (YELLOW ZINC)	
10	16 , 24*	M8 SPLIT LOCK WASHER (YELLOW ZINC)	
11	4 , 6*	M8 HEX NUT (YELLOW ZINC)	
12	20 , 30*	M8 FLAT WASHER (YELLOW ZINC)	
13	8 , 12*	SHORT M8 HEX HEAD CAP SCREW (YELLOW ZINC)	
14	8 , 12*	M6 BUTTON HEAD CAP SCREW (S/S BLACK ZINC)	
15	8 , 12*	M6 FLAT WASHER (S/S BLACK ZINC)	
16	8 , 12*	M6 FLAT WASHER (YELLOW ZINC)	
17	8 , 12*	M6 LOCK WASHER (YELLOW ZINC)	
18	8 , 12*	M6 HEX NUT (YELLOW ZINC)	
*4 DOOR JEEP HAS MORE HARDWARE AND 4 DOOR JEEP HAS CENTER MOUNT/SUPPORT BRACKET			
ANTI-SEIZE LUBRICANT MUST BE USED ON ALL STAINLESS STEEL FASTENERS TO PREVENT THREAD DAMAGE AND GALLING			

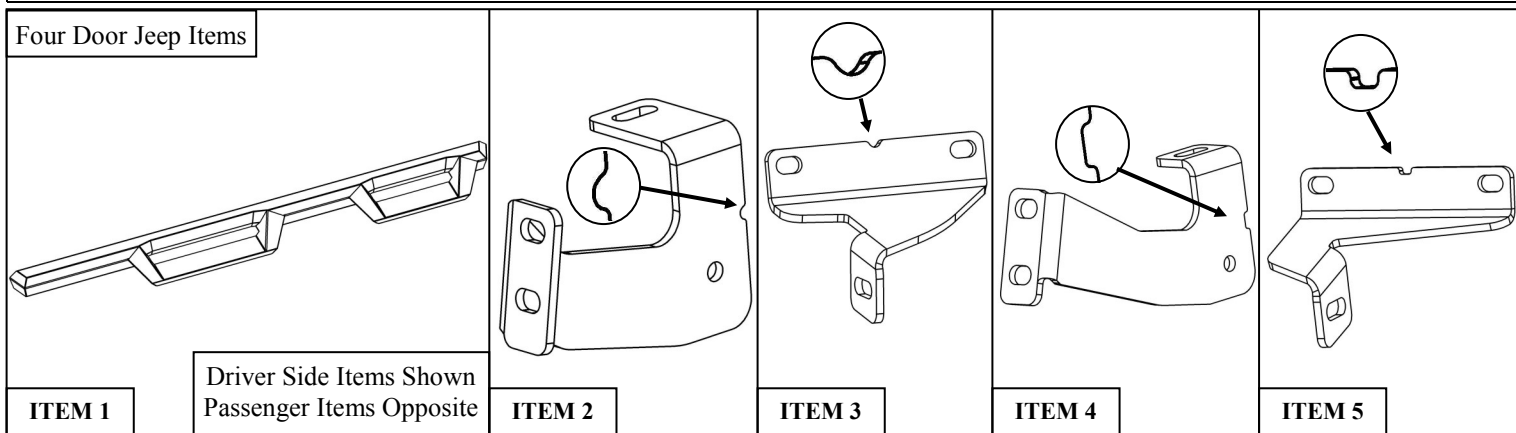

Westin Automotive Products, Inc.
320 W. Covina Blvd
San Dimas, Ca. 91773

Thank You for choosing Westin products
For Additional installation assistance please call
Customer service (800) 793-7846

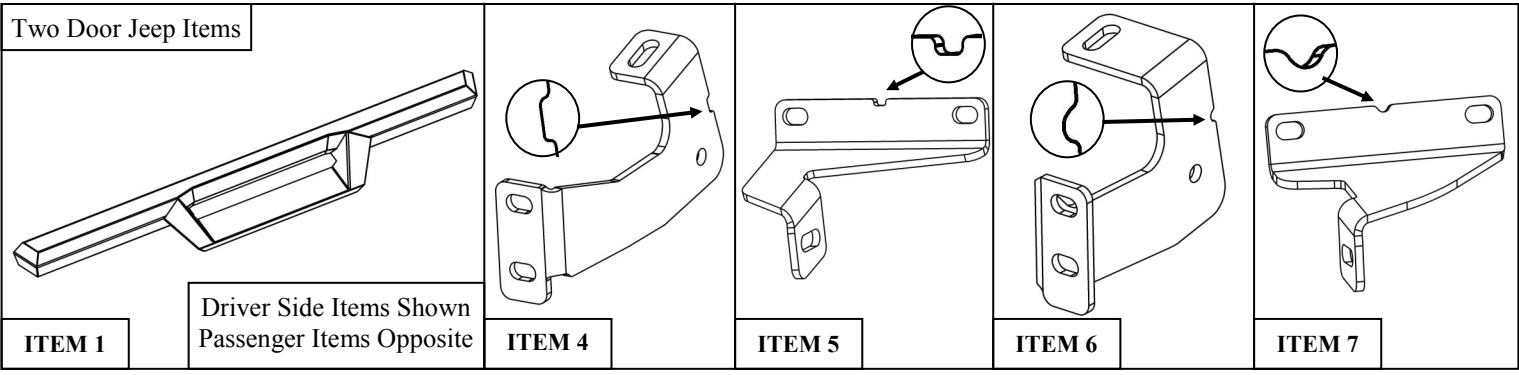
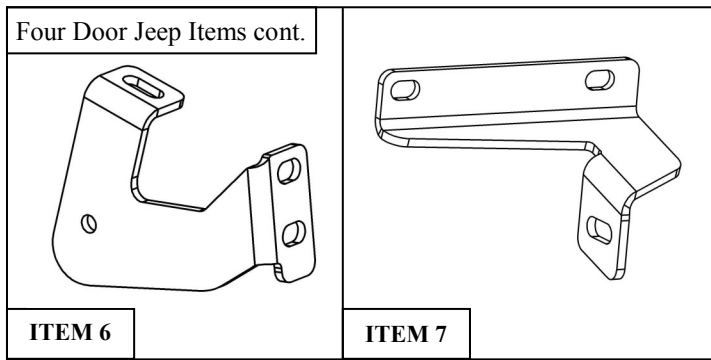

PROCEDURE

- Remove contents from box, verify if all parts listed are present and free from damage. Carefully read and understand all instructions before attempting installation.
Failure to identify damage before installation could lead to a rejection of any claim.
- Starting on the driver side, locate each mounting location. The 4 door Jeep will have three mounting locations on each side and the 2 door Jeep will have two mounting locations.
- Follow steps 2 - 4 for 4 door Jeeps:** Starting at the front mount location, locate (1) Front Mount Bracket (Item 4) and (1) Front Support Bracket (Item 5). Loosely secure brackets, using: (2) long M8 hex head cap screw, (1) M8 extruded u-nut, (2) M8 split lock washer, (1) M8 hex nut, (3) M8 flat washer, (2) M6 hex nut, (2) M6 button head cap screw, (2) M6 split lock washer, and (4) M6 flat washers. **See Figure 1. Note:** M8 extruded u-nut is only used if a threaded hole is not present (circled on **Figure 1**).
- For the center mounting location, locate (1) Center Mount Bracket (Item 2) and (1) Center Support Bracket (Item 3). Loosely secure brackets, using: (2) long M8 hex head cap screw, (1) M8 extruded u-nut, (2) M8 split lock washer, (1) M8 hex nut, (3) M8 flat washer, (2) M6 hex nut, (2) M6 button head cap screw, (2) M6 split lock washer, and (4) M6 flat washers. **Note:** M8 extruded u-nut is only used if a threaded hole is not present (circled), **See Figure 2.**

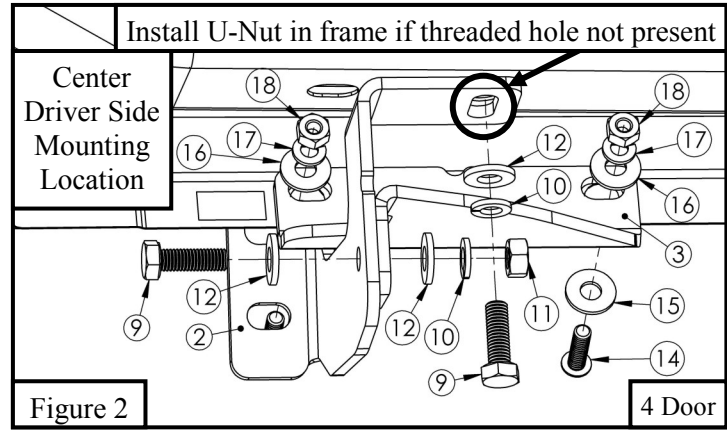
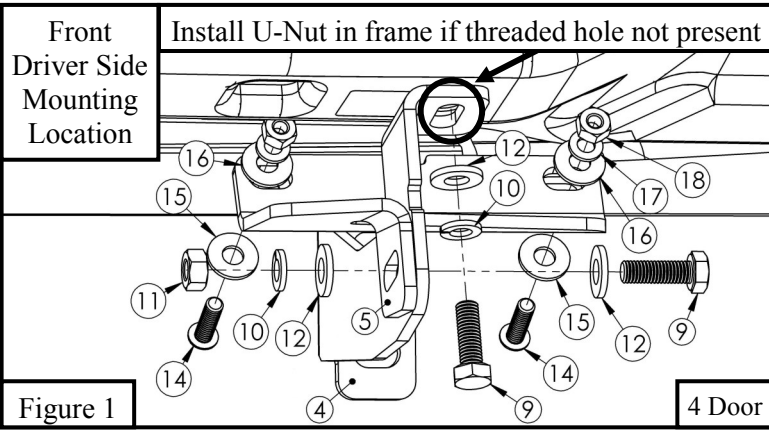

Westin Automotive Products, Inc.
320 W. Covina Blvd
San Dimas, Ca. 91773

Thank You for choosing Westin products
For Additional installation assistance please call
Customer service (800) 793-7846

4. For the rear mounting location, locate (1) Rear Mount Bracket (Item 6) and (1) Rear Support Bracket (Item 7). Loosely secure brackets, using: (2) long M8 hex head cap screw, (1) M8 extruded u-nut, (2) M8 split lock washer, (1) M8 hex nut, (3) M8 flat washer, (2) M6 hex nut, (2) M6 button head cap screw, (2) M6 split lock washer, and (4) M6 flat washers. **Refer to Figure 1**, Similar installation as front mounting bracket.
5. **Follow steps 5 - 6 for 2 door Jeeps:** Starting at the front mount location, locate (1) Front Mount Bracket (Item 4) and (1) Front Support Bracket (Item 5). Loosely secure brackets, using: (2) long M8 hex head cap screw, (1) M8 extruded u-nut, (2) M8 split lock washer, (1) M8 hex nut, (3) M8 flat washer, (2) M6 hex nut, (2) M6 button head cap screw, (2) M6 split lock washer, and (4) M6 flat washers. **See Figure 3. Note:** M8 extruded u-nut is only used if a threaded hole is not present (circled on **Figure 3**).
6. For the rear mounting location, locate (1) Rear Mount Bracket (Item 6) and (1) Rear Support Bracket (Item 7). Loosely secure brackets, using: (2) long M8 hex head cap screw, (1) M8 extruded u-nut, (2) M8 split lock washer, (1) M8 hex nut, (3) M8 flat washer, (2) M6 hex nut, (2) M6 button head cap screw, (2) M6 split lock washer, and (4) M6 flat washers. **See Figure 4. Note:** M8 extruded u-nut is only used if a threaded hole is not present (circled on **Figure 4**).
7. Locate (1) Step Bar Assembly and loosely secure it onto the previously installed brackets using the provided M8 hardware. **See Figure 5.**
8. Repeat steps 2 - 4 and 7 for passenger side on 4 door Jeeps and steps 5 - 7 for 2 door Jeeps. See **Figures 6 and 7** for bracket orientation.
9. Align step bar and brackets to desired positioning then torque and tighten all: M8 hardware to 20 ft-lbs and M6 to 12 ft-lbs.

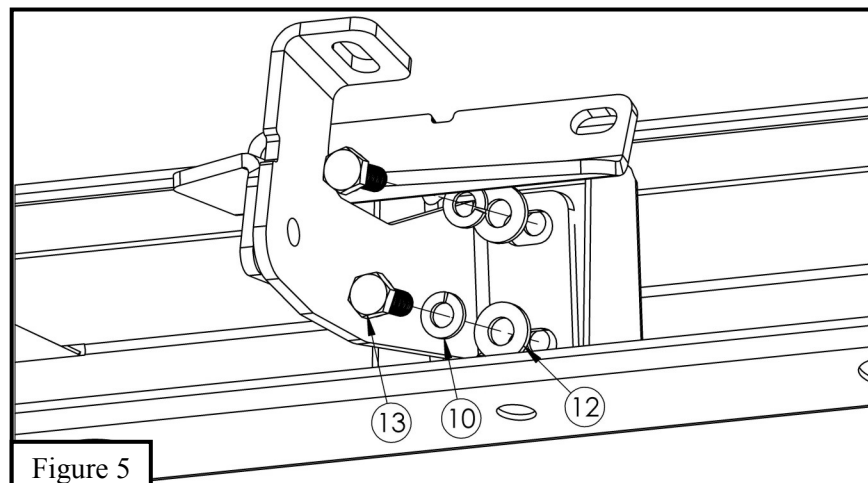
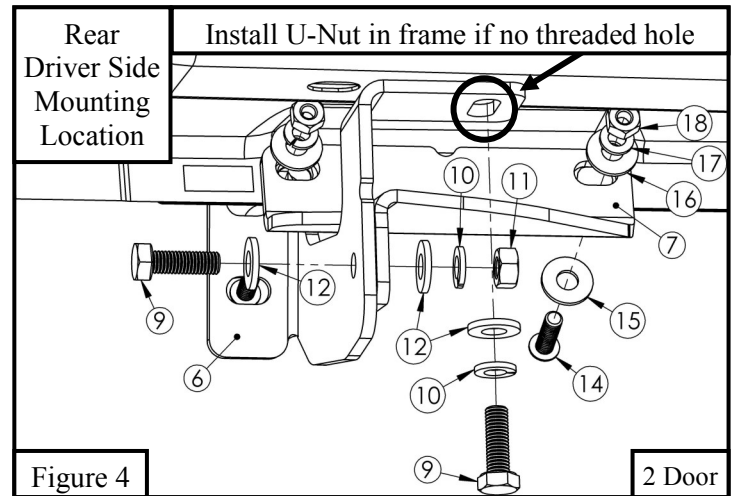
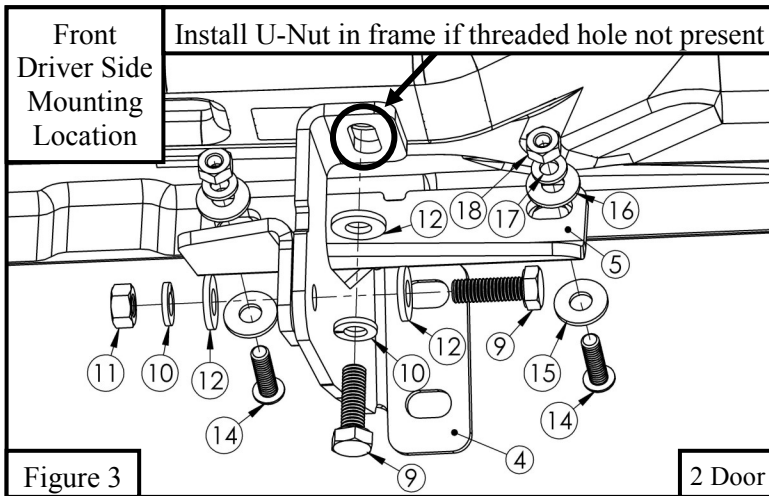

Westin Automotive Products, Inc.
320 W. Covina Blvd
San Dimas, Ca. 91773

Thank You for choosing Westin products
For Additional installation assistance please call
Customer service (800) 793-7846

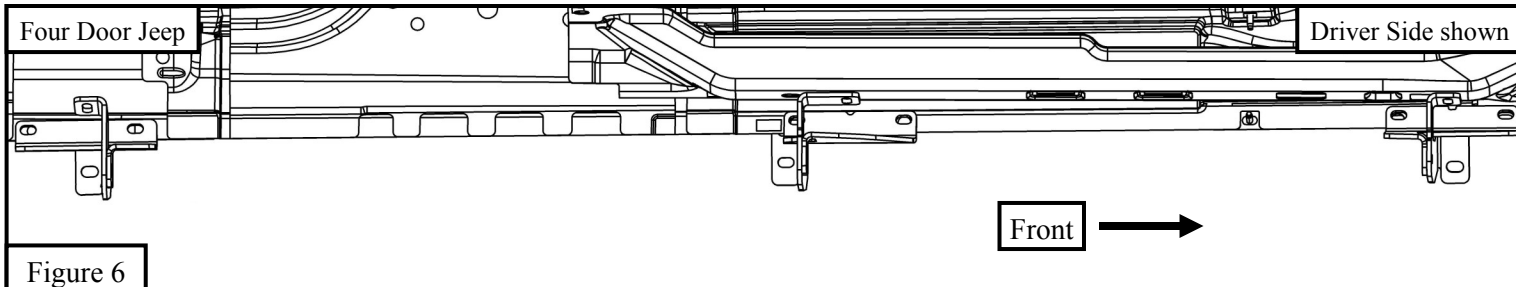

Figure 6

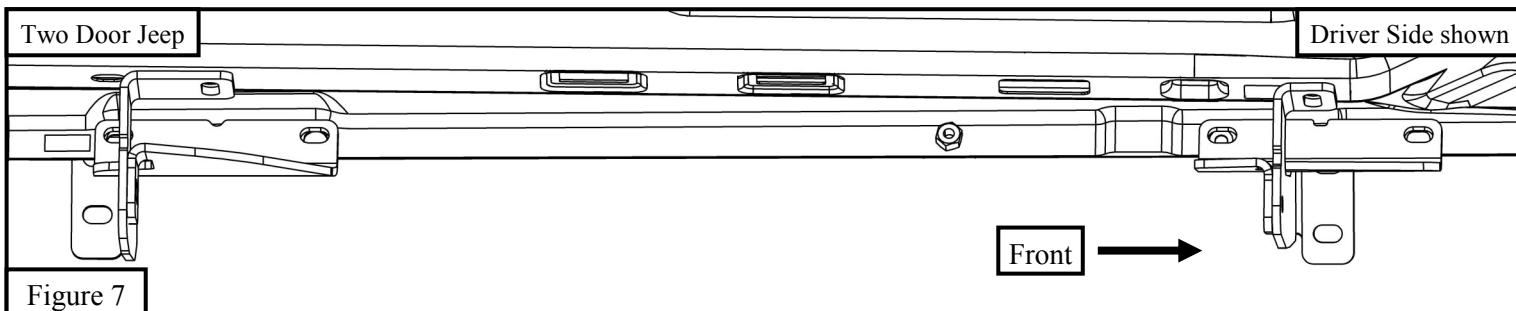

Figure 7



INSTALLATION COMPLETE



Care Instructions

- REGULAR WAXING IS RECOMMENDED. DO NOT USE ANY TYPE OF POLISH OR WAX THAT MAY CONTAIN ABRASIVES.
- STAINLESS STEEL PRODUCTS CAN BE CLEANED WITH MILD SOAP AND WATER. STAINLESS STEEL POLISH SHOULD BE USED TO POLISH SMALL SCRATCHES.
- GLOSS BLACK FINISHES SHOULD BE CLEANED WITH MILD SOAP AND WATER.



Westin Automotive Products, Inc.
320 W. Covina Blvd
San Dimas, Ca. 91773

Thank You for choosing Westin products
For Additional installation assistance please call
Customer service (800) 793-7846
www.westinautomotive.com

Westin

SIGNATURE OF QUALITY

AUTOMOTIVE PRODUCTS, INC.



WARNING



Failure to follow these instructions could lead to death, personal injury, and / or property damage.

FASTENERS:

All Westin supplied fasteners must be utilized and installed in accordance with the installation instructions and apply torque to the specifications as defined. **DOUBLE CHECK ALL FASTENERS BEFORE INITIAL USE, AND PERIODICALLY IN THE FUTURE TO ENSURE PROPER FUNCTION AND SAFETY.**

DRILLING:

Most Westin products do not require drilling for installation. If drilling is defined as required, use caution when drilling a vehicle. **FAILURE TO REVIEW AN AREA TO BE DRILLED MAY RESULT IN PERSONAL INJURY AND/OR INJURY TO OTHERS AS WELL AS VEHICLE DAMAGE.**

EYE PROTECTION:

ALWAYS WEAR SAFETY GLASSES OR GOGGLES DURING THE INSTALLATION PROCESS TO AVOID PERSONAL INJURY.

MAXIMUM TOWING/CARRYING CAPACITY:

The Westin Receiver Hitches will have a visible tow rating label affixed directly on the product. User should never exceed the vehicle manufacturers maximum tow and weight rating regardless of the capacity of the hitch. **FAILURE TO FOLLOW THESE GUIDELINES WILL VOID THE WESTIN WARRANTY AND MAY RESULT IN PERSONAL INJURY AND/OR INJURY TO OTHERS AS WELL AS VEHICLE DAMAGE.**

Westin
SIGNATURE OF QUALITY

Westin Automotive Products, Inc.
320 W. Covina Blvd
San Dimas, Ca. 91773