



SIGNATURE OF QUALITY

AUTOMOTIVE PRODUCTS, INC.

INSTRUCTIONS—INSTRUCCIONES—CONSIGNES

PROTRAXX-4 STEP BAR KIT
APPLICATION: 2007-2014 JEEP WRANGLER 2-DOOR
APP PART # 21-23310, 21-23315

ITEM	QUANTITY	DESCRIPTION	TOOLS NEEDED
1, 2	2	DRIVER (1) & PASSENGER SIDE (2) STEP BARS	16MM SOCKET
3,4	2	DRIVER (3) & PASSENGER SIDE (4) FRONT MOUNTING BRACKET (SQUARE RELIEF)	RATCHET
5,6	2	DRIVER (5) & PASSENGER SIDE (6) FRONT SUPPORT BRACKET (SQUARE RELIEF)	16MM WRENCH
7,8	2	DRIVER (7) & PASSENGER SIDE (8) REAR MOUNTING BRACKET (SEMI-ROUND RELIEF)	5MM HEX DRIVER/ ALLEN KEY
9,10	2	DRIVER (9) & PASSENGER SIDE (10) REAR SUPPORT BRACKET (SEMI-ROUND RELIEF)	13MM SOCKET
11	12	M8 HEX CAP SCREW (BLK ZINC OVER S.S.)	13MM WRENCH
12	20	M8 X 16MM OD FLAT WASHER (BLK ZINC OVER S.S.)	5/16" / 3/8" DRILL BIT
13	12	M8 SPLIT LOCK WASHER	POWER DRILL
14	8	M8 HEX NUT	
15	8	M10 HEX SOCKET BUTTON HEAD SCREW (BLK ZINC OVER S.S.)	
16	16	M10 X 20MM OD FLAT WASHER (BLK ZINC OVER S.S.)	
17	8	M10 INTERNAL TOOTHED LOCK WASHER (BLK ZINC OVER S.S.)	
18	4	M8 CLIP NUT	
19	4	M10 X 30MM HEX CAP SCREW	
20	4	M10 SPLIT LOCK WASHER	
21	4	M10 HEX NUT	

ANTI-SEIZE LUBRICANT MUST BE USED ON ALL STAINLESS STEEL FASTENERS TO PREVENT THREAD DAMAGE AND GALLING

CARE INSTRUCTIONS

- REGULAR WAXING IS RECOMMENDED. DO NOT USE ANY TYPE OF POLISH OR WAX THAT MAY CONTAIN ABRASIVES
- STAINLESS STEEL PRODUCTS CAN BE CLEANED WITH MILD SOAP AND WATER. STAINLESS STEEL POLISH SHOULD BE USED TO POLISH SMALL SCRATCHES.
- GLOSS BLACK FINISHES SHOULD BE CLEANED WITH MILD SOAP AND WATER



Westin Automotive Products, Inc.
320 Covina Blvd
San Dimas, Ca. 91773

Thank You for choosing Westin products
For Additional installation assistance please call
Customer service (800) 793-7846
www.westinautomotive.com

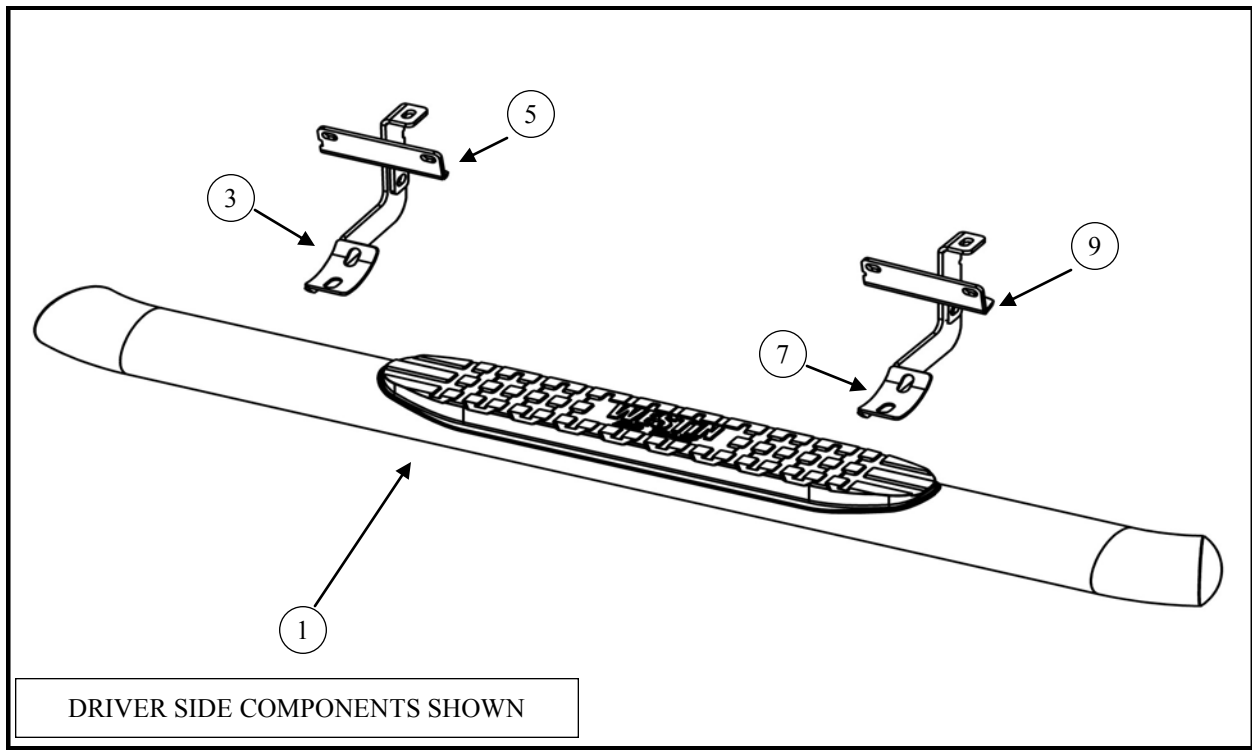

1. Remove contents from box, verify if all parts listed are present and free from damage. Carefully read and understand all instructions before attempting installation.

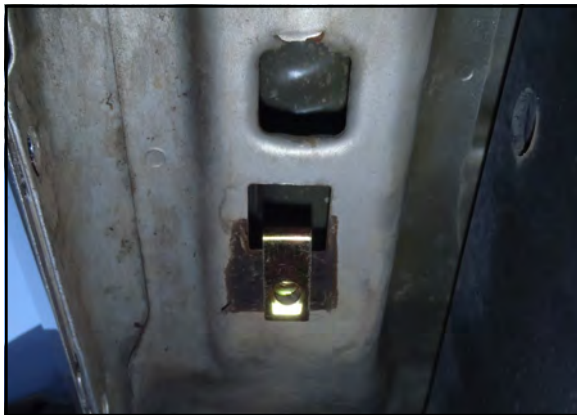

2. Starting at the front driver side mounting location. The bottom rocker mounting hole may be covered by black tape. After removal, insert an M8 clip nut through the square hole. Some vehicles may already be equipped with a threaded hole.



3. Attach the driver front mounting bracket to the vehicle underbody using (x1) M8 hex cap screw, (x1) M8 split lock washer, and (x1) M8 flat washer.
4. Attach the driver side front support bracket to the pinch weld of the vehicle using (x2) M8 hex cap screws, (x4) M8 flat washers, (x2) M8 split lock washers, and (x2) M8 hex nuts. One or more holes located on the pinch weld may have to be enlarged using a 5/16"-3/8" drill bit.
5. Secure the support bracket to the main mounting bracket using (x1) M10 hex cap screw, (x2) M10 flat washers, (x1) M10 split lock washer, and (x1) M10 hex nut.
(Do not fully tighten mounting & support brackets at this time)



Westin Automotive Products, Inc.
320 Covina Blvd
San Dimas, Ca. 91773



6. Repeat steps 3-5 for the driver rear mounting bracket and support bracket. Do not fully tighten at this time.

7. At this time attach the driver side step bar to the driver side mounting brackets using (x4) M10 hex socket button head screws, (x4) M10 internal toothed lock washers, and (x4) M10 flat washers.
8. Align all mounting brackets and step bar as desired. Tighten all M8 fasteners to 14 lb-ft. Tighten M10 hex cap screws to 30 lbs-ft. Tighten all M10 button head screws to 18 lbs-ft.
9. Repeat steps 2-8 for passenger side components.



Westin Automotive Products, Inc.
320 Covina Blvd
San Dimas, Ca. 91773

Thank You for choosing Westin products
For Additional installation assistance please call
Customer service (800) 793-7846
www.westinautomotive.com