

INSTALLATION GUIDE

AMP RESEARCH Power Step™

MADE IN USA

APPLICATION
Toyota Sequoia

MODEL YR
2023-2024

PART #
76341-01A

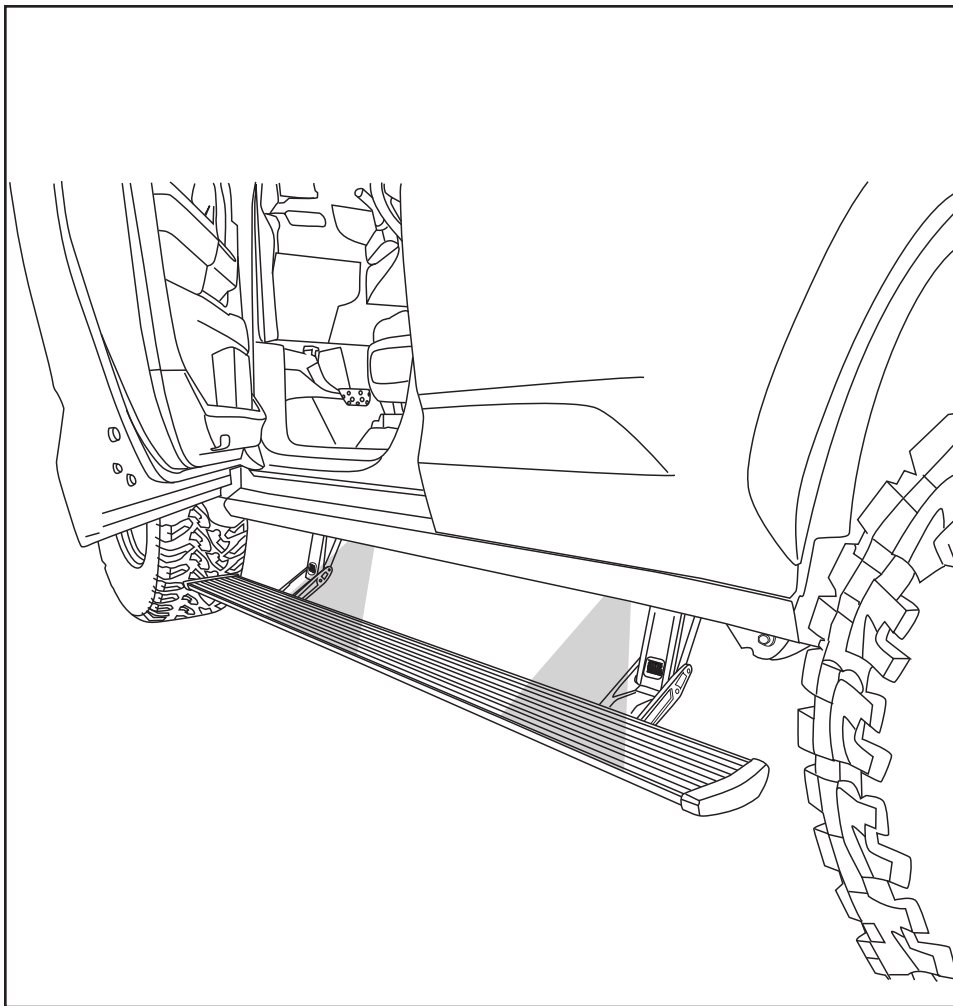

INSTALLATION TIME

3-5 Hours

Professional installation recommended

SKILL LEVEL



4= Experienced

TOOLS REQUIRED

- Measuring tape
- 13 mm socket
- 10 mm socket
- Ratchet wrench and extension
- 13mm end wrench
- Wire stripper / cutter
- 3/16" hex key wrench (allen wrench)
- 5mm hex key wrench (allen wrench)
- 4mm hex key wrench (allen wrench)
- Electrical tape

WARRANTY

5-Year Limited Warranty

AMP RESEARCH TECH SUPPORT 1-888-983-2204 (Press 2) Monday - Friday, 7:00 AM - 5:00 PM PST

Invented, engineered and manufactured exclusively by AMP Research in the USA. May be covered by one OR MORE of the following patents: 6,641,158; 6,830,257; 6,834,875; 6,938,909; 7,055,839; 7,380,807; 7,413,204; 7,398,985; 7,584,975; 7,566,064; 7,487,986; 8,157,277; 8,408,571; 9,302,626; 9,561,751; 10,053,017; CA2463717 ©2023 AMP Research. All rights reserved. Printed in USA.

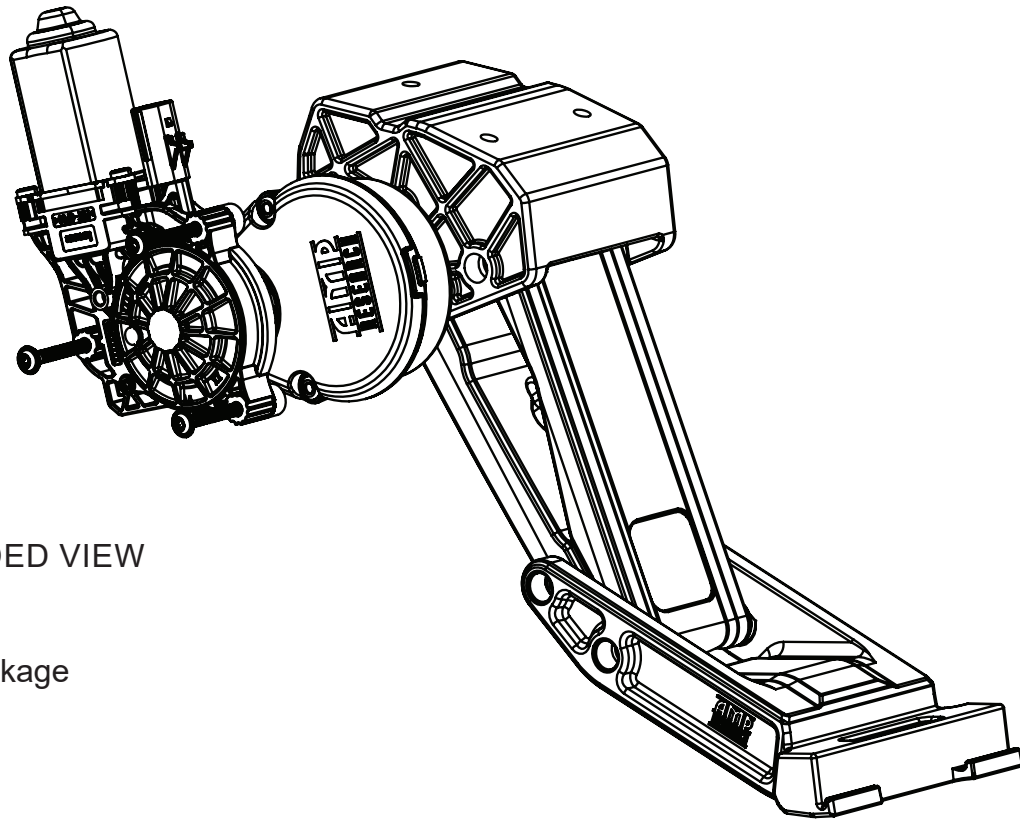

EXPLODED VIEW

Motor Linkage

Motor Kit

Delta PT screws

CAUTION: HANDLE WITH CARE.

To ensure our customers receive all components with full integrity, we pack the motors separate from their linkage assemblies. This requires that the installer position and fasten the motor before continuing with the install. Please follow the instructions below and handle the assembly carefully.

CAUTION: Dropping the assembly or any excessive impact MAY cause damage to the motor.

Instructions:

1. Position the gear cover in place as shown if not already in place.
2. Seat motor into position on the three mounting bosses. This may require an adjustment of the gear by moving the swing arms.
3. After seating into place, fasten the motor with the three motor mount screws with 4mm Hex Head. Tighten screws to 36 in-lbs (4N-m). **Do not over torque.**

AMP RESEARCH POWERSTEP™ – TOYOTA SEQUOIA

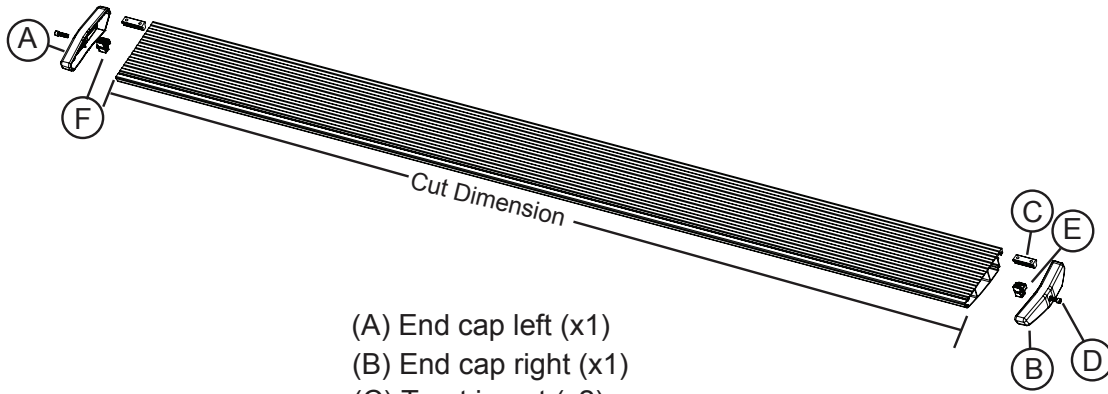

1 x2

Running board assembly

- (A) End cap left (x1)
- (B) End cap right (x1)
- (C) T-nut insert (x2)
- (D) Socket cap screw (x2)
- (E) End cap wedge right (x1)
- (F) End cap wedge left (x1)

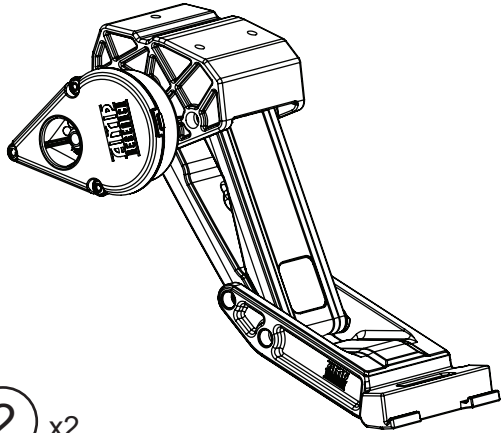

2 x2

Motor linkage assembly

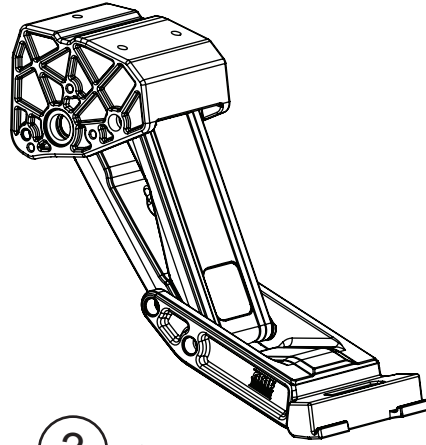

3 x2

Idler linkage assembly

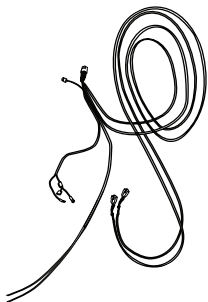

4

Wire harness

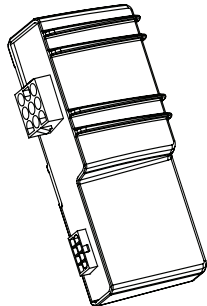

5

Controller STA

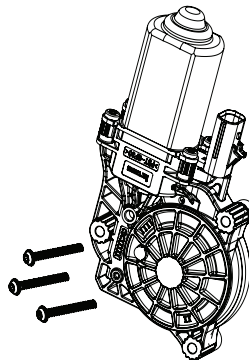

6 x2

Motor Kit

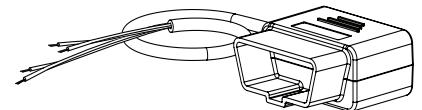

7

OBD II Plug

AMP RESEARCH POWERSTEP™ – TOYOTA SEQUOIA

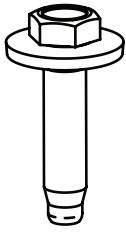

8 x26
M8 Hex Bolt w
Conical washer

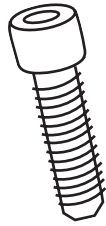

9 x8
Socket Cap Screw

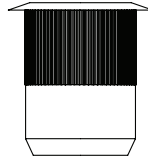

10 x2
Rivet nut

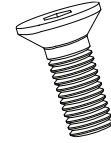

11 x2
Flat Head Torx

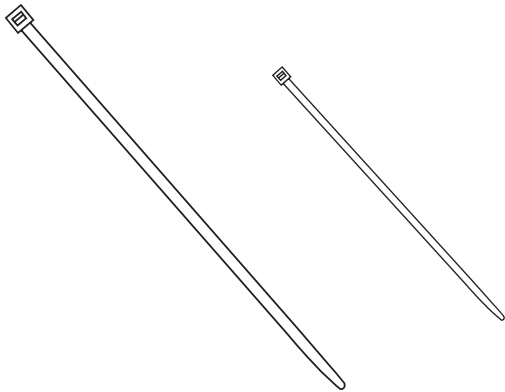

12 x2
Cable tie (11")

13 x20
Cable tie (7")

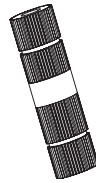

14 x2
Posi-Lock™
(Grey)

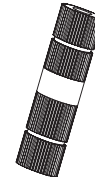

15 x2
Posi-Tap™
(Red/Grey)

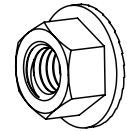

16 x2
1/4-20
Flange Nut

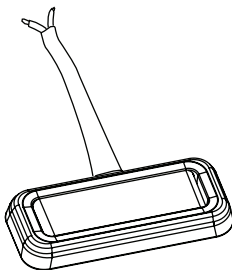

17 x4
LED Lamp

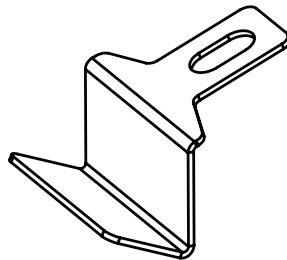

18 x4
LED Light Bracket

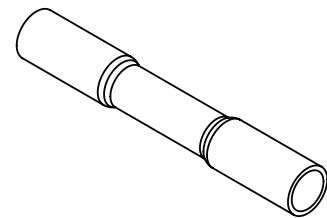

19 x8
Butt Connector

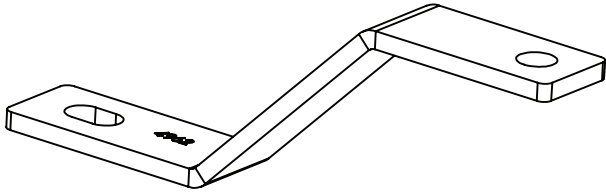

20

Rear Linkage support
Bracket (Driver)



21

Rear Linkage Support
Bracket (Passenger)

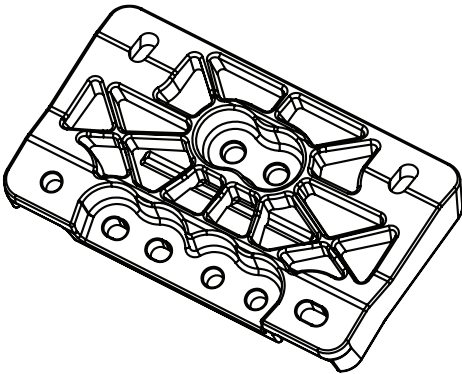

22 x2

Front Linkage mounting
bracket

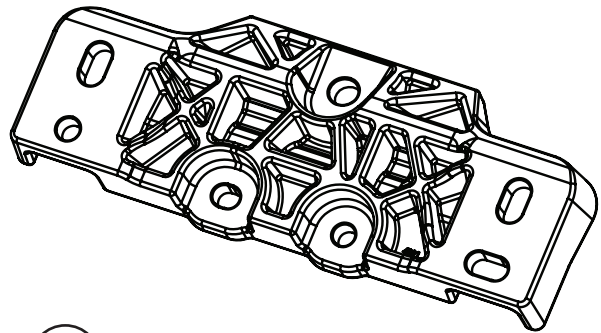

23 x2

Rear Linkage mounting
bracket

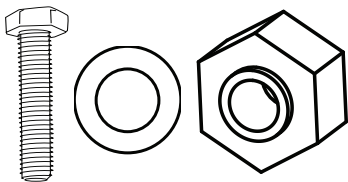

24

Rivet tool nut

Attach Body mount plate (23) to rear drive linkage (2) using 3 supplied conical washer bolts (8). **Torque bolts to 16 ft-lbs.**

Repeat for passenger side.

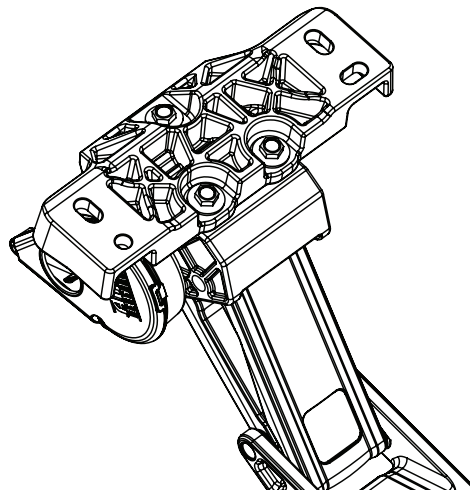

1

Attach Front Body mount plates (22) to front idler linkage (3) using 3 supplied conical washer bolts(8). **Torque bolts to 16 ft-lbs.**

Note: Driver and Passenger side offset. The offset allows the linkage to clear frame when steps are stowed.

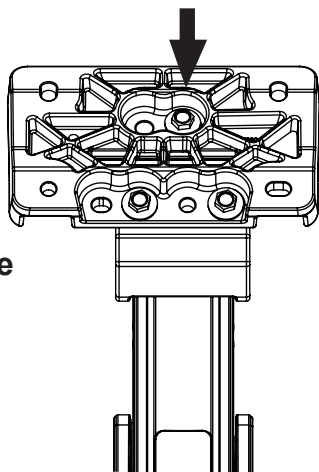

Driver Side

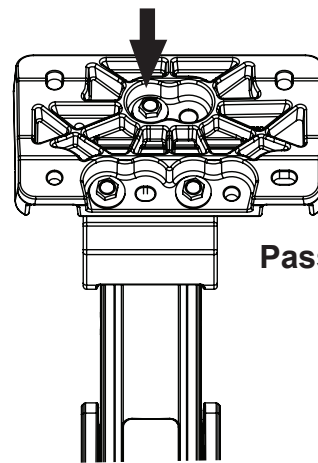

Passenger Side

2

Locate 3 mounting points at front and rear of vehicle. If factory screws are in place, use 12mm socket and remove screws.

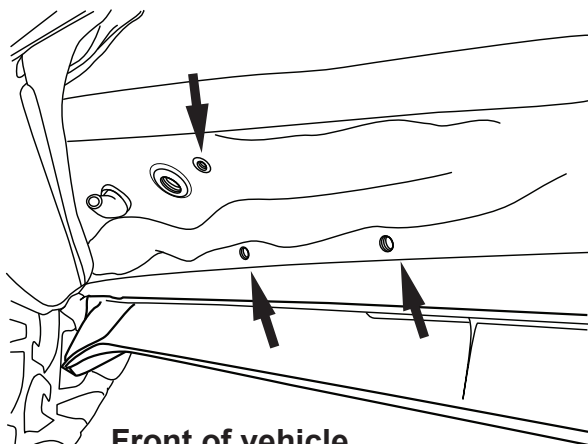

Front of vehicle

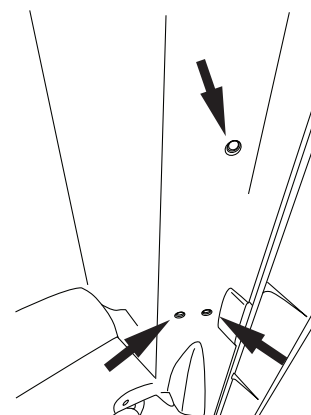

Rear of vehicle

3

Attach front Idler linkage assembly (double check offset noted in step 2). On rear most bolt install light bracket (18) as shown. Use 3 supplied conical washer bolts (8) to attach linkage assembly to body of truck. **Torque bolts to 16 ft-lbs.**

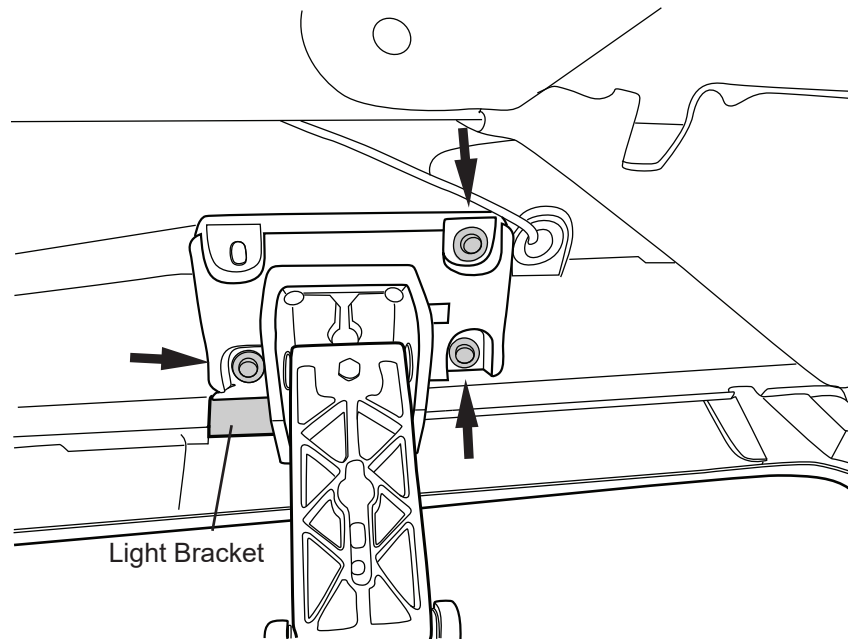
**4**

Attach rear drive linkage (2) assembly as shown. On forward most bolt install light bracket (18) as shown. Use 3 supplied conical washer bolts (8) to attach linkage assembly to body of truck. Snug bolts into position. **Torque bolts to 16 ft-lbs.**

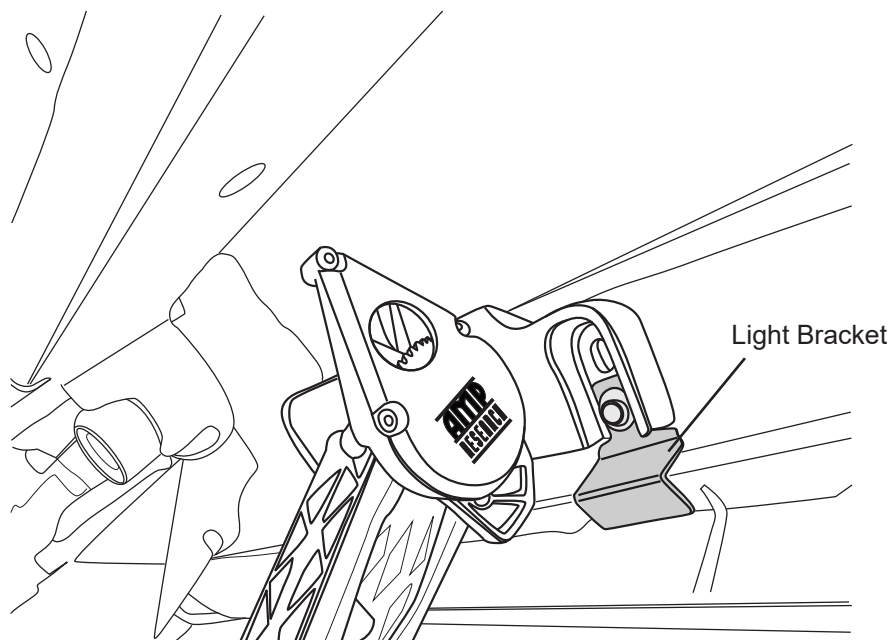
**5**

Slide mounting T-nut into position. Place the board (1) about 9" from the back edge of the lower mount to the rear endcap. Tighten all fasteners (9) to 10ft-lbs.

Repeat steps 3-6 on passenger side of vehicle.

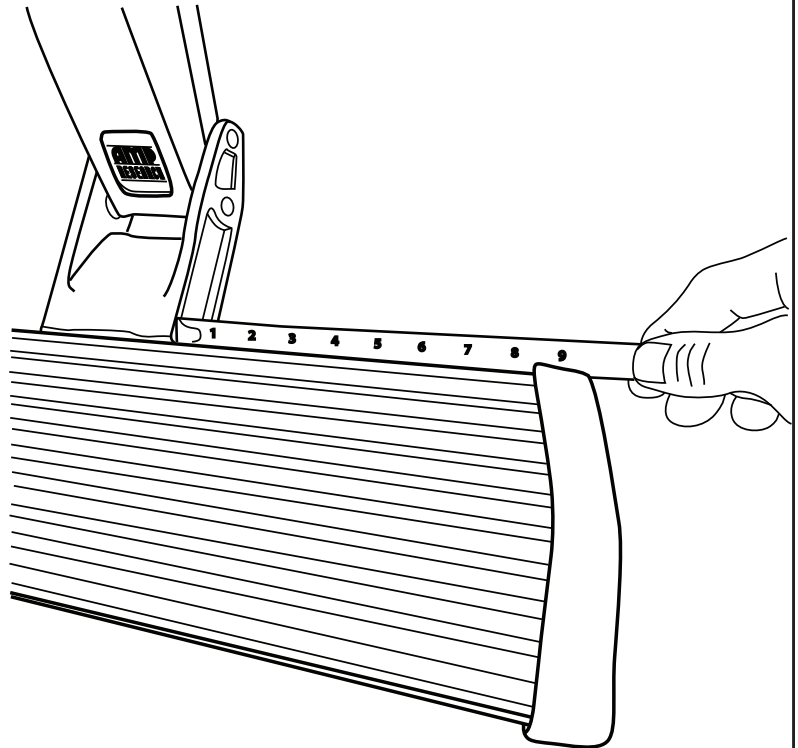

6

On Driver side(20) bracket into place. Use supplied torx head screw (11) and flange nut (16) to attach bracket to driver rear upper mount. Rotate bracket up to position shown. Use bracket to locate hole using an 1/8" drill. Drill hole thru body sill gusset. Rotate bracket out of the way and drill using a 17/32 drill. Install supplied rivet nut(10) using rivet nut tool(24). Rotate bracket into place and use supplied Conical washer bolt(8) to attach bracket. Repeat for Passenger side.

Note driver and passenger side brackets are different.

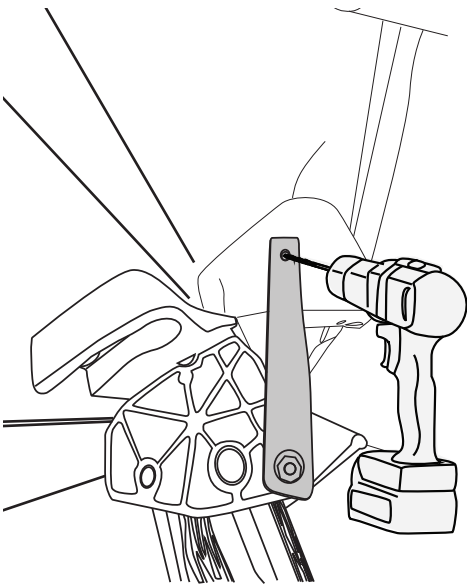

Driver Side

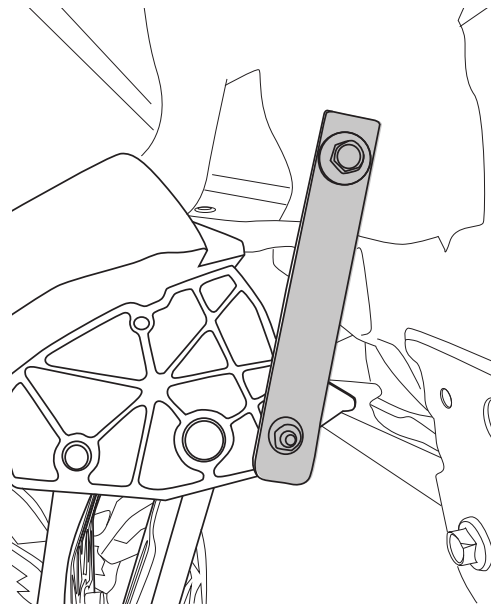

Passenger Side

7

Remove power fuse.

Connect wire harness (4) to controller (5) and secure locking clip.

Connect red power lead to positive terminal in fuse box as shown and black ground lead to grounding lug on fender apron.

Use supplied 11" zip ties (12) to attach controller to battery bracket.

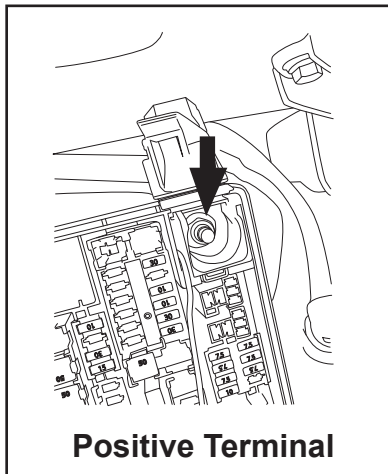

Positive Terminal

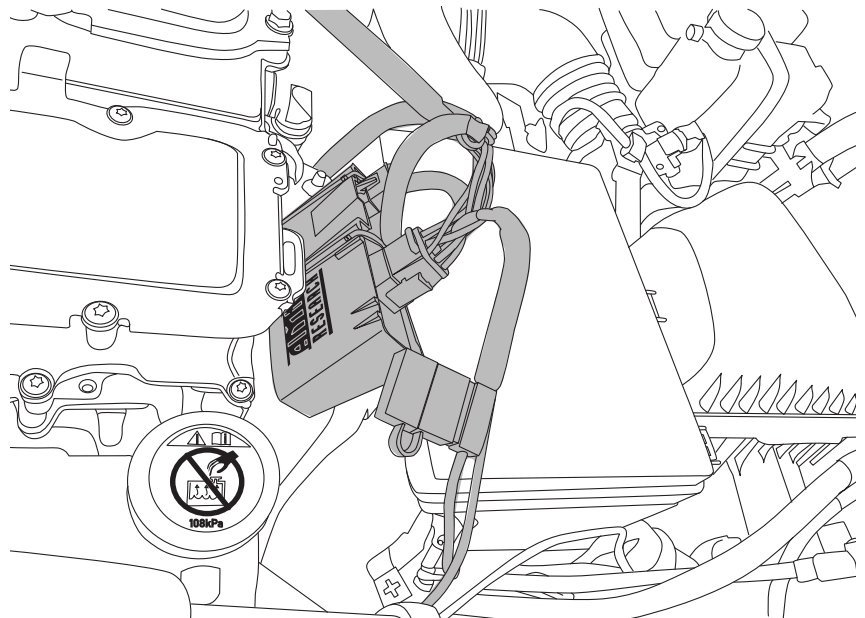

8

Route longest leg of wire harness across fire wall to driver side and under vehicle outside of frame rail. Route shorter leg of wire harness down passenger side fender well and under vehicle outside of frame rail. Use supplied 7" zip ties (13) where needed to secure harness.

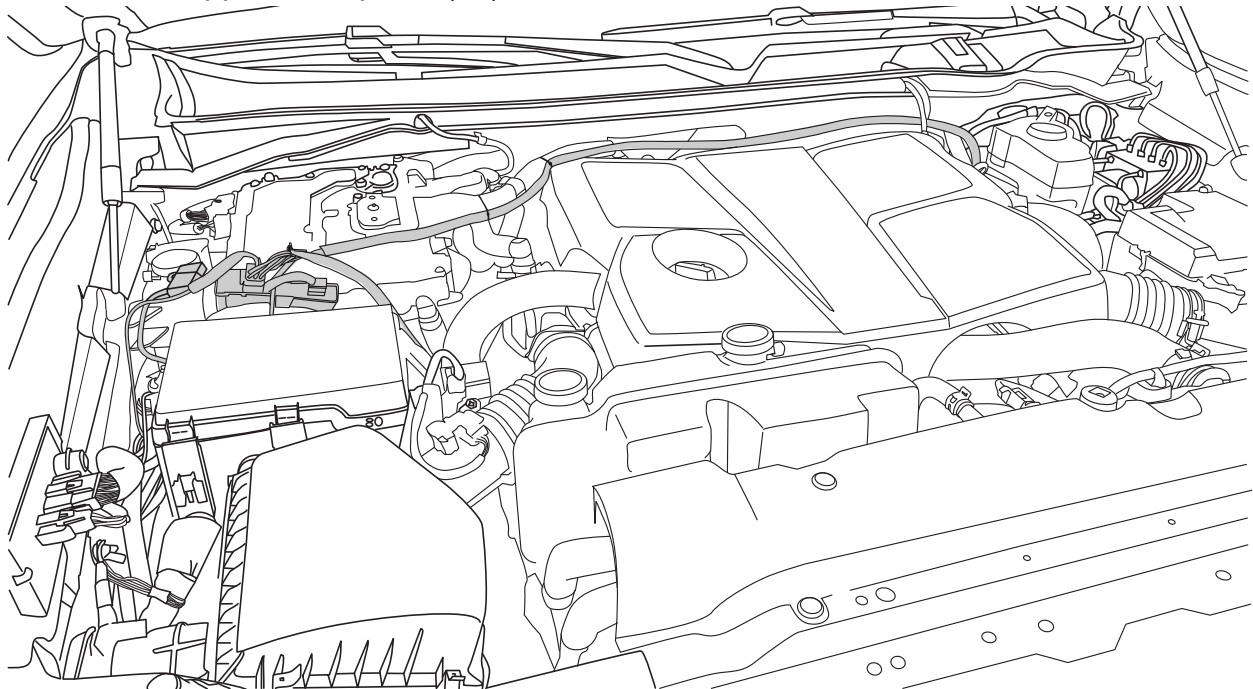

9

Remove driver front sill plate and kick panel. Pull up carpet. Locate rubber grommets under carpet in floorboards.

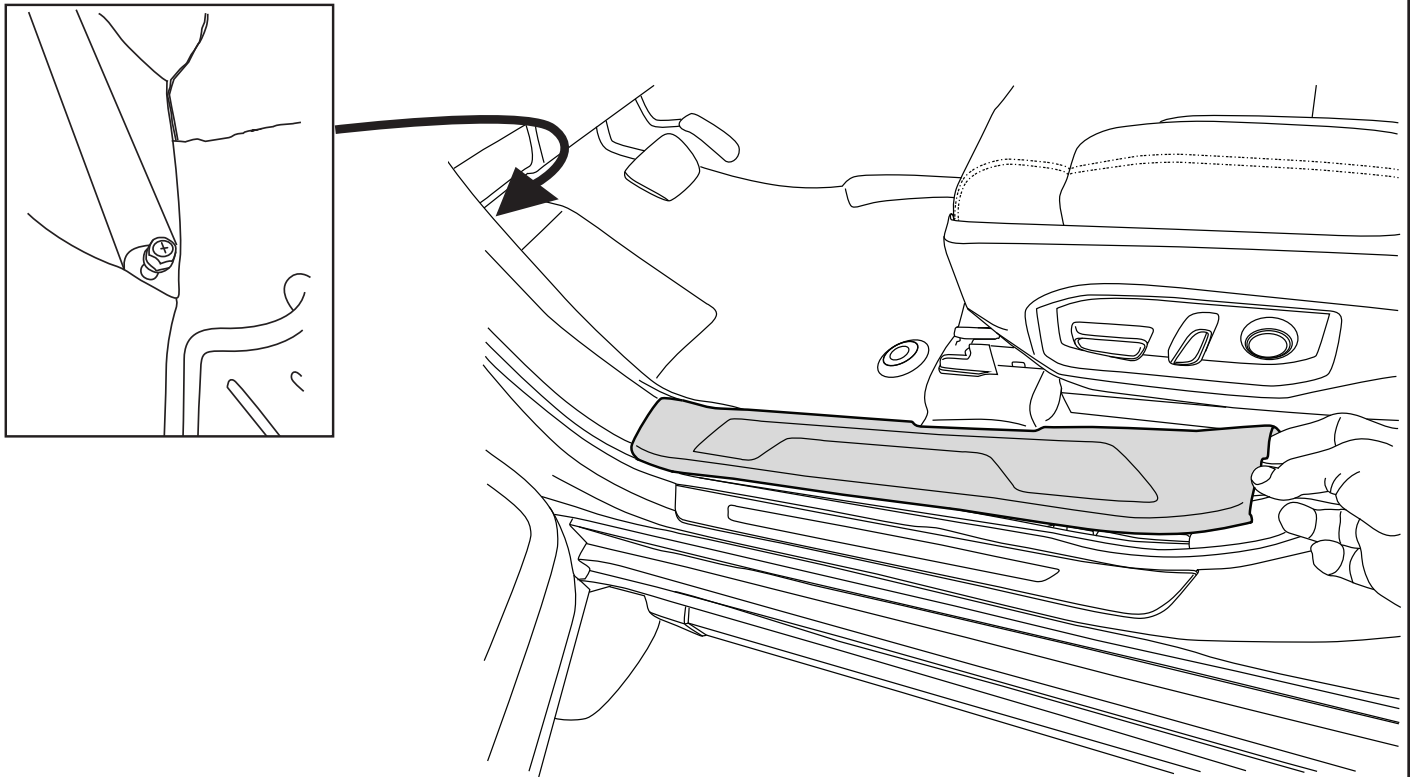

10

Cut a slit in the rubber grommet and pass the trigger wires up through grommet under carpet on the driver side.

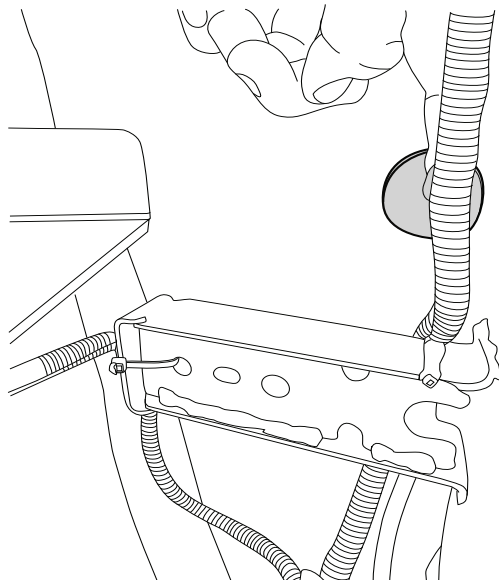

11

Posi-Tap™ instructions

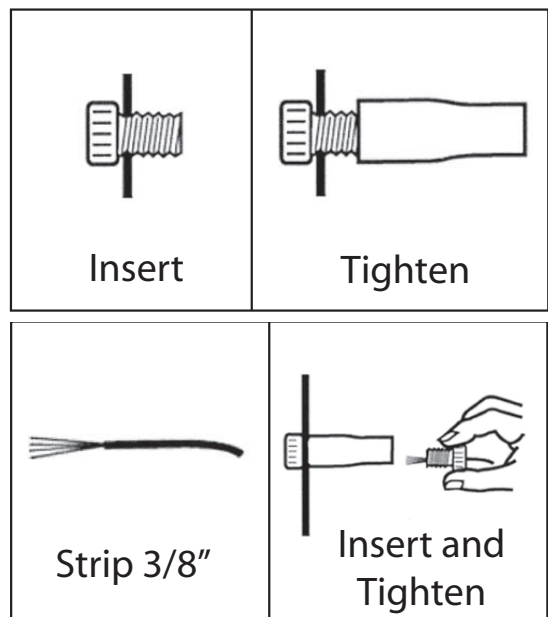

12

Locate white plug in driver kick panel area. Disconnect battery to avoid a Check Engine Light. Once battery is disconnected unplug plug to gain access. Locate the white and blue wire as shown in the plug. Using supplied posi-taps™ (15) connect the blue wire on the DSM to the white wire on the factory plug.

Next, connect the white wire on the DSM module (7) to the blue wire on the factory plug. Reconnect white factory plug.

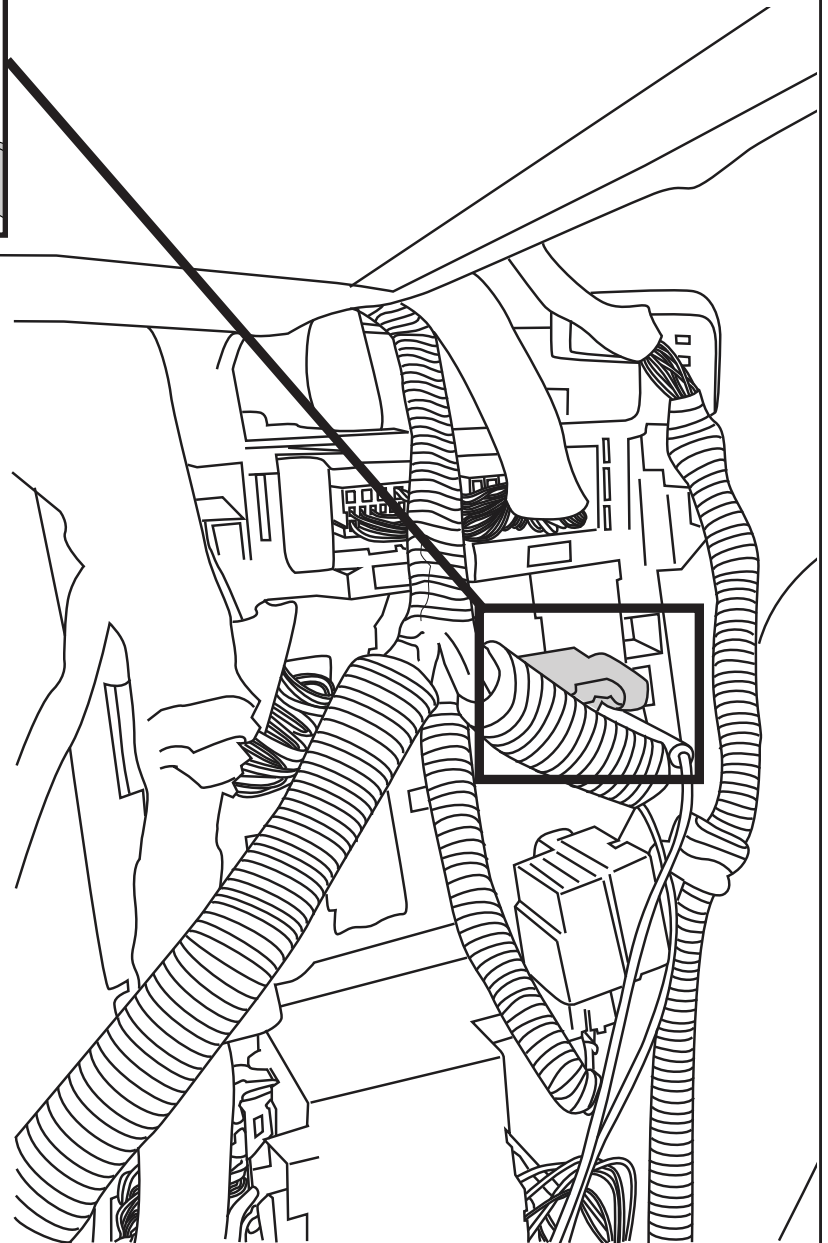
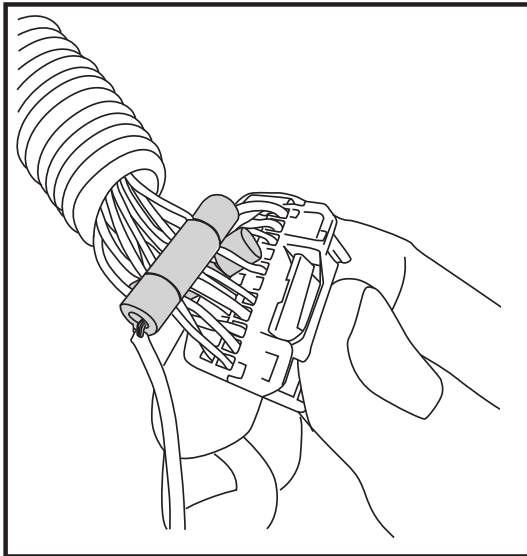
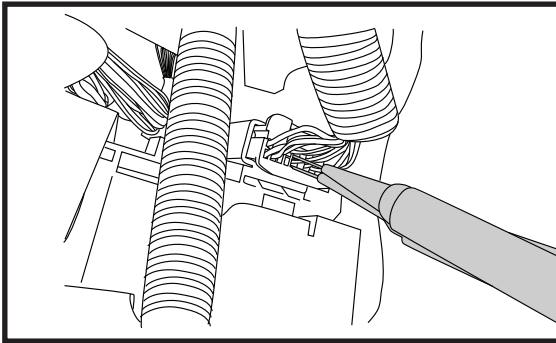

OBD II install: Use Supplied Posi-lock™ (14) connectors to attach the Plug and Play Module to the Harness. Attach matching colors on the harness to the wires on the module. Plug in OBD module (7) to OBD II port on the vehicle. Secure harness with supplied tie wraps (13). **Note: If the OBD II pass thru harness (76405-01A) was purchased see install sheet supplied in packaging. The pass through harness allows for an open port for other accessories. See below for images with brief descriptions.**

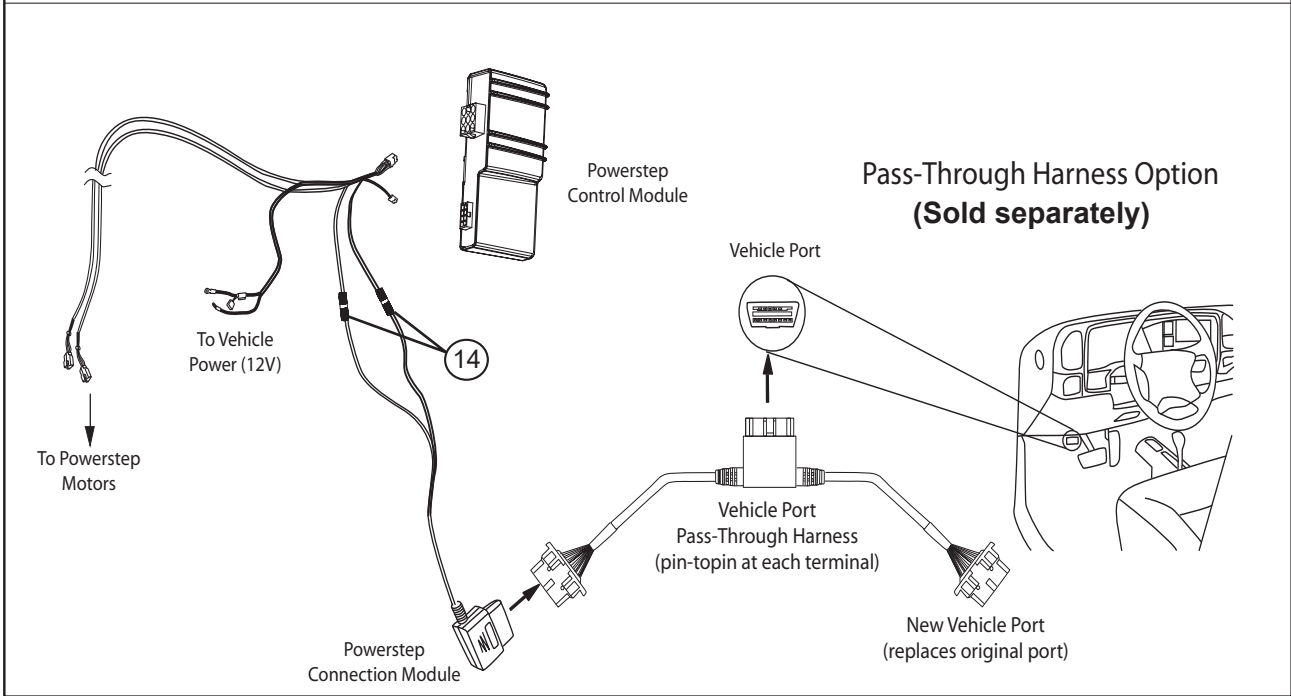
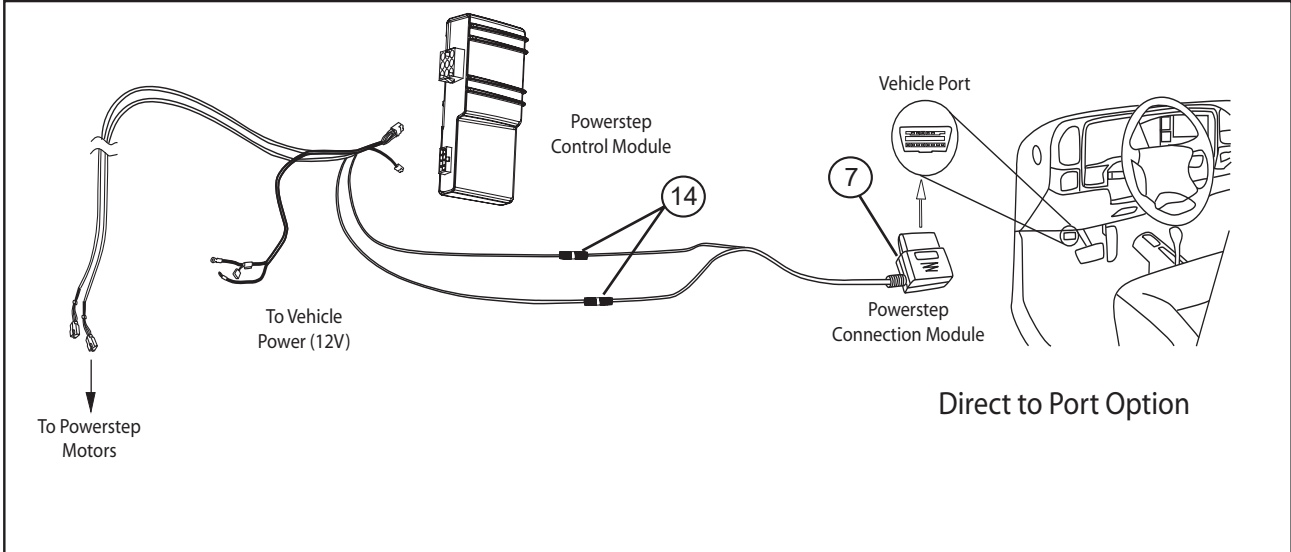

Plug in module to OBD port on the vehicle.

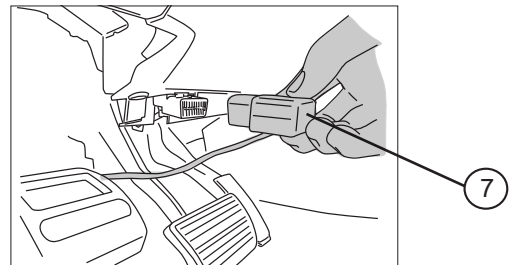
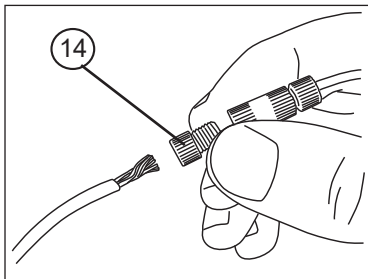

Attach Supplied LED lamps(17) to light brackets(18) as shown. Using supplied butt connectors connect the lamp wires. Red to red, black to black. Once crimped use heat gun to shrink tube.

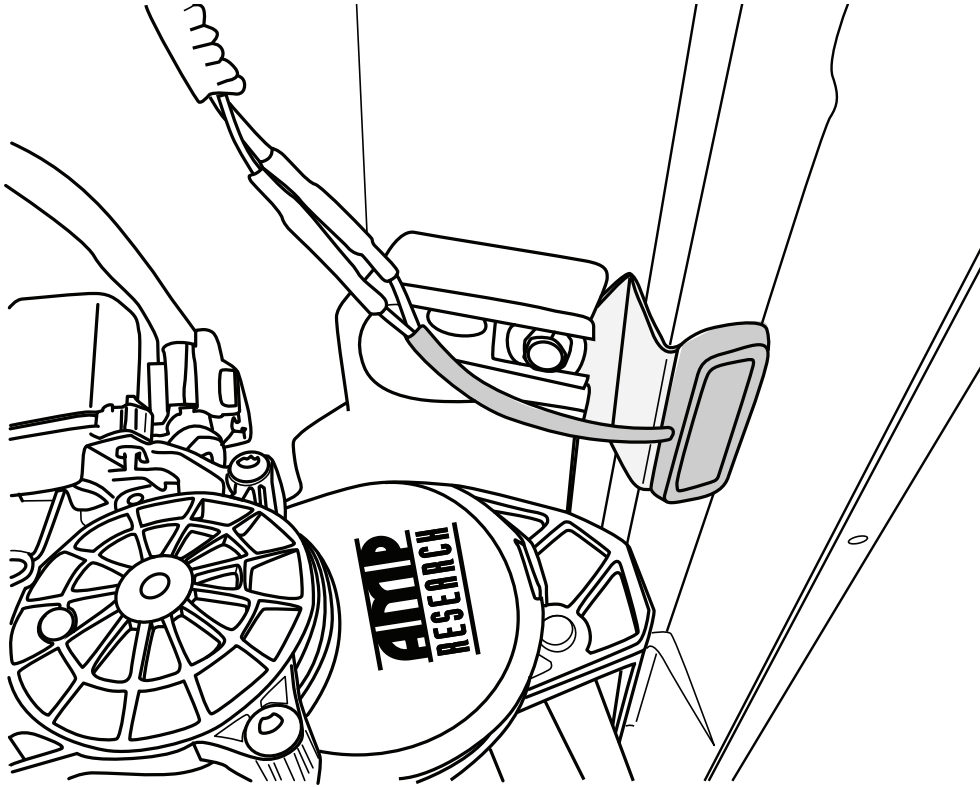

15

Close and wrap with conduit and electrical tape. Secure all loose wires with cable ties, with lamp wires pulled upward to avoid any wire snagging.

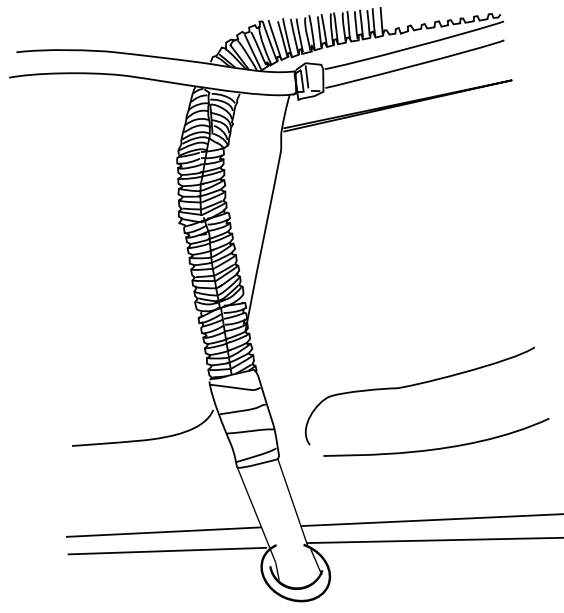

16

Reinstall fuse, then check that all doors activate the Power Step and the LED Lights work when doors open and close. Reinstall any remaining trim panels.

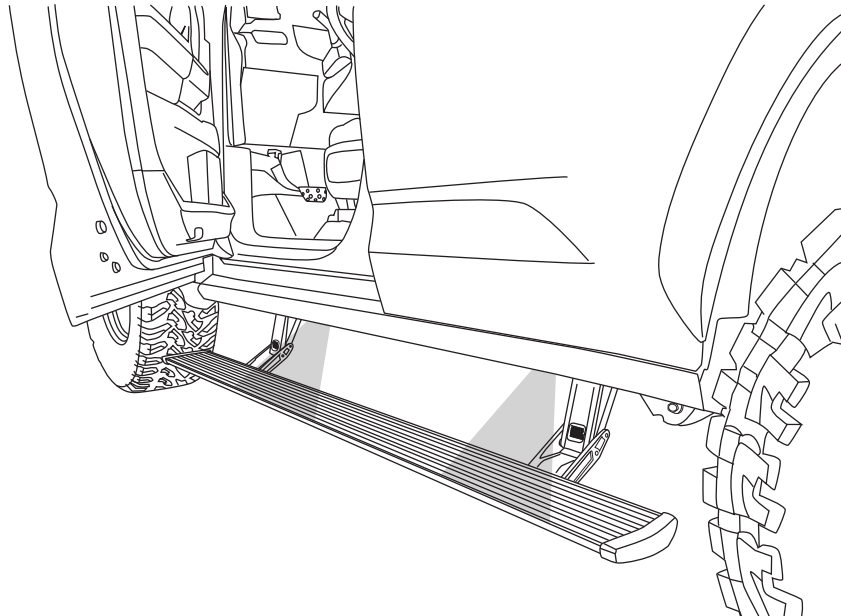
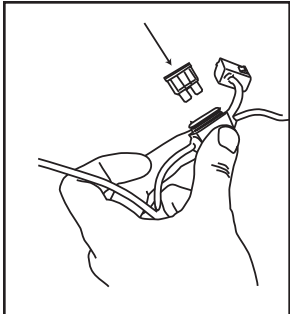

SYSTEM CHECK

Check that all doors activate the PowerStep and the LED lights work when doors open and close.

NORMAL OPERATION: When the doors open, PowerStep automatically deploys from under the vehicle. When the doors are closed, PowerStep will automatically return to the stowed/retracted position. **Note that there is a 2-second delay before the PowerStep returns to the stowed/retracted position.**

CORRECT OPERATION OF LIGHTS: All four lamps will illuminate upon opening any door of vehicle. Lamps will stay on until restowing of both Power Steps or until 5 minutes has expired with the doors open. When the lights timeout after 5 minutes, they can be reilluminated by closing and opening any door of vehicle.

17

Because the factory plug was removed a key cycle is required to activate the DSM module.

Started the vehicle then shut off the vehicle. Next plug in the DSM module (7), open and close door. The steps should deploy.

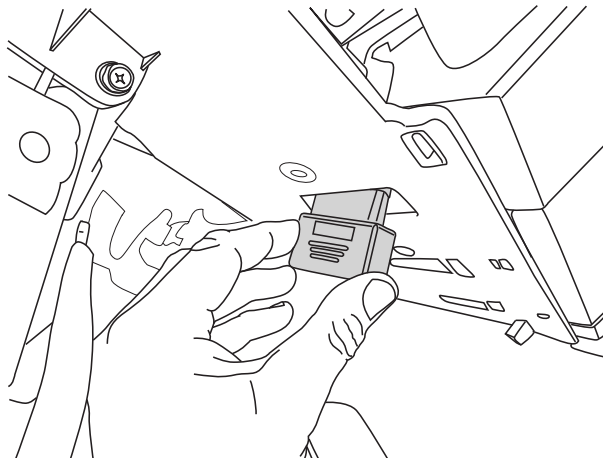

18

AMP **RESEARCH** **Power Step**™

AMERICAN DESIGNED, ENGINEERED AND MANUFACTURED.

Thank you for your recent AMP Research Purchase.

REGISTER YOUR PRODUCT TODAY FOR FASTER SERVICE & PRODUCT UPDATES

Please visit:

www.amp-research.com/productregistration
or scan the QR Code



Product Registration Benefits:

- Ensure we have your purchase receipt and product info in our system which is required for warranty
- Faster and easier access to customer service and tech support in the unlikely event you need warranty or product support
- Registration helps us keep you up to date on product information and offers

To view other Amp Research products that may be offered for your vehicle.

Please visit: www.amp-research.com

Rev 01.05.21

POWER-DEPLOYABLE RUNNING BOARDS OPERATION: AMP Research PowerStep running boards automatically move when the doors are opened to assist entering and exiting the vehicle.

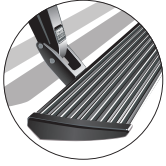

Automatic power deploy:

The running boards will extend down and out when the doors are opened.

Automatic power stow:

The running boards will return to the stowed position when the doors are closed. There will be a 2-second delay before the running boards move to the stowed position.

Automatic stop:

If an object is in the way of the moving running board, the running board will automatically stop. To reset, clear any obstruction, then simply open and close the door to resume normal operation.



Manually set in the deployed (OUT) position for access to the roof:

The running boards can be manually set in the deployed position by firmly holding the step down with your foot while at the same time closing the door. To resume normal operation, open and close the door.

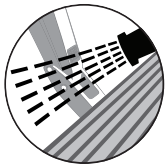

Maintenance: In adverse conditions, debris such as mud, dirt, and salt may become trapped in the running board mechanism, possibly leading to unwanted noise. If this occurs, manually set the running boards to the deployed position and flush the front and rear hinge arms with a high-pressure car wash wand.

Avoid spraying the motors directly. After washing, apply silicone spray lubricant to the hinge pivot pins.

Do not apply silicone, wax or protectants like Armor All® to the running board stepping surface.

Caution! Keep hands away when the running board is in motion.

5-YEAR LIMITED WARRANTY

AMP RESEARCH warrants this product to be free from defects in material and workmanship for FIVE (5) YEARS FROM DATE OF PURCHASE, provided there has been normal use and proper maintenance. This warranty applies to the original purchaser only. All remedies under this warranty are limited to the repair or replacement of the product itself, or the repair or replacement of any component part thereof, found by the factory to be defective within the time period specified. The decision to repair or replace is wholly within the discretion of the manufacturer.

This warranty specifically excludes labor. If you have a warranty claim, first you must call our factory at the number below for instructions. You must retain proof of purchase and submit a copy with any items returned for warranty work. Upon completion of warranty work, if any, we will return the repaired or replaced item or items to you freight prepaid. Damage to our products caused by accidents, fire, vandalism, negligence, misinstallation, misuse, Acts of God, or by defective parts not manufactured by us, is not covered under this warranty.

ANY IMPLIED WARRANTIES OF MERCHANTABILITY AND/OR FITNESS FOR A PARTICULAR PURPOSE CREATED HEREBY ARE LIMITED IN DURATION TO THE SAME DURATION AND SCOPE AS THE EXPRESS WRITTEN WARRANTY. OUR COMPANY SHALL NOT BE LIABLE FOR ANY INCIDENTAL OR CONSEQUENTIAL DAMAGE.

Some states do not allow limitations on how long an implied warranty lasts, or the exclusion or limitation of incidental or consequential damages, so the above limitations or exclusions may not apply to you. This warranty gives you specific legal rights, and you may also have other rights that vary from state to state.

FOR WARRANTY ISSUES WITH THIS PRODUCT PLEASE CALL AMP RESEARCH TECH SUPPORT 1-888-983-2204

WARNING

Be sure to read and precisely follow the provided instructions when installing this product. Failure to do so could place the vehicle occupants in a potentially dangerous situation. After installing or reinstalling, re-check to insure that the product is properly installed.



The material that your product is made from can be recycled. Please also consider recycling the packaging that your product came in.

