

Bugflector / Bugflector II[®] Carflector[™]

Quick and Easy Installation Instructions

CONTENTS

- | | |
|----------------|-----------------------|
| (1) Bugflector | (4) phillips screws |
| (4) Bump-ons | (4) hood inserts |
| (4) washers | (1) instruction sheet |

IMPORTANT: Read all instructions carefully before beginning installation. Installation utilizes the existing square holes in the hood which align with the holes in the Bugflector. The ideal installation temperature is between 65°-110°F (18°-43°C).

STEP 1

Raise the hood and locate the (4) square holes on the underside of the hood. Clean this area with a cloth to remove any dust or debris which may affect the mounting of the Bugflector. See **FIGURE 1**

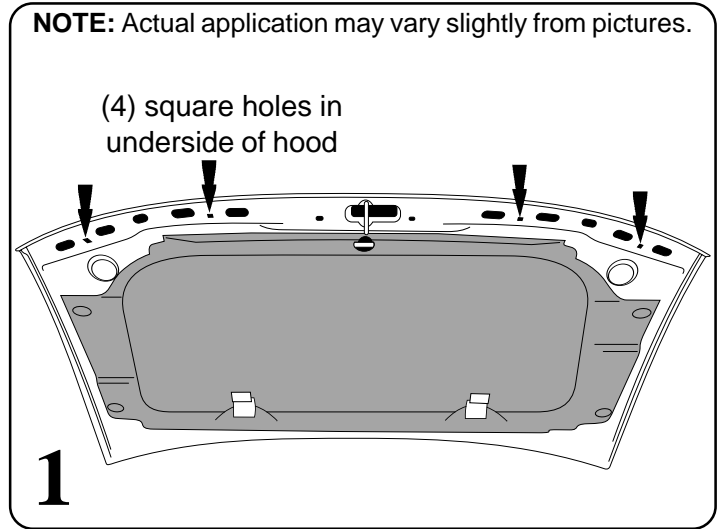

STEP 2

Press the (4) hood inserts into the (4) square holes. If necessary, use clear tape to hold them firmly in place. See **FIGURE 2 (Close-up)**

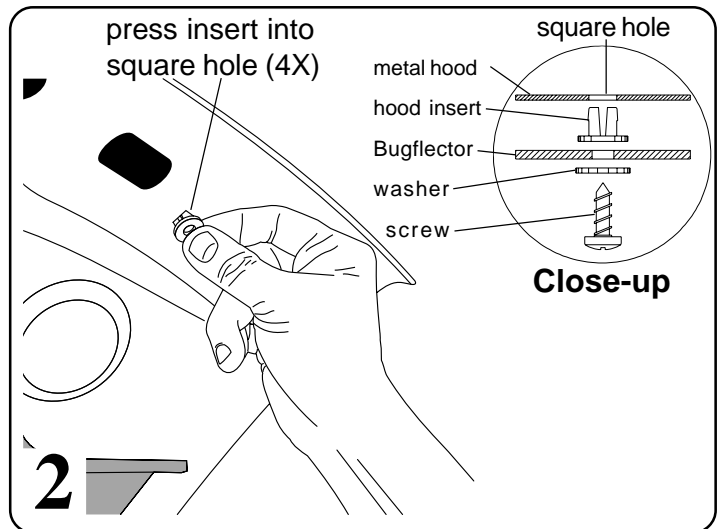

STEP 3

Align the predrilled holes in the Bugflector with the holes in the hood inserts. Using a Phillips screwdriver, install the (2) center screws. **TO PREVENT STRIPPING HOOD INSERTS SCREW UNTIL SNUG; DO NOT OVERTIGHTEN.** Repeat procedure for the remaining holes. See **FIGURE 2**

Note: For applications with tape, peel back liner to expose a portion of the adhesive. Then align deflector with holes in hood and install mounting hardware. Lastly, remove the remaining tape liner by pulling free end and press on tape surface to ensure proper adhesion to underside hood.

STEP 4

To reduce vibration, adhere the Bump-ons at pre-cleaned locations **on the painted hood/fender surface** where the Bugflector may contact. If the hood will not shut properly, it may be necessary to adjust the hood bumper stops (refer to your owner's manual). See **FIGURE 3**

