



n-fab.com

mfabinc f t

I-SHEET NUMBER: INST-00065
 PART NUMBER: D09-RCTX
 PRODUCT: GROWLER RUNNING BOARD
 APPLICATION: RAM 09-18 1500 10-20 2500-3500

HARDWARE DESCRIPTION		QTY.
HWKT-05483X		
HHCS-00568X	3/8"-16 X 1" GRADE 5 HEX CAP SCREW	4
FLTW-00663X	3/8" USS FLAT WASHER ZINKLAD 1000B	4
CLIP-00647X	3/8"-16 X 1 3/4" BARREL NUT CLIP	4
FLHB-00797X	M8-1.25 X 25MM CLASS 8.8 HEX SERRATED FLANGE BOLT ZINKLAD 1000B	4
FLNT-00696X	M8-1.25 CLASS 8 SERRATED FLANGE NUT	4
FLHB-00688X	3/8"-16 X 1" GRADE 5 HEX SERRATED FLANGE	8
PARTS INCLUDED		QTY
Running Boards		2
Rocker Panel mounting Brackets		4
Threaded clamp plates		4



GROWLER

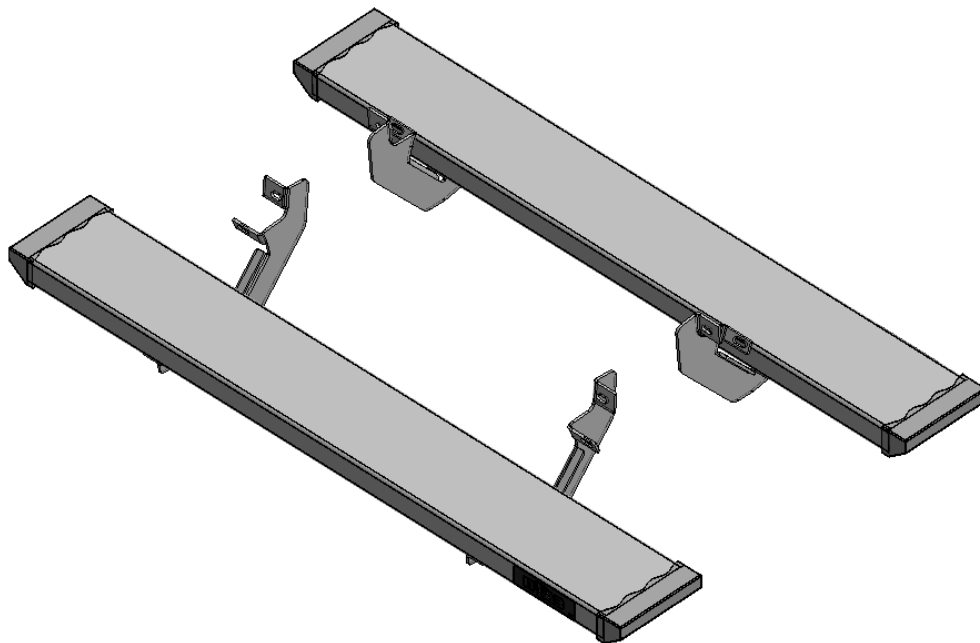

Step 1: Beginning with the driver side, remove any factory running boards or steps and discard.
Step 2: Next, locate the mounting holes underneath the body and remove the factory tape from the two locations.

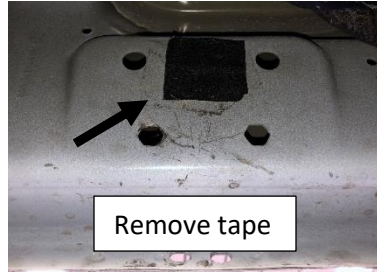

Step 3: Insert the supplied threaded U- clips in each mounting location.

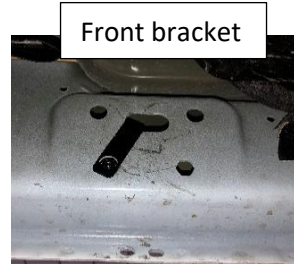

U-clip positioning. **NOTE:** *U- Clip orientation will be the same for passenger*

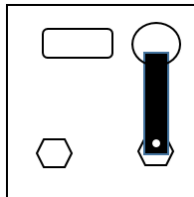

NOTE: *If you have a 14-18 model you may have to drill a 1" round opening for the rear bracket location to add the clip. If so, go ahead and complete this step at his time.*

Step 4: *Some models may require drilling a hole in the pinch weld for the bottom mounting position. To do this, line up the mounting bracket with upper clip and make a mark on the pinch weld. With a 3/8" drill bit, drill a hole in the center. If this step is required, do so now.*



Step 5: Install the (x2) rocker panel mounting brackets to the factory attachment points using the provided 3/8" x 1" hex bolts and 3/8" flat washers for the upper mount and the M8x25mm flanged bolt and M8 flanged nut for the pinch weld mount. Leave loose for now.

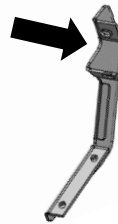

NOTE: Make sure the brackets are facing in the correct direction.

Step 6: Set running board along the top of both brackets and center along the cab.

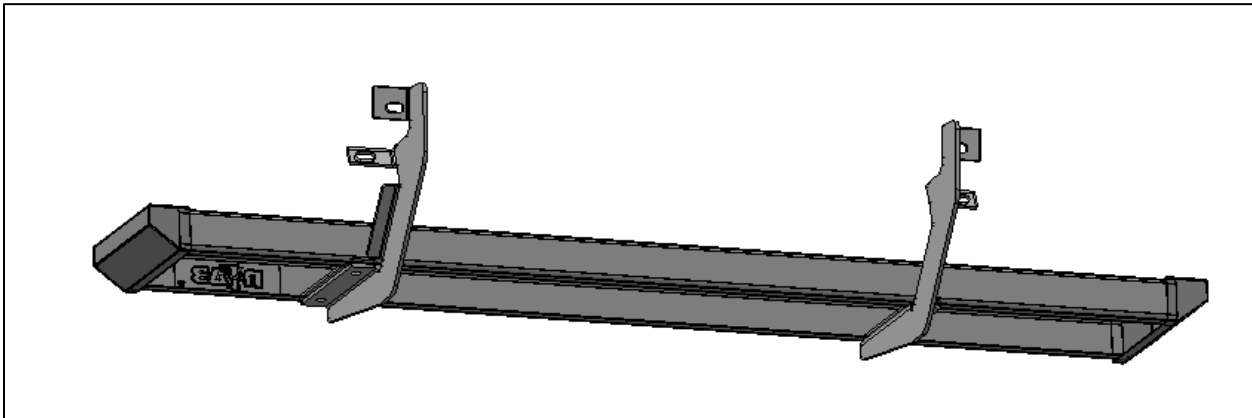

Step 7: Insert the supplied threaded brackets (x2) inside the running board lip over the top of each bracket.

Step 8: With the supplied 3/8" x 1" hex bolts, secure each mounting location and leave loose.

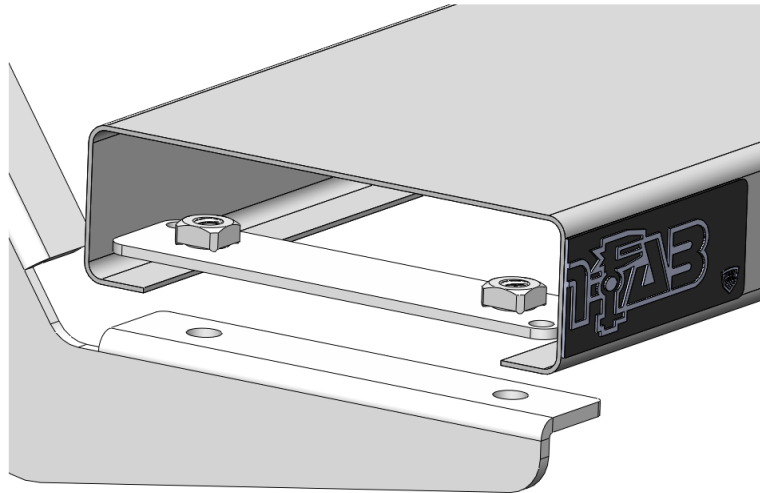

Step 9: After final adjustment, tighten all running board threaded mounts.

Step 10: Next, tighten the lower pinch weld attachment points (x2).

Step 11: Finish by tightening the upper mounts (x2).

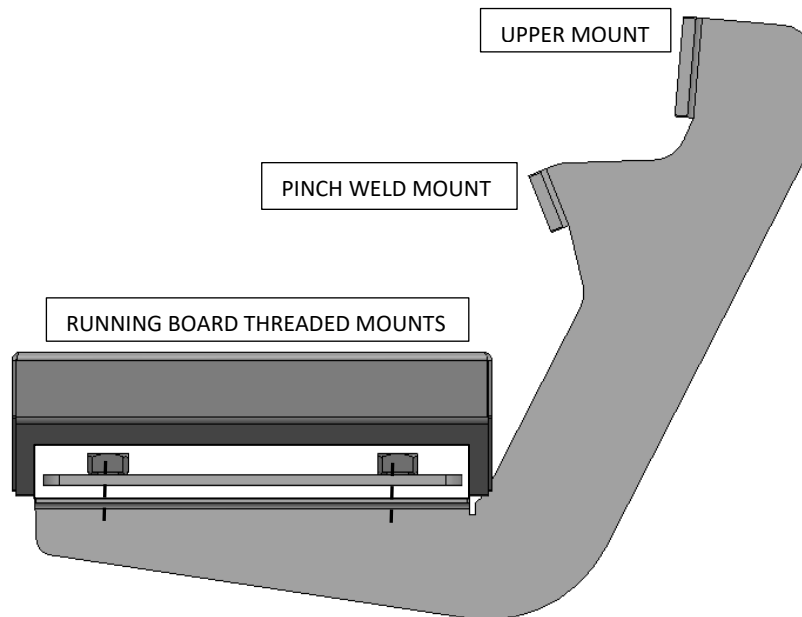

Step 12: Repeat steps 2-11 for passenger side.