

INSTALLATION GUIDE

AMP RESEARCH **Power Step** MADE IN USA

| APPLICATION | MODEL YR | PART # |
|----------------------------|-------------|-----------|
| Toyota Tundra Double Cab * | 2007 - 2018 | 75137-01A |
| Toyota Tundra CrewMax | 2007 - 2018 | 75137-01A |
| Toyota Sequoia * | 2008 - 2017 | 75137-01A |

*Modification required to running board assembly. See Item 1 on page 2.

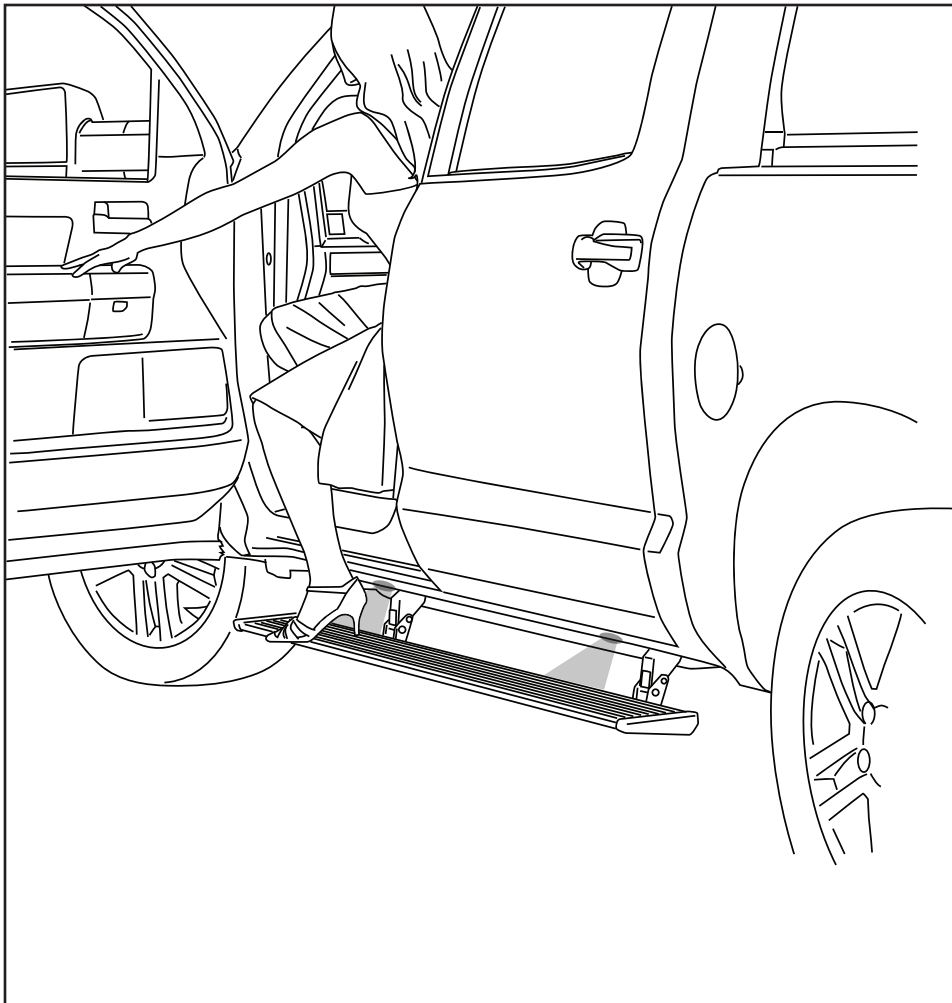

INSTALLATION TIME

3-5 Hours

Professional installation recommended

SKILL LEVEL



4= Experienced

TOOLS REQUIRED

- Measuring tape
- 13 mm socket
- 10 mm socket
- Ratchet wrench and extension
- 13mm end wrench
- Wire stripper / cutter
- 3/16" hex key wrench (allen wrench)
- 5mm hex key wrench (allen wrench)
- 4mm hex key wrench (allen wrench)
- Electrical tape

WARRANTY

5-Year Limited Warranty

AMP RESEARCH TECH SUPPORT 1-888-983-2204 (Press 2) Monday - Friday, 6:00 AM - 5:00 PM PST

Invented, engineered and manufactured exclusively by AMP Research in the USA. May be covered by one of the following patents: 6,641,158; 6,830,257; 6,834,875; 6,938,909; 7,055,839; 7,380,807; 7,398,985; 7,584,975 ©2012 AMP Research. All rights reserved. Printed in USA.

Note: Some Applications require modification.

| Application | Cut Length |
|----------------------|--------------------------------|
| Crew Max | 79" (No Modification Required) |
| Double Cab / Sequoia | 63.5" (Trim 15.5") |

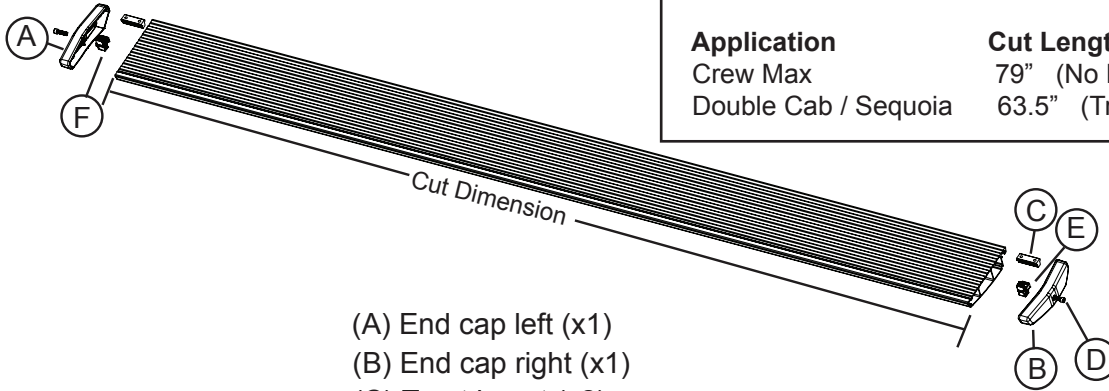

- (A) End cap left (x1)
- (B) End cap right (x1)
- (C) T-nut insert (x2)
- (D) Socket cap screw (x2)
- (E) End cap wedge right (x1)
- (F) End cap wedge left (x1)

1 x2

Running board assembly

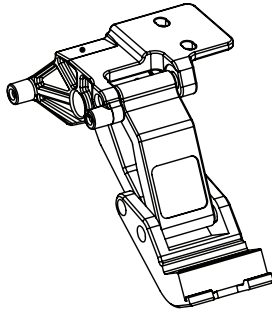

2 x2

Idler linkage assembly

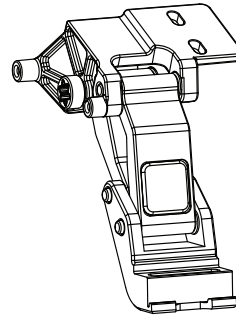

3 x2

Motor linkage assembly

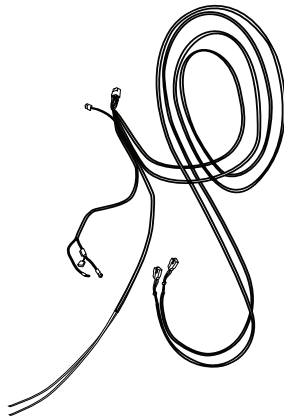

4

Wire harness

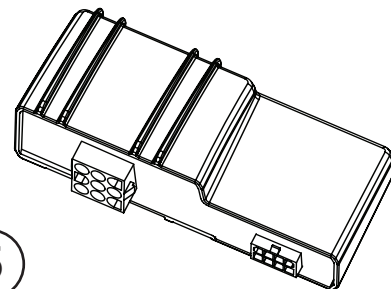

5

Controller STA

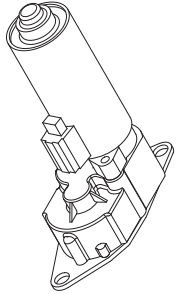

⑥ x2
Motor

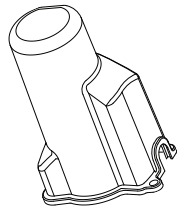

⑦ x2
Motor Cover



⑧ x6
Cinch Fastener

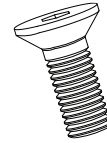

⑨ x4
Socket Cap Screw

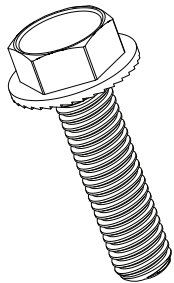

⑩ x8
Hex Flange Bolt

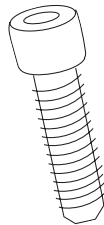

⑪ x8
Socket Cap Screw

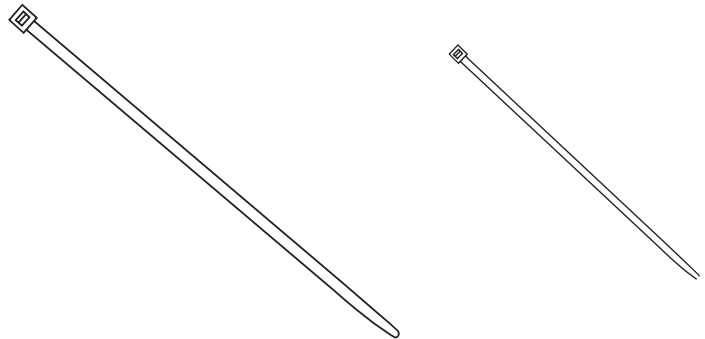

⑫ x2
Cable tie (11")

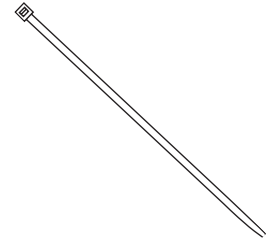

⑬ x20
Cable tie (7")



⑭ x4
Posi-Tap™

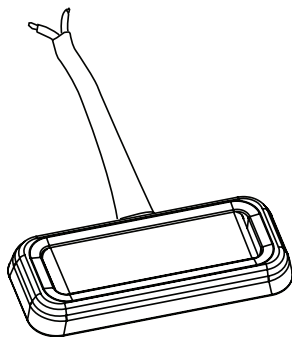

⑮ x4
LED Lamp

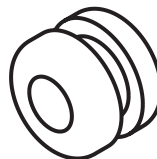

⑯ x4
Grommet

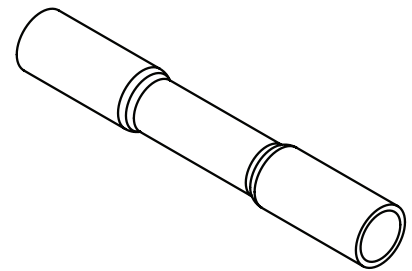

⑰ x8
Butt Connector

**STEP 1 & 2 for CREW MAX ONLY.
All others skip to step 3**

Remove parking brake cable support from frame. Separate bracket and remove bracket from brake cable. Flip bracket 180 degrees to cable.

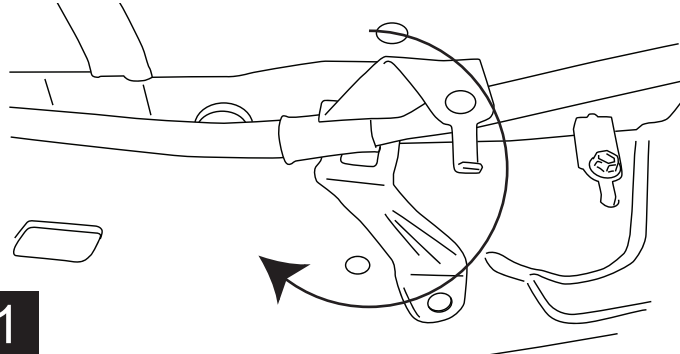

1

Secure parking brake cable support to frame so that the bolt is now below the cable.

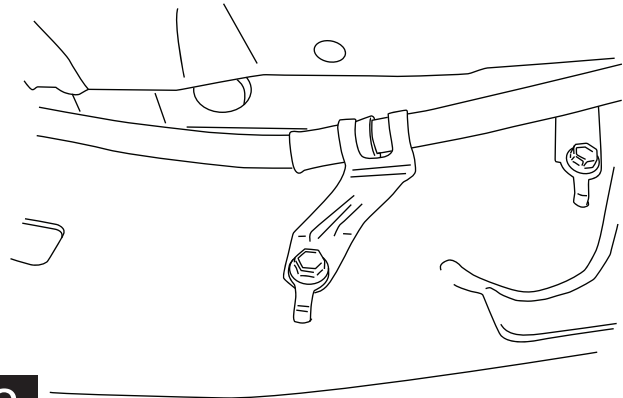

2

Slide motor assembly onto drive shaft and mounting bosses of driving linkage assembly. Use socket head cap screws (9) and tighten to 8 ft-lbs / 11Nm.

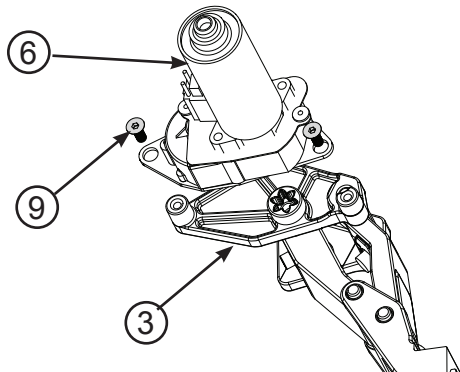

3

Install motor linkage on driver side in second set of factory running board holes from front. Use flange bolts (10) and torque to 22 ft-lbs / 30Nm.

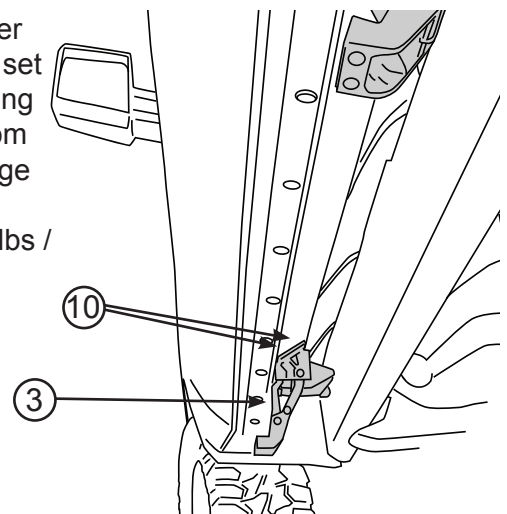

4

Repeat linkage installation on passenger side.

Install idler linkage in last set of factory running board holes from rear. Use flange bolts (10) and torque to 22 ft-lbs / 30Nm.

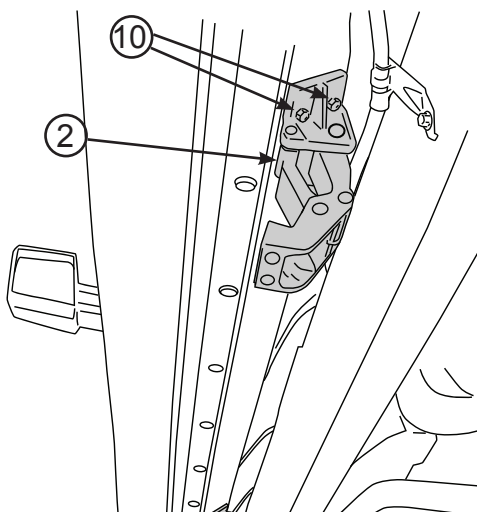

5

Repeat linkage installation on passenger side.

Install running board. See step 7 for alignment.

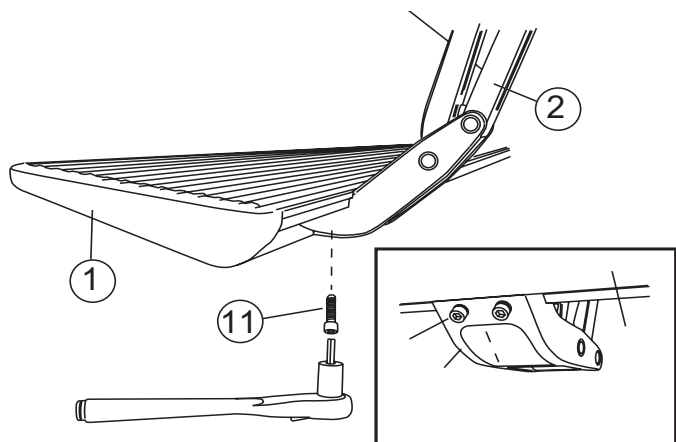

6

Running board alignment.

Tundra:

Slide mounting T-nut into position. Align rear of running board with back edge of rear door.

Sequoia:

Slide mounting T-nut into position. Align rear of running board to the back edge of the cab.

Mount running board and tighten fasteners to 10 ft-lbs / 14Nm. Insure linkages are squared to body prior to torquing fasteners.

7

Install controller under hood on driver side fender apron. Secure to factory wiring loom with 11" cable ties.

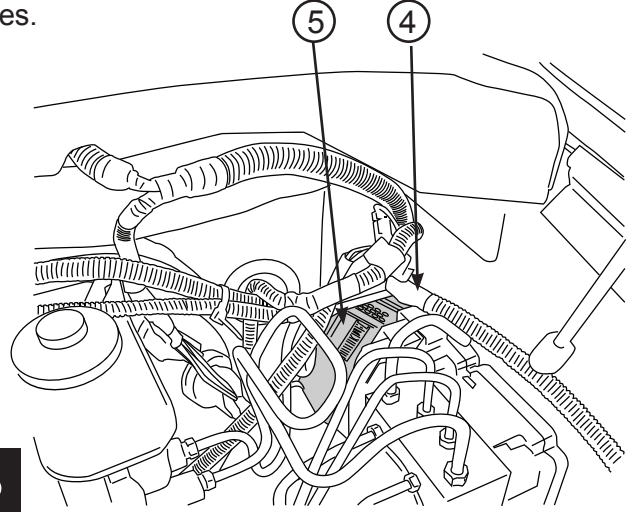

8

Remove power fuse. Connect wire harness to controller and secure locking clip. Connect red power lead to positive battery terminal and black ground lead to grounding lug on fender apron.

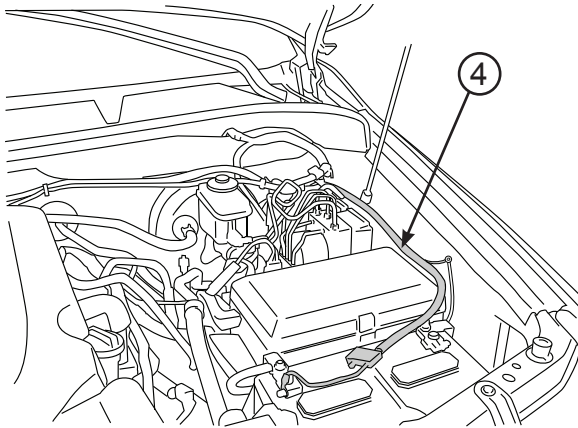

9

Route longest leg of wire harness across fire wall to passenger side and under vehicle outside of frame rail.

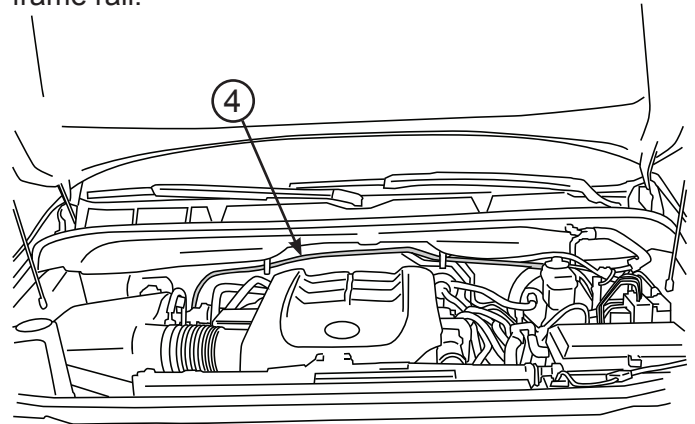

10

Route shorter leg of wire harness down driver side fender well and under vehicle outside of frame rail.

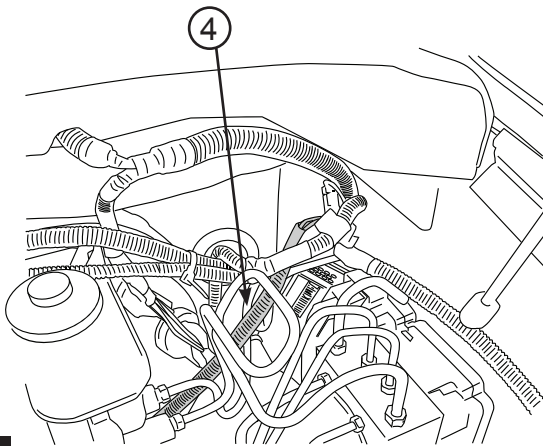

11

Remove driver and passenger front sill plates and kick panels. Pull up carpet. Locate rubber grommets under carpet in forward floorboards. Cut a slit in the rubber grommets and pass the trigger wires up through grommets under carpet on both the driver and passenger side..

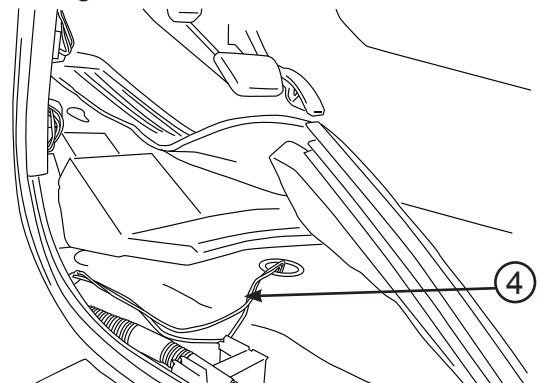

12

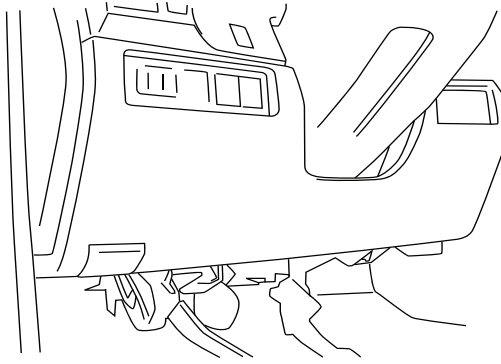

Remove trim panel below steering column

13

Posi-Tap™ instructions

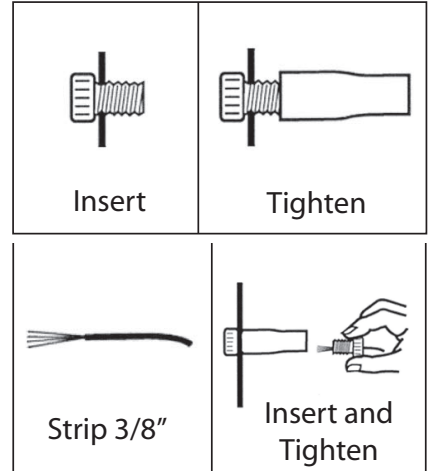

14

2007 - 2017 model years: Locate main electrical junction box located under dash to the left of the steering column. Connect grey Power Step wire to 18 gage black or dark charcoal wire (*Driver Rear*) in pin 2 of upper left connector shown.

2018 model years: Locate the 18 gage pink w/red stripe wire (*Driver Rear*) in Pin 24.

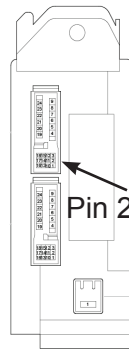
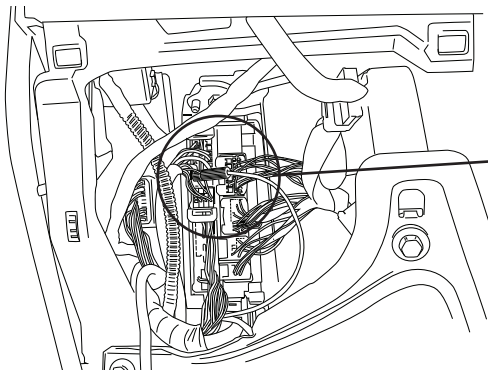

2007 - 2017 Model Years

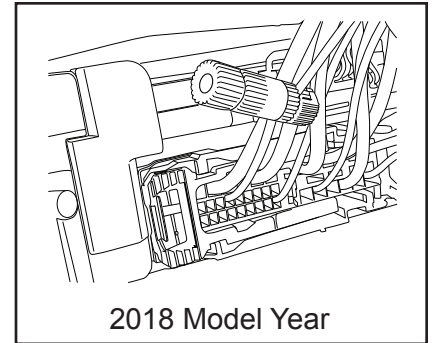

2018 Model Year

15

Locate 20 pin connector at bottom of panel on left. Connect blue Power Step wire to 18 gage blue wire (*Driver Front*) in pin 15 of connector shown. Plugs are located to the left of E Brake Pedal.

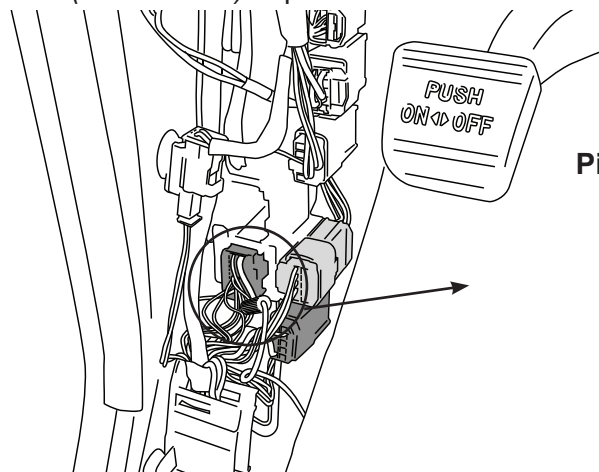

Pin 15

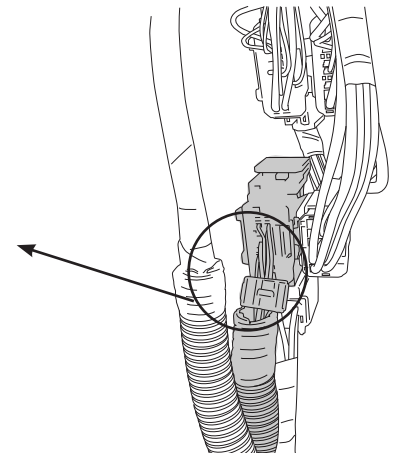
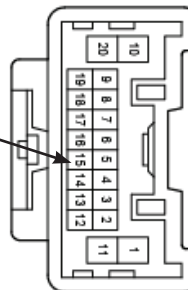

16

2007-2013 Model Years

2014 - 2018 Model Years

Locate the 22 pin connector at the bottom of the passenger side kick panel area. See pin connector locations for corresponding model years.

(07-13 Model yrs) plug color Grey Pin 1 (Passenger Rear) wire color will be Blue and pin 9 (Passenger Front) wire will be White.

(2014-17 Model yrs) plug color white Pin 3 (Passenger Rear) wire color will be Tan and pin 10 (Passenger Front) wire will be Green.

(2018 Model yrs) plug color white Pin 3 (Passenger Rear) wire color will be Tan and pin 22 (Passenger Front) wire will be Green.

2007-2013 Model Years

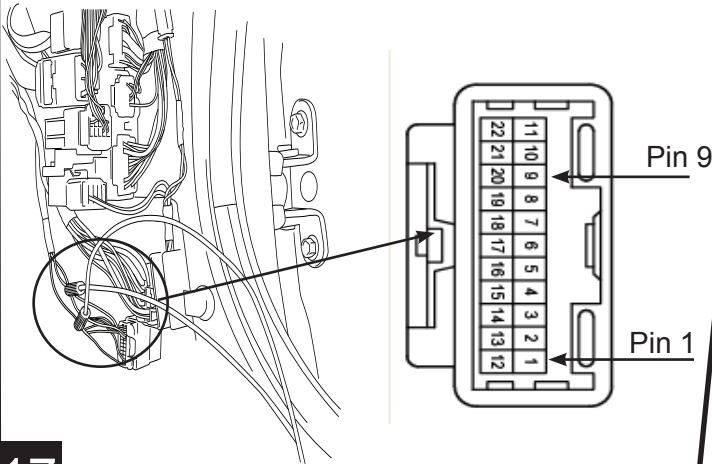

2014-18 Model Years

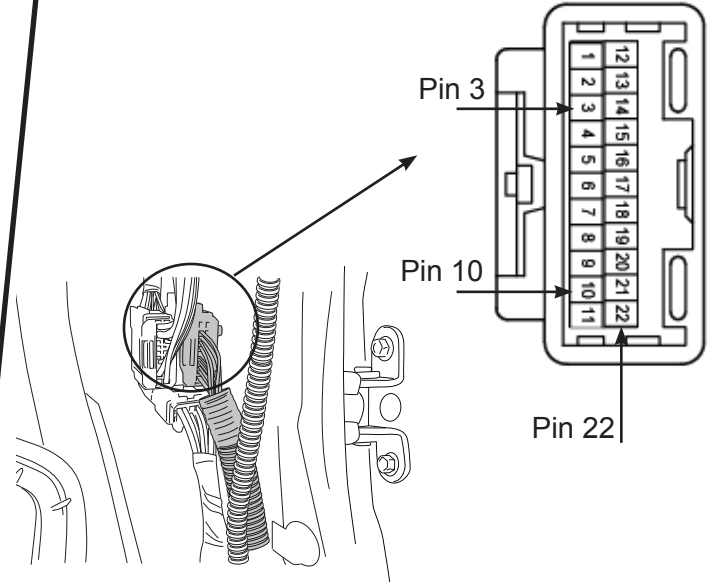

17

Insert plug from wire harness onto motor.

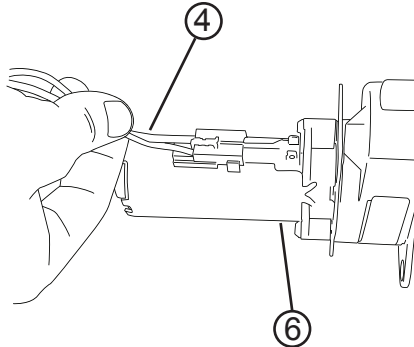

18

Slide rubber grommet on wire harness into slot of motor cover. Install motor cover onto motor.

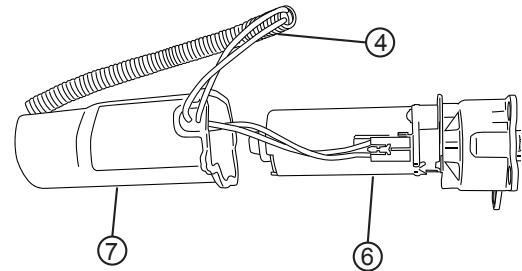

19

Partially separate the plastic rivet from the pin by bending the pin back and forth. Slide motor cover over motor and insert plastic push pin rivets in mounting holes of motor cover. Drive pin flush with rivet head. Use pliers to ease installation.

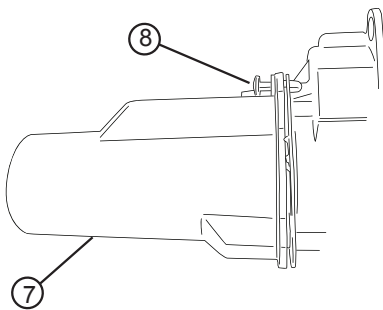

20

On each side of the vehicle measure from the front edge of door line on the pinch weld to the specified lengths below. Measure at 21" for front LED Light and 69" for rear LED Light.

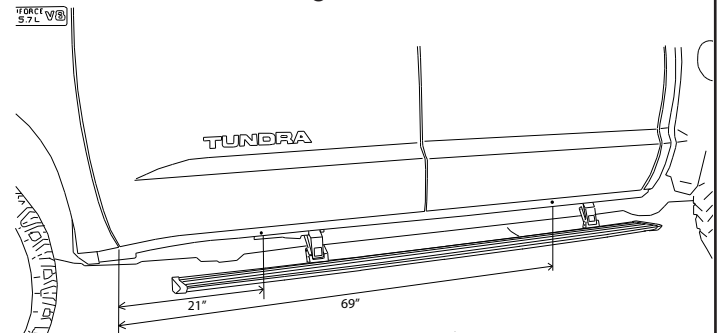

21

Drill a 9/32" hole through the pinch weld at marked locations. Debur all holes.

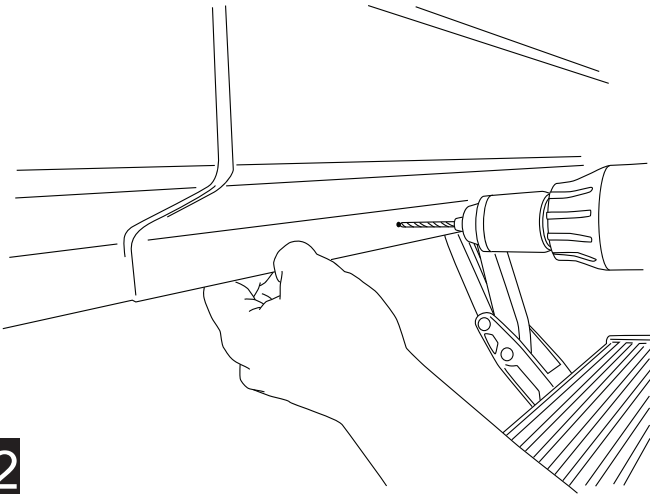

22

Insert grommet into drilled holes. Insert lamp wires through the grommets. (Silicon lube will help wires slip through grommets.)

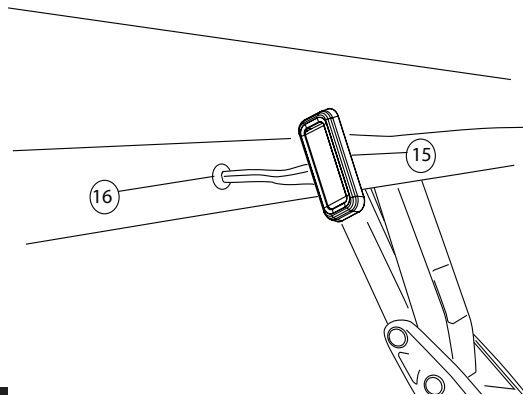

23

Affix lamp through rocker panel surface. Make sure lamp is affixed to a flat, clean surface.

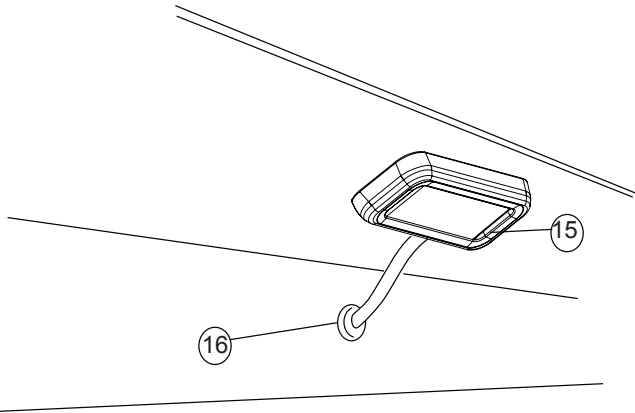

24

Using supplied butt connectors, connect the lamp wires. Red to Red, Black to Black. Once Crimped use heat gun to shrink tube.

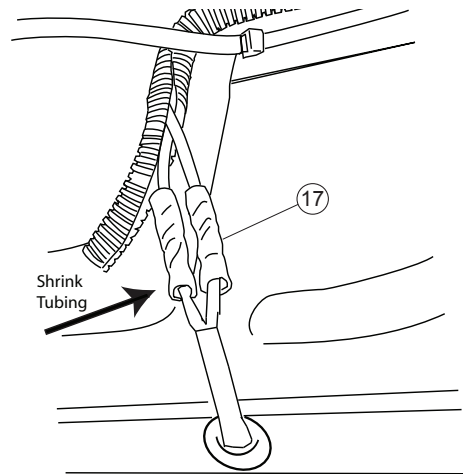

25

Close and wrap with conduit and electrical tape. Secure all loose wires with cable ties, with lamp wires pulled upward to avoid any wire snagging.

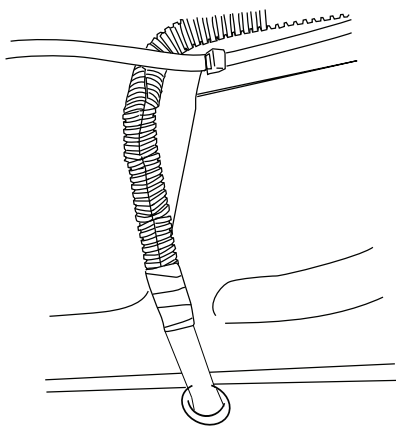

26

Reinstall fuse.

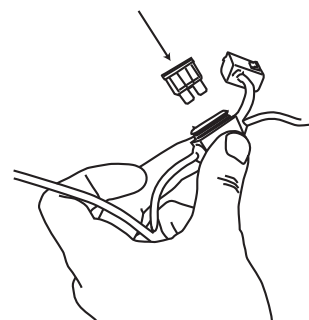

27

Check that all doors activate the Power Step and the LED Lights work when doors open and close. Reinstall any remaining trim panels.

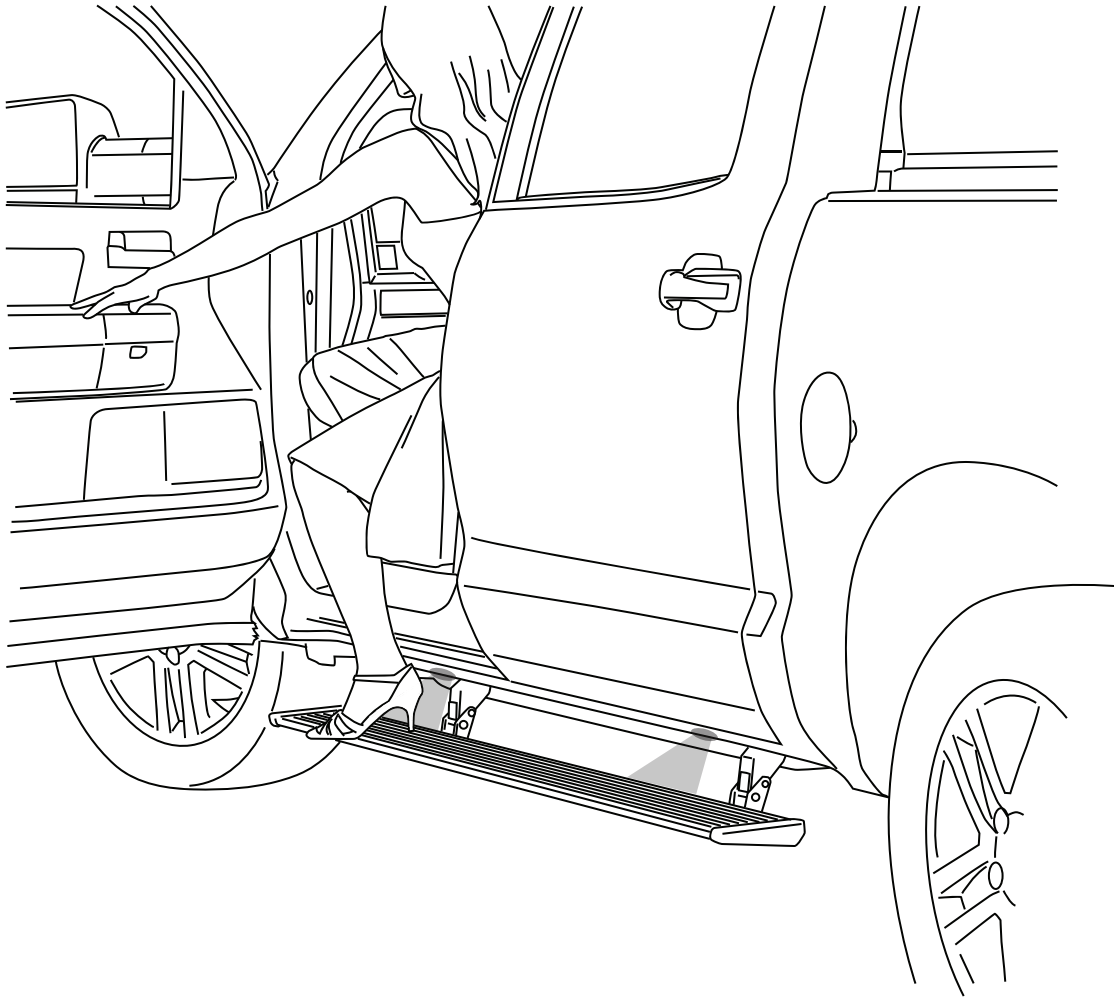

FINAL SYSTEM CHECK

Check that all doors activate the PowerStep and the LED lights work when doors open and close.

NORMAL OPERATION: When the doors open, PowerStep automatically deploys from under the vehicle. When the doors are closed, PowerStep will automatically return to the stowed/retracted position. ***Note that there is a 2-second delay before the PowerStep returns to the stowed/retracted position.***

CORRECT OPERATION OF LIGHTS: All four lamps will illuminate upon opening any door of vehicle. Lamps will stay on until restowing of both Power Steps or until 5 minutes has expired with the doors open. When the lights timeout after 5 minutes, they can be reilluminated by closing and opening any door of vehicle.

POWER-DEPLOYABLE RUNNING BOARDS OPERATION: AMP Research PowerStep running boards automatically move when the doors are opened to assist entering and exiting the vehicle.



Automatic power deploy:

The running boards will extend down and out when the doors are opened.

Automatic power stow:

The running boards will return to the stowed position when the doors are closed. There will be a 2-second delay before the running boards move to the stowed position.

Automatic stop:

If an object is in the way of the moving running board, the running board will automatically stop. To reset, clear any obstruction, then simply open and close the door to resume normal operation.



Manually set in the deployed (OUT) position for access to the roof:

The running boards can be manually set in the deployed position by firmly holding the step down with your foot while at the same time closing the door. To resume normal operation, open and close the door.

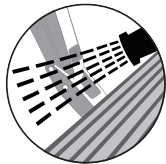

Maintenance: In adverse conditions, debris such as mud, dirt, and salt may become trapped in the running board mechanism, possibly leading to unwanted noise. If this occurs, manually set the running boards to the deployed position and flush the front and rear hinge arms with a high-pressure car wash wand.

Avoid spraying the motors directly. After washing, apply silicone spray lubricant to the hinge pivot pins. Do not apply silicone, wax or protectants like Armor All® to the running board stepping surface.

Caution! Keep hands away when the running board is in motion.

5-YEAR LIMITED WARRANTY

AMP RESEARCH warrants this product to be free from defects in material and workmanship for FIVE (5) YEARS FROM DATE OF PURCHASE, provided there has been normal use and proper maintenance. This warranty applies to the original purchaser only. All remedies under this warranty are limited to the repair replacement of the product itself, or the repair or replacement of any component part thereof, found by the factory to be defective within the time period specified. The decision to repair or replace is wholly within the discretion of the manufacturer.

This warranty specifically excludes labor. If you have a warranty claim, first you must call our factory at the number below for instructions. You must retain proof of purchase and submit a copy with any items returned for warranty work. Upon completion of warranty work, if any, we will return the repaired or replaced item or items to you freight prepaid. Damage to our products caused by accidents, fire, vandalism, negligence, misinstallation, misuse, Acts of God, or by defective parts not manufactured by us, is not covered under this warranty.

ANY IMPLIED WARRANTIES OF MERCHANTABILITY AND/OR FITNESS FOR A PARTICULAR PURPOSE CREATED HEREBY ARE LIMITED IN DURATION TO THE SAME DURATION AND SCOPE AS THE EXPRESS WRITTEN WARRANTY. OUR COMPANY SHALL NOT BE LIABLE FOR ANY INCIDENTAL OR CONSEQUENTIAL DAMAGE.

Some states do not allow limitations on how long an implied warranty lasts, or the exclusion or limitation of incidental or consequential damages, so the above limitations or exclusions may not apply to you. This warranty gives you specific legal rights, and you may also have other rights that vary from state to state.

FOR WARRANTY ISSUES WITH THIS PRODUCT PLEASE CALL AMP RESEARCH CUSTOMER SERVICE 1-888-983-2204

WARNING

Be sure to read and precisely follow the provided instructions when installing this product. Failure to do so could place the vehicle occupants in a potentially dangerous situation. After installing or reinstalling, re-check to insure that the product is properly installed.