



## Installation Instructions: MG3/MG4

# CHEVY COLORADO/GMC CANYON 5'2" or 6'2" BED LENGTH

**NOTE:** Most of the images in these instructions are of the short bed, but they apply to both length beds

2015-CURRENT

## TOOLS REQUIRED

- #2 Phillips screwdriver
- Short 7/32" hex wrench
- 7/16" deep socket
- 3/8" socket
- Electric drill
- 9/64" drill bit
- Drill stop
- 1/8" Allen wrench

Watch short installation videos at [www.decked.com/video](http://www.decked.com/video) | Register your system at [www.decked.com/warranty](http://www.decked.com/warranty)

FOLLOW US:



@DECKEDUSA | #DECKEDUSA

VERSION 5

DECKED.COM | 208.806.0251

RC240

# CONTENTS

## DECKED carton

- LEFT DECK HALF - 1
- RIGHT DECK HALF - 1
- CENTER VERT - 1
- CABSIDE VERT - 1
- DRAWER - 2
- LEFT AMMO CAN - 1
- RIGHT AMMO CAN - 1
- LEFT STUD - 1
- RIGHT STUD - 1
- AMMO CAN LID - 2
- C-CHANNEL - 2
- RULER - 1
- HARDWARE BOX - 1
- TORSION BRACE - 1
- BOTTLE OPENER - 1

## Hardware box - unbagged components

(inside DECKED carton):



## HARDWARE box - bagged components

- PREP-MG3\_MG4 - 1
- S1 - 1
- S2 - 1
- N1 - 1
- J5 - 2
- DRAWER 1 - 1
- DRAWER 2 - 1
- WHEELS - 1
- FINAL MID - 1
- PREP-EXTRA - 1
- WASHERS - 1

## ASSEMBLY OVERVIEW

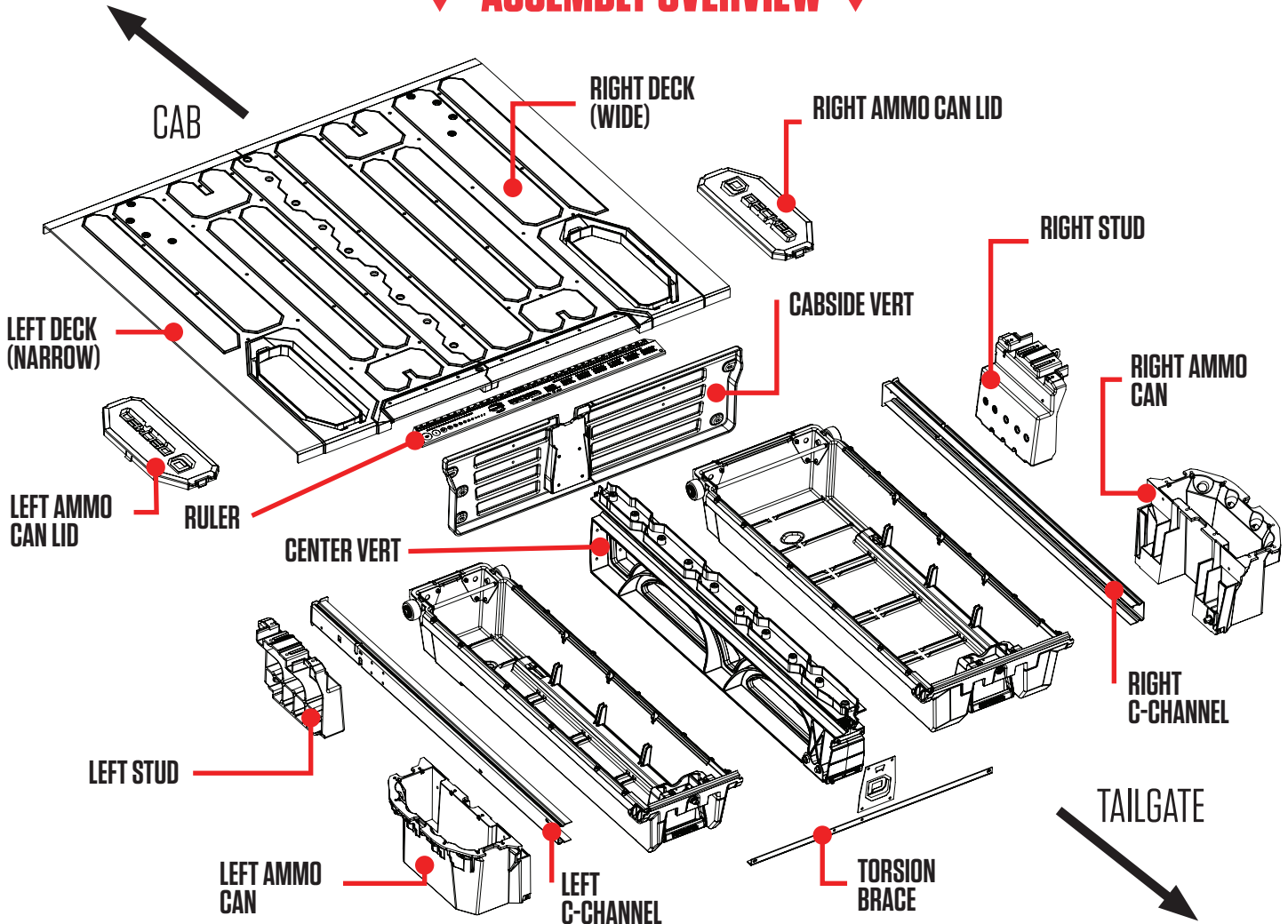

## ▼ HEY! TORQUE BOY: READ BEFORE YOU INSTALL DECKED ▼

1. **DON'T** go rogue on us, please read the instructions.
2. **DON'T** over tighten bolts, get em' hand-tight.
3. **DON'T** use power tools.
4. If you don't follow directions and *do* use power tools:
  - 1). Set clutch at a very low setting. 2). If you blow it, see NOTE.\*
5. Start all bolts with fingers to avoid cross-threading
6. **DON'T** over tighten J-hooks during installation. Make 'em good and snug enough to keep the system from moving in the bed.
7. Nice job if you're still reading.

**NOTE\*** Two extra threaded inserts are included in **BAG PREP-EXTRA**. That's all you get. The inserts will replace any stripped inserts in the tailgate ammo cans, but **NOT THE CENTER VERT**, so hand tighten until snug only! You can also screw the inserts back in if dislocated. There is a straight screwdriver slot on the underside of the insert.

**ALSO:** There will be extra washers left over from the **WASHERS** bag.

*Prevent embarrassing, expletive-filled language,  
watch our detailed installation video or give us a call. We're happy to help!*

208.806.0251 | [DECKED.COM/INSTALLVIDEO](https://DECKED.COM/INSTALLVIDEO)

# PREP BED: MARK CENTER OF BED

- Use a marking pen or wax pencil to mark a centerline (blue) on the raised center bead.

## DETAIL A

MAKE SURE MARK SITS AT LEAST  
14" HIGH (SO YOU CAN SEE IT)

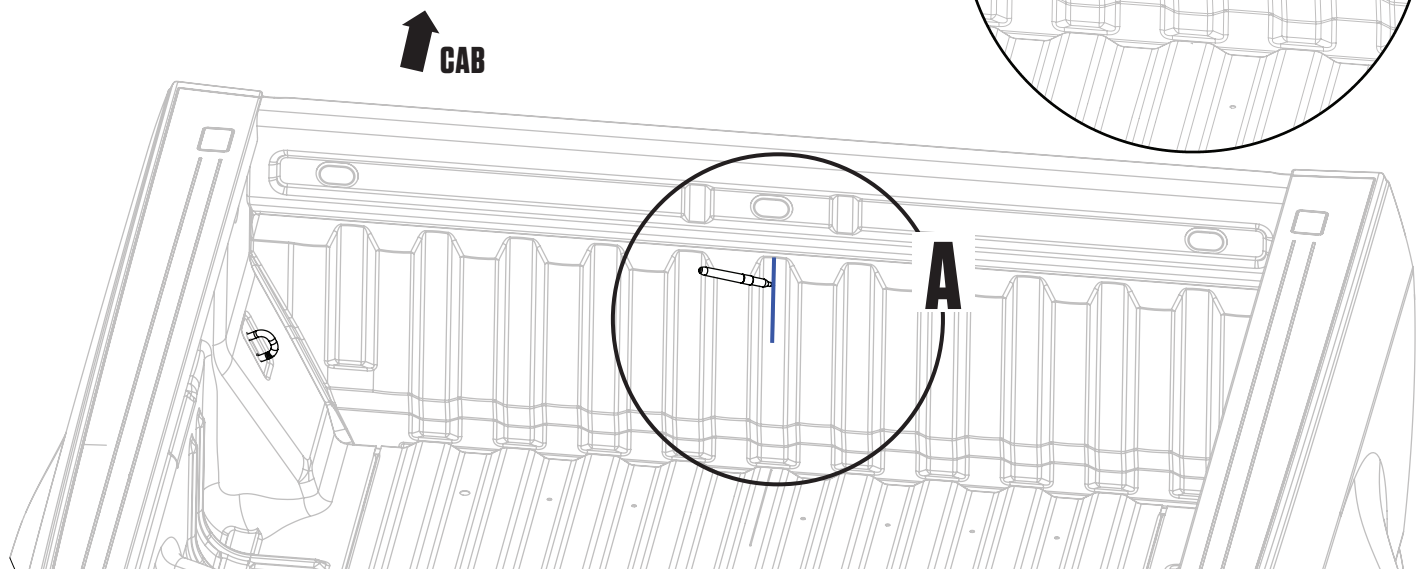
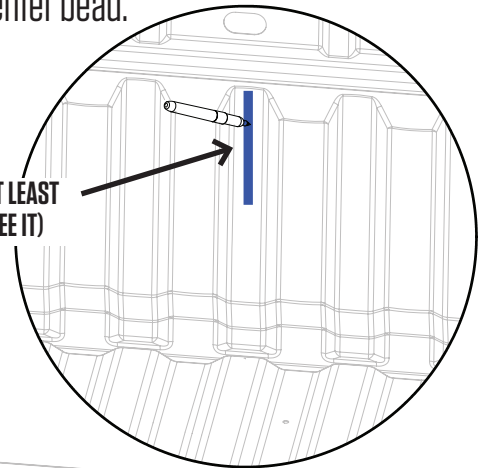

# PREP BED: SHIMS

- **2 SHIMS** can be found in your hardware kit.
- Using the information below:
  - 1) Clean the bed surface where the shims will be located. Isopropyl alcohol (do not drink) is recommended.
  - 2) Remove tape film and apply shim with the strength of 1000 men a.k.a push really hard.

## DETAIL B

Align shim to channel in floor shown. Place shim 7" from rear of bed (red).

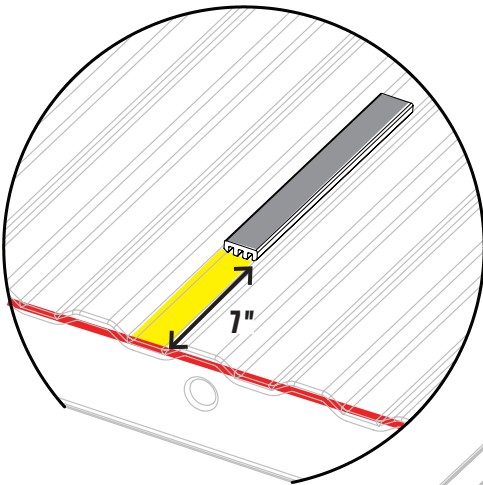

## DETAIL A

Align shim to channel in floor shown 3" from cabside panel of bed (red).

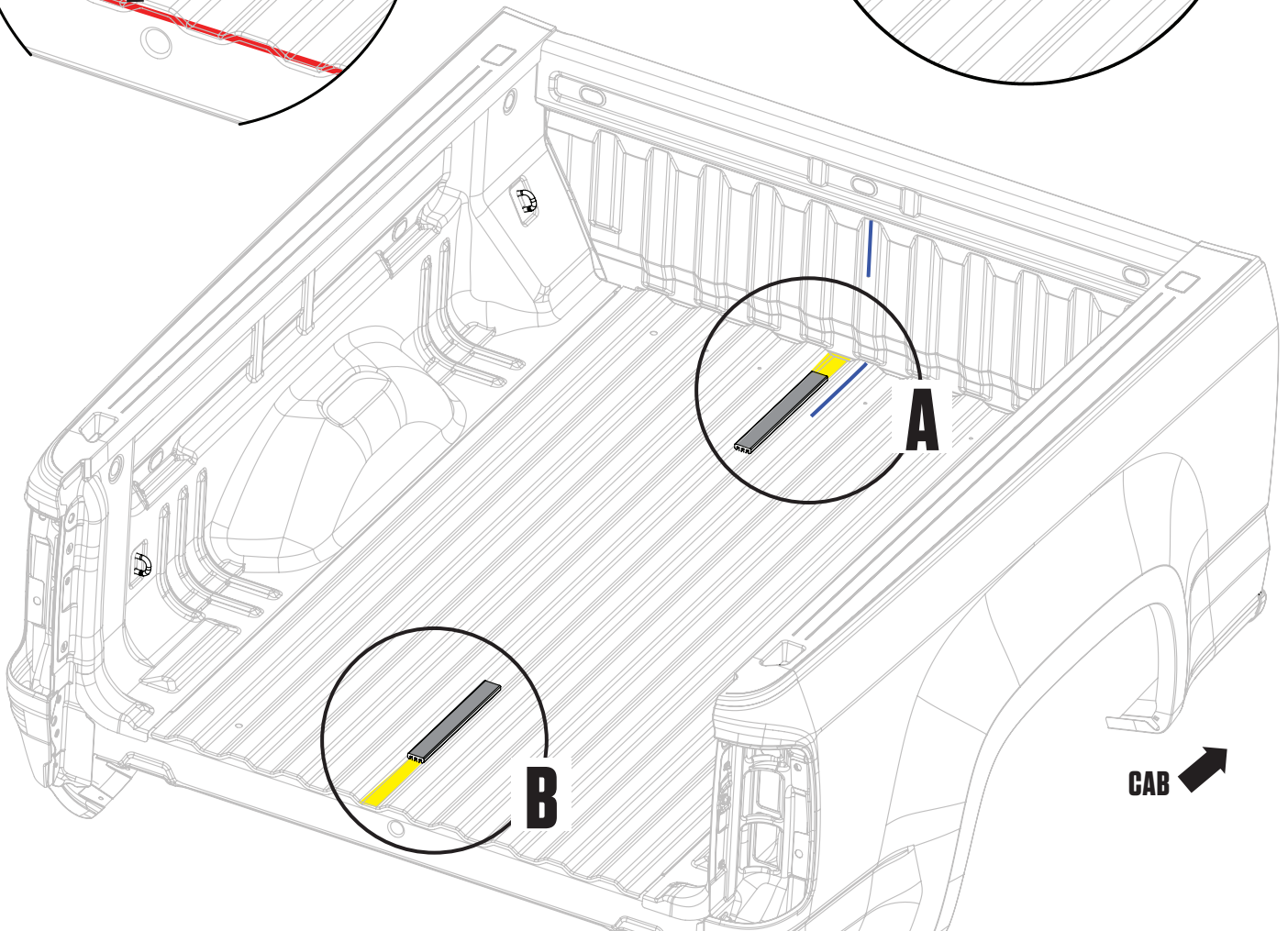
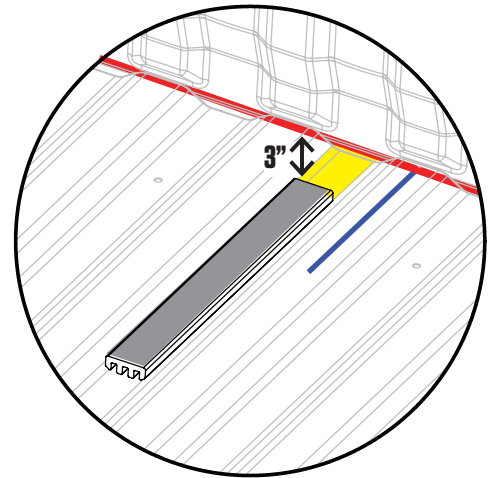

# PREP BED: CABSIDE TIE-DOWNS

**NOTE: If your truck has the embossed logo on the cabside bulkhead, reverse the bracket installation order (flip them). For example, bolt-yellow-green-red-nut.**

- Sandwich the factory driver side tie-down (green) in between the cabside tie-down bracket (yellow) and the clamp plate (red); **BAG PREP-MG3\_MG4**
- Fasten securely through the circular holes with 1" bolt and flanged nut; **BAG PREP-MG3\_MG4**
- Repeat passenger side.

## DETAIL A

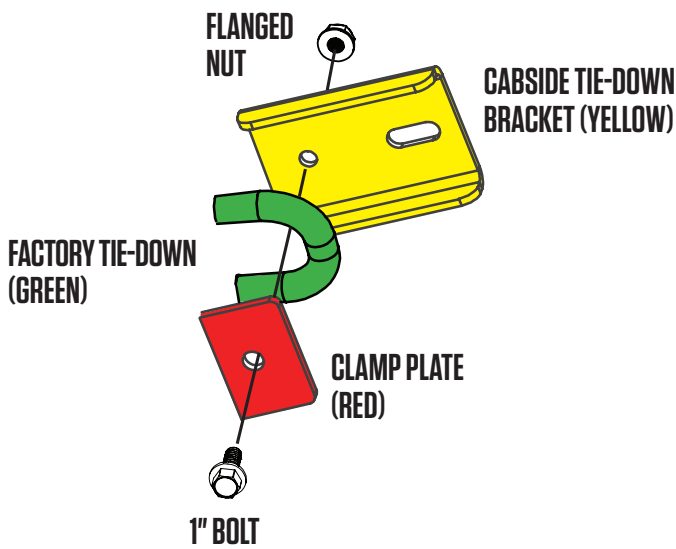

## DETAIL A INSTALLED

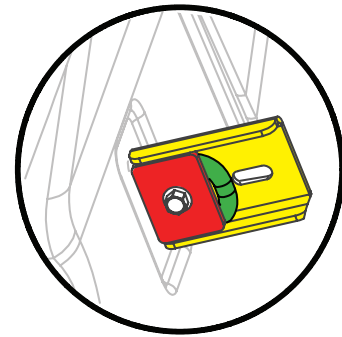

**RECOMMENDED TORQUE:**  
Bolts in labeled bag PREP-MG3\_MG4- 27 in-lb.

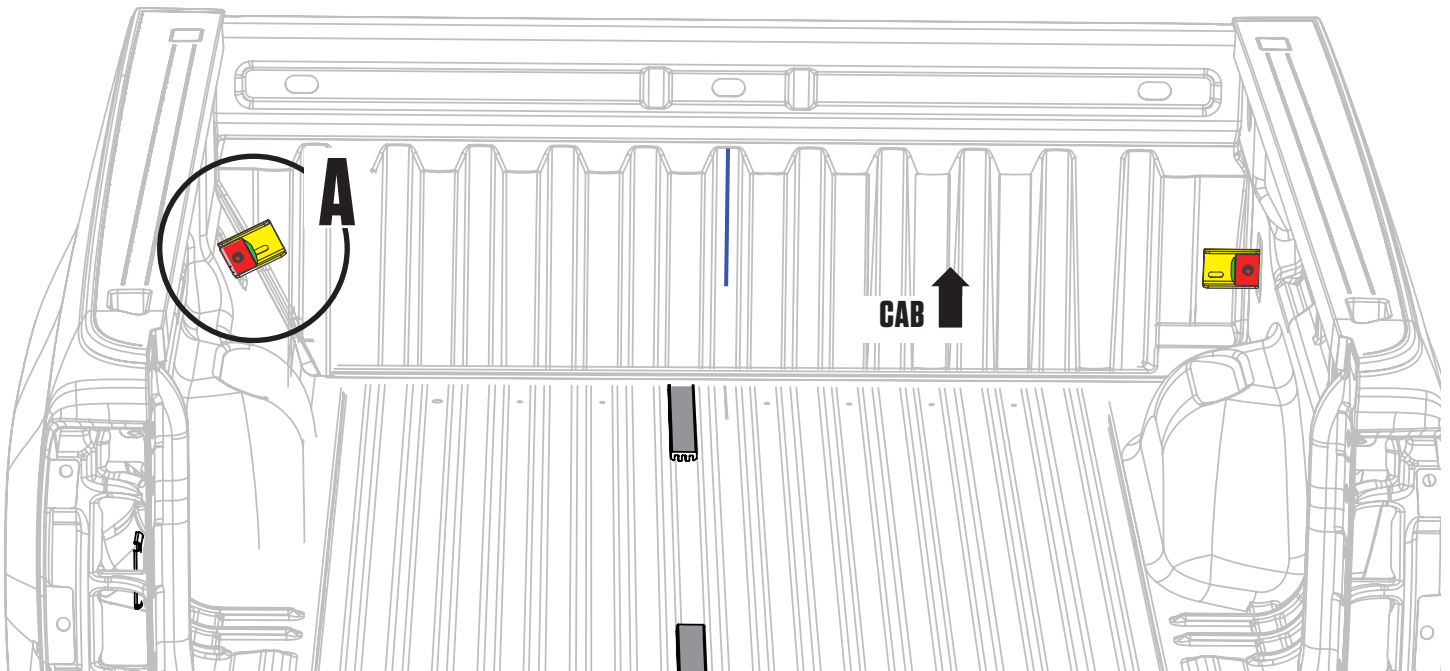

# ASSEMBLY: CENTER VERT + CABSIDE VERT

**NOTE:** Perform the next few steps on a flat surface like a garage floor.

- Attach center vert to cabside vert with four bolts. Alternate to tighten; **BAG S1**.

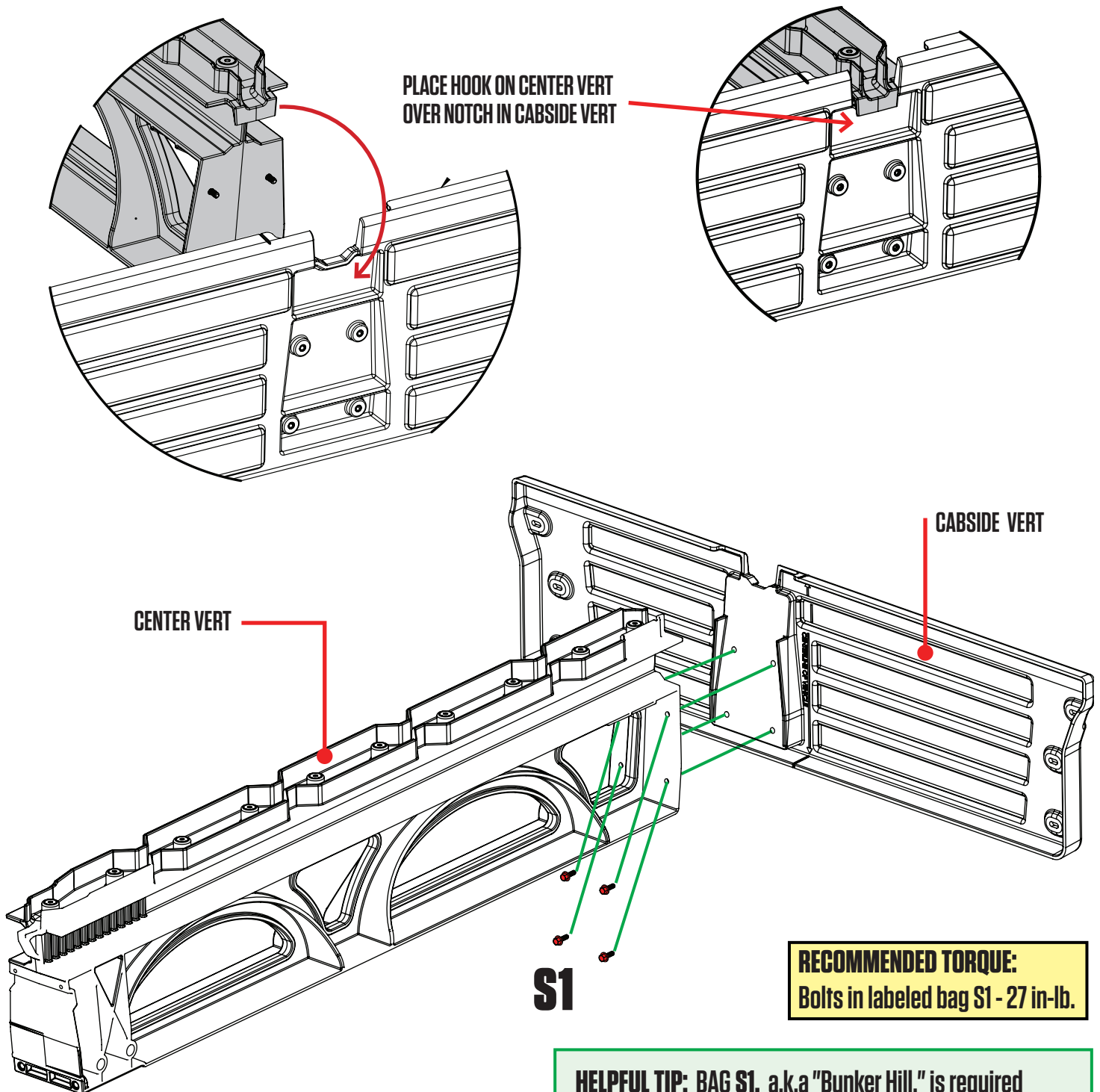

**RECOMMENDED TORQUE:**  
Bolts in labeled bag S1 - 27 in-lb.

**HELPFUL TIP:** BAG S1, a.k.a "Bunker Hill," is required for most of the steps, so keep it close! These bolts are highlighted throughout instructions in **RED**.

# ASSEMBLY: LOOSELY ATTACH STUDS (YUP)

- **LOOSELY** attach studs to cabside vert with six bolts; BAG S1.

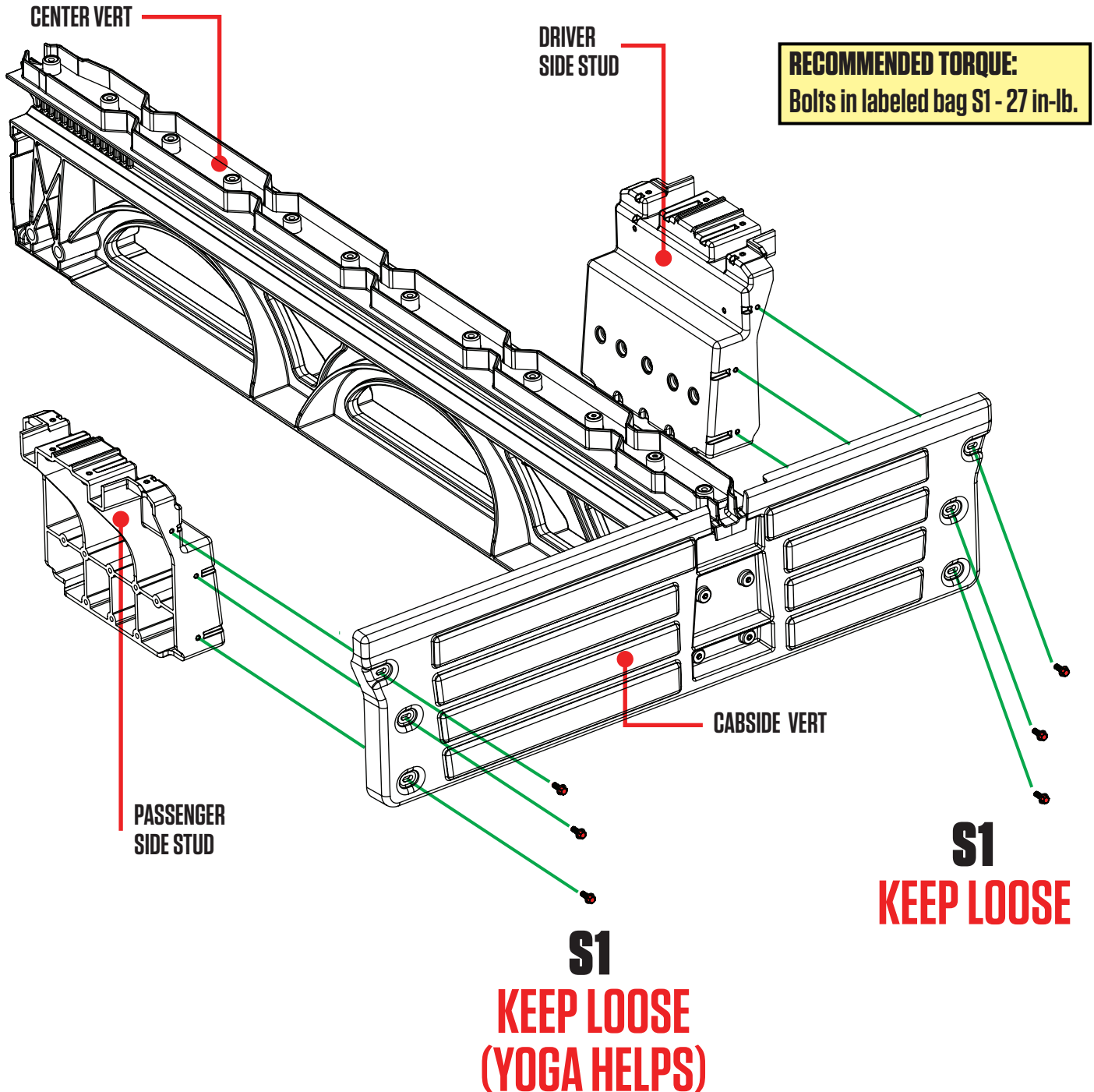

# ASSEMBLY: ALIGN & TIGHTEN STUDS (YUP)

**NOTE:** This step ensures the studs are properly located before tightening bolts. It's important.

- Place ammo cans to support tailgate end of deck panels.
- Lift deck panels on center vert + stud + cabside vert assembly.
- Slide studs around L-R until deck panels are seated.
- **DETAIL A:** Loosely secure four bolts to hold decks onto studs; **BAG S1**.
- Now you can securely tighten the bolts that hold the studs to the cabside vert.
- Unbolt deck from studs, remove deck panels, save bolts, remove ammo cans and set aside for later assembly.

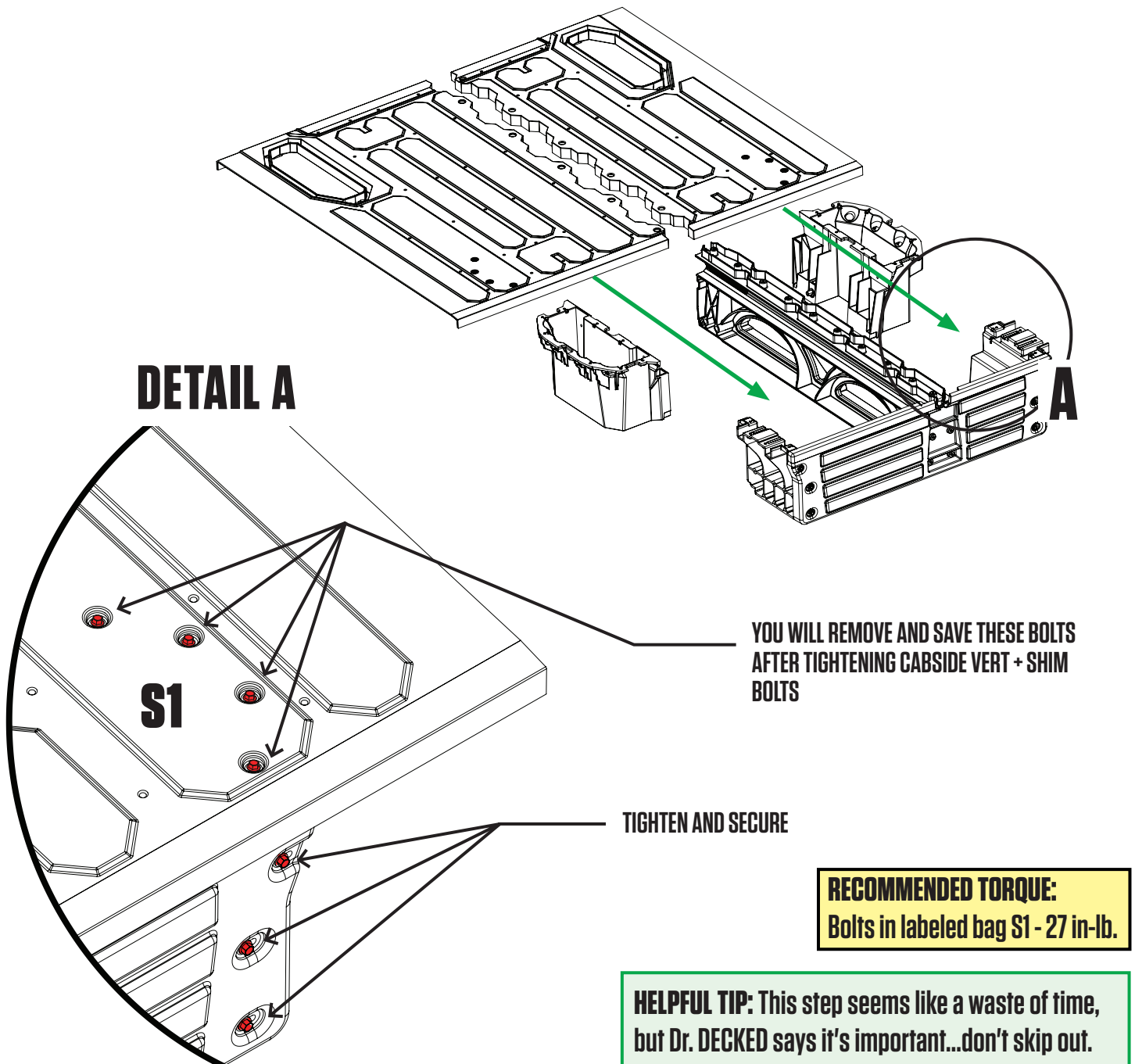



# ASSEMBLY: STUD BRACKETS

- **DETAIL A:** Attach driver side stud bracket to driver side stud using three 3 1/2" bolts and three flanged nuts into proper hole locations (green). Tighten securely; BAG PREP-MG3\_MG4
- **DETAIL B:** Repeat steps in DETAIL A on passenger side.

## DETAIL A

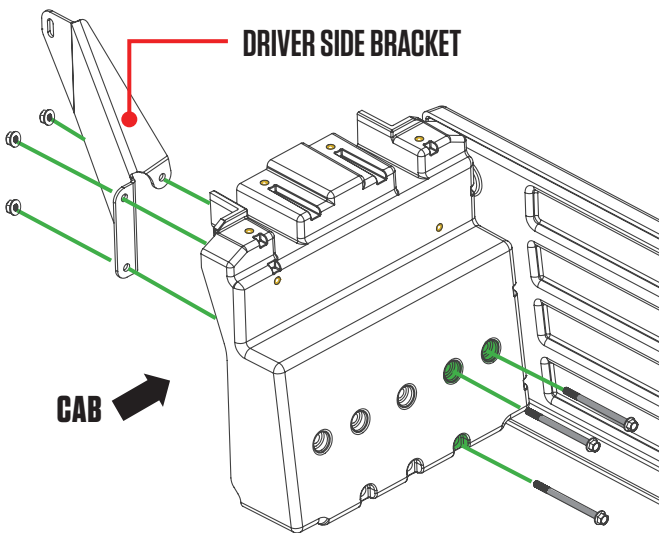

## DETAIL B

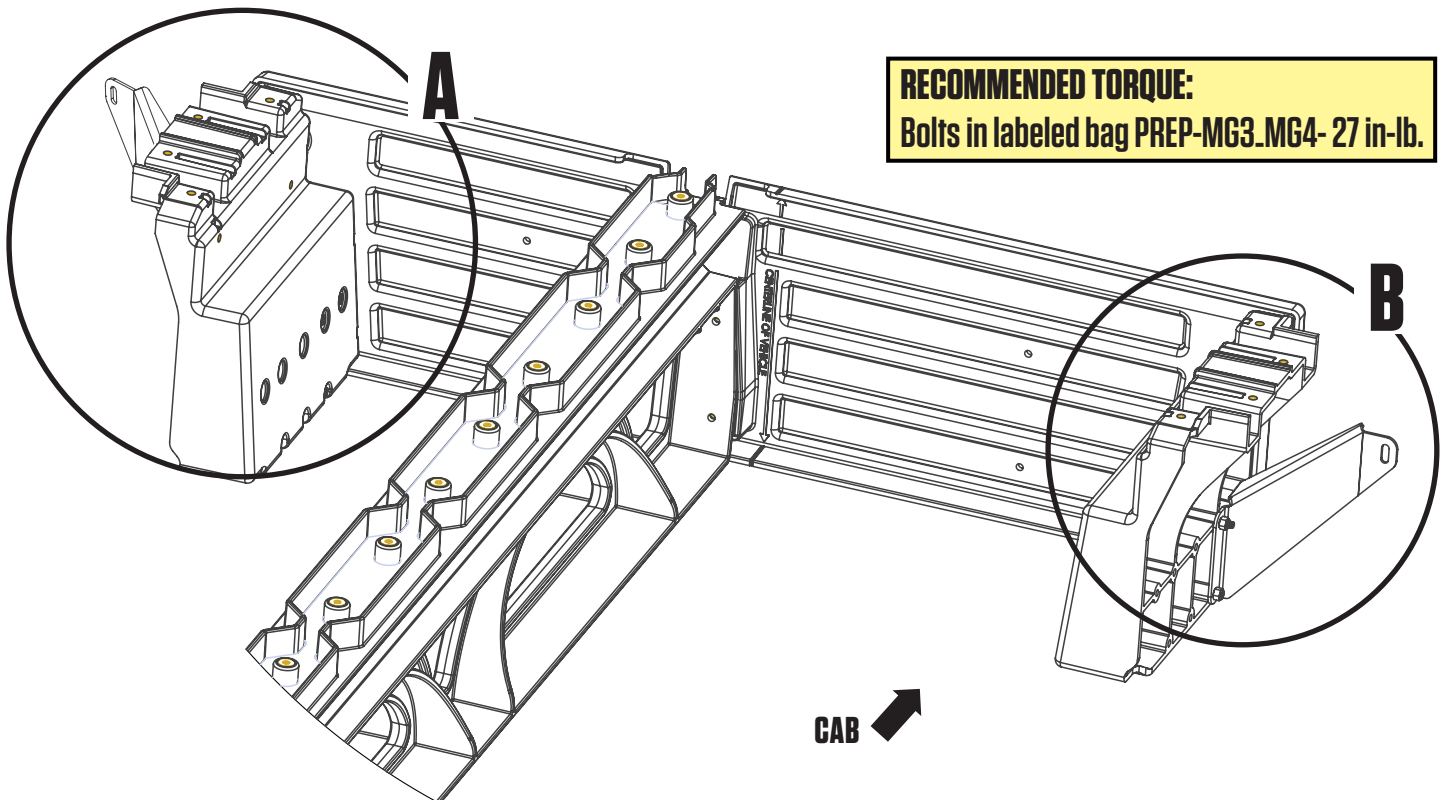
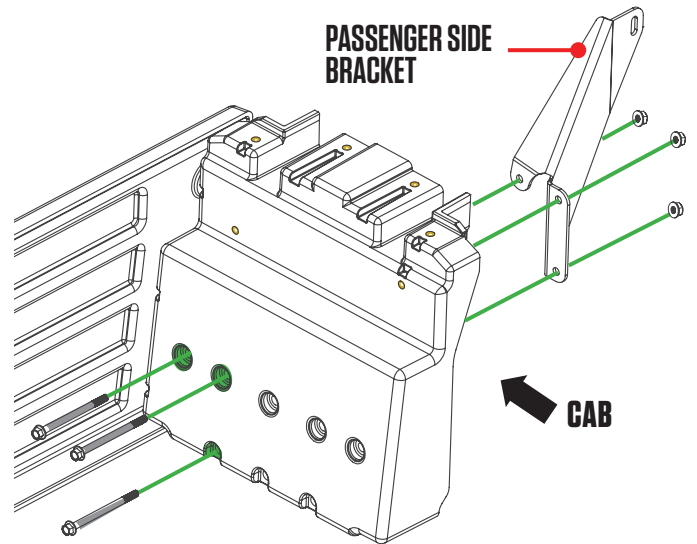

**RECOMMENDED TORQUE:**  
Bolts in labeled bag PREP-MG3\_MG4- 27 in-lb.

# ASSEMBLY: MOUNT ASSEMBLY

- **DETAIL A:** While supporting both ends, lift center vert + stud + cabside vert assembly in truck bed.  
**NOTE: Make sure centerline arrows on cabside vert are aligned with your centerline marks (blue).**
- **DETAIL B:** Place stud brackets cabside of cabside brackets (yellow). Loosely fasten with 3/4" bolt and flanged nut; BAG PREP-MG3\_MG4.
- Repeat passenger side.
- Make sure assembly is still on centerline, then securely tighten both sides.

**RECOMMENDED TORQUE:**  
Bolts in labeled bag PREP-MG3\_MG4- 53 in-lb.

## DETAIL A

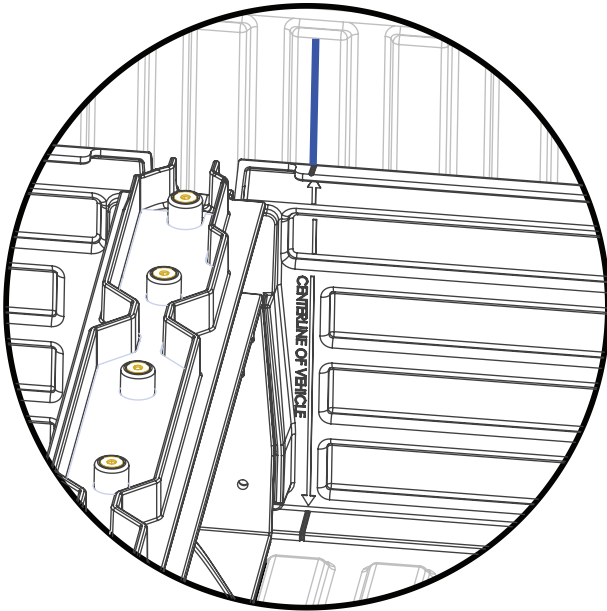

## DETAIL B

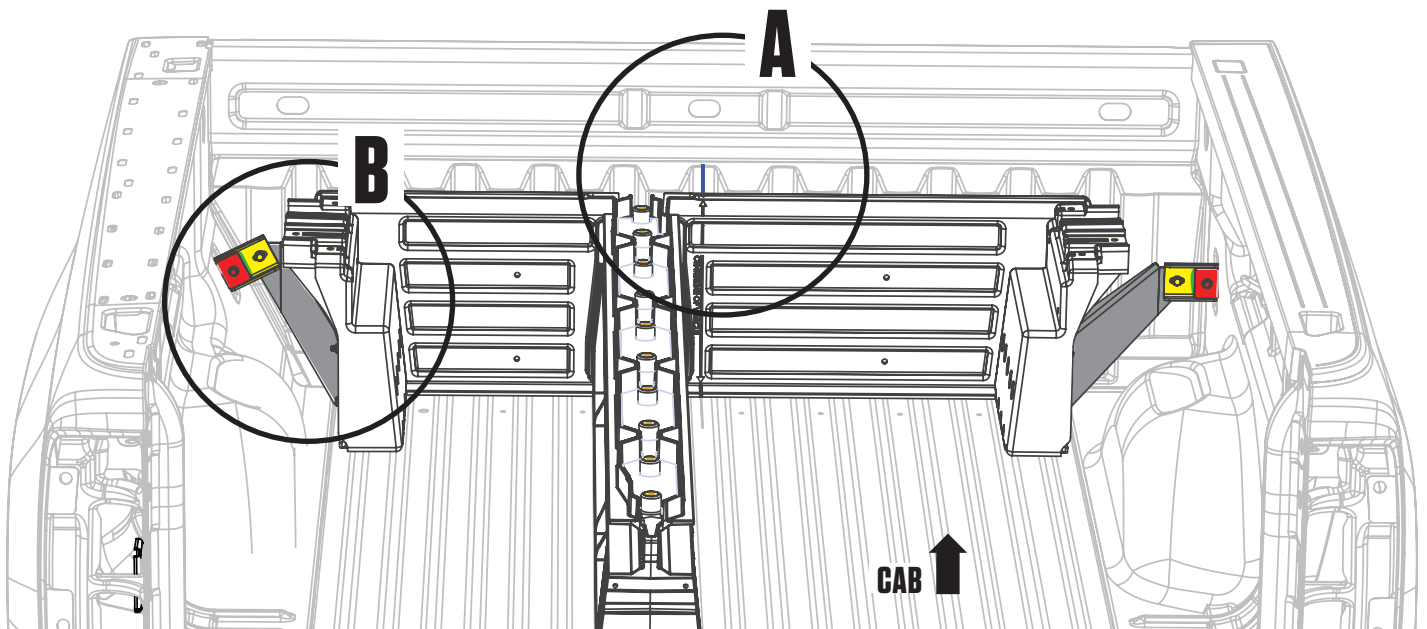
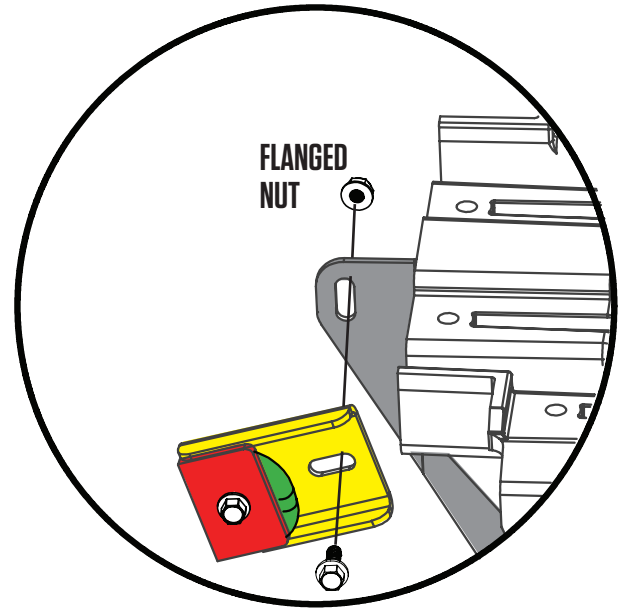

# INSTALL: C-CHANNEL

- Loosely place driver side ammo can at tailgate corner of bed.
- Place driver side C-channel on ledge of stud and ammo can with end plate cabside.
- Install nylon washer only onto 4 S1 bolts and all S2 bolts; **BAG WASHERS**.
- **DETAIL A:** Insert two bolts through C-channel into ammo can and loosely fasten with nut; **BAG S2, BAG N1**.
- **DETAIL B:** Tightly attach C-channel to stud; **BAG S1**.
- Repeat passenger side.

## DETAIL A KEEP LOOSE

**RECOMMENDED TORQUE:**  
Bolts in labeled bag S1 - 27 in-lb.

## DETAIL B TIGHTEN

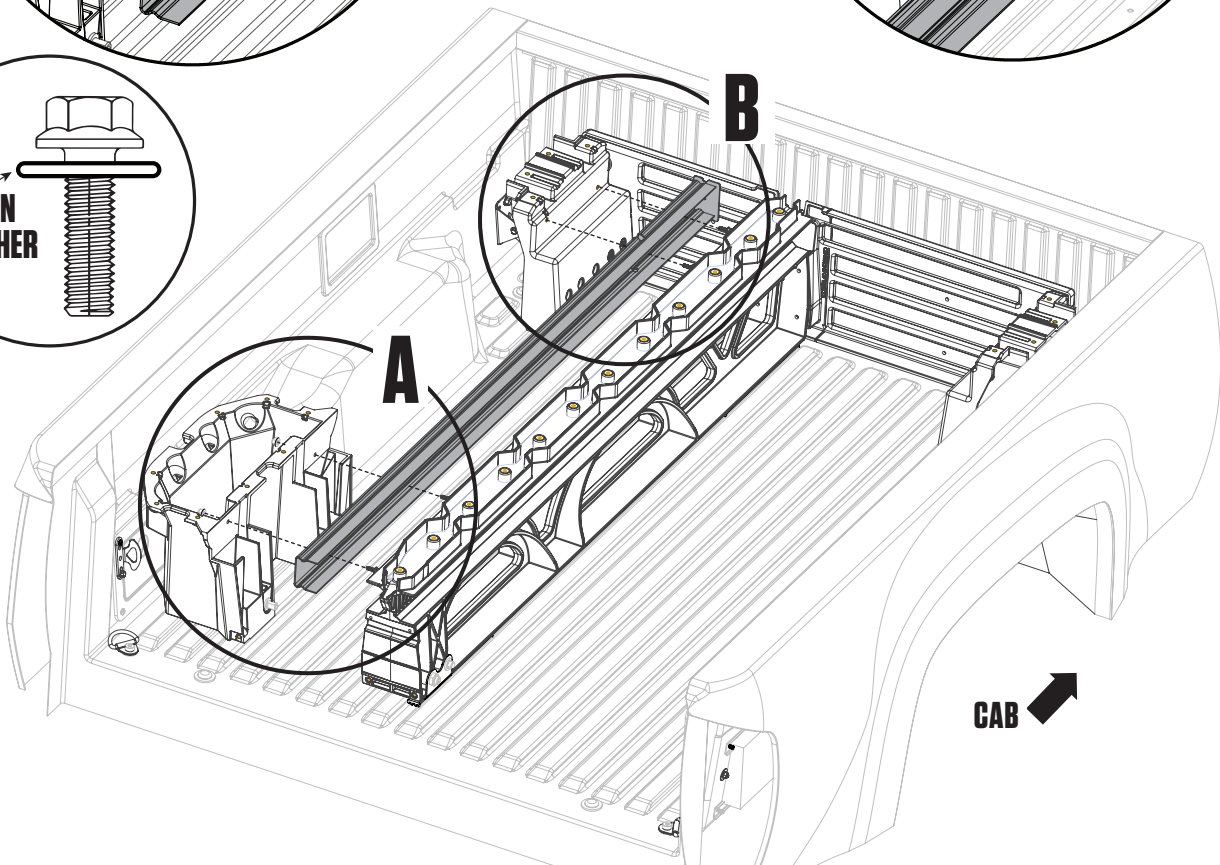
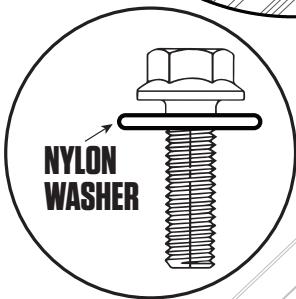
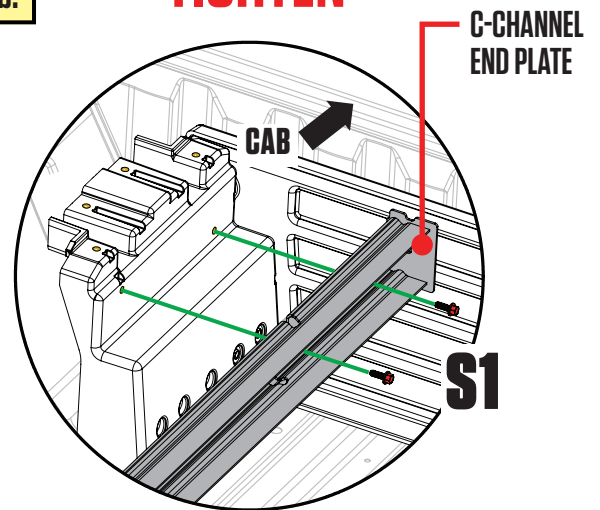
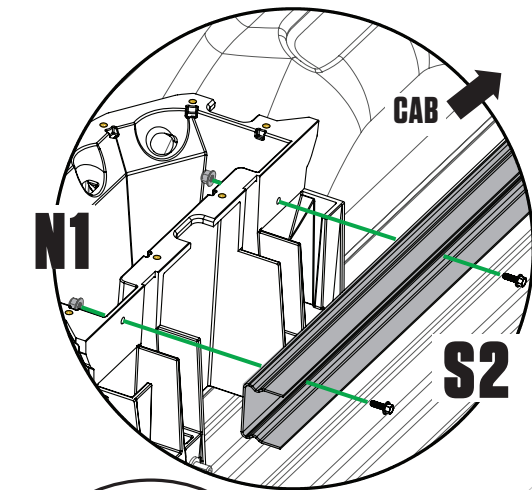

# INSTALL: DECK HALVES

- Loosely place deck panel on side stud, center vert and ammo can.
- Shift ammo can forward, rearward, L-R, as necessary to align with fully seated deck panel.
- Loosely assemble:
  - Five or six bolts (depends on bed length - NO WASHERS) through deck panel into center vert; **BAG S1**.
  - Four bolts with nylon and rubber washers installed as shown through deck panel into stud; **BAG S1, BAG MS WASHERS**.
  - Eight bolts with nylon and rubber washers installed as shown through deck panel into ammo can; **BAG S1, BAG MS WASHERS**.
  - Tighten all **S1** bolts.
  - **Securely tighten C-channel/ammo can nuts and bolts.**
- Repeat other side (**making sure you don't forget to securely tighten C-channel/ammo can nuts and bolts**).
- We have included extra washers - don't worry if you have leftovers.

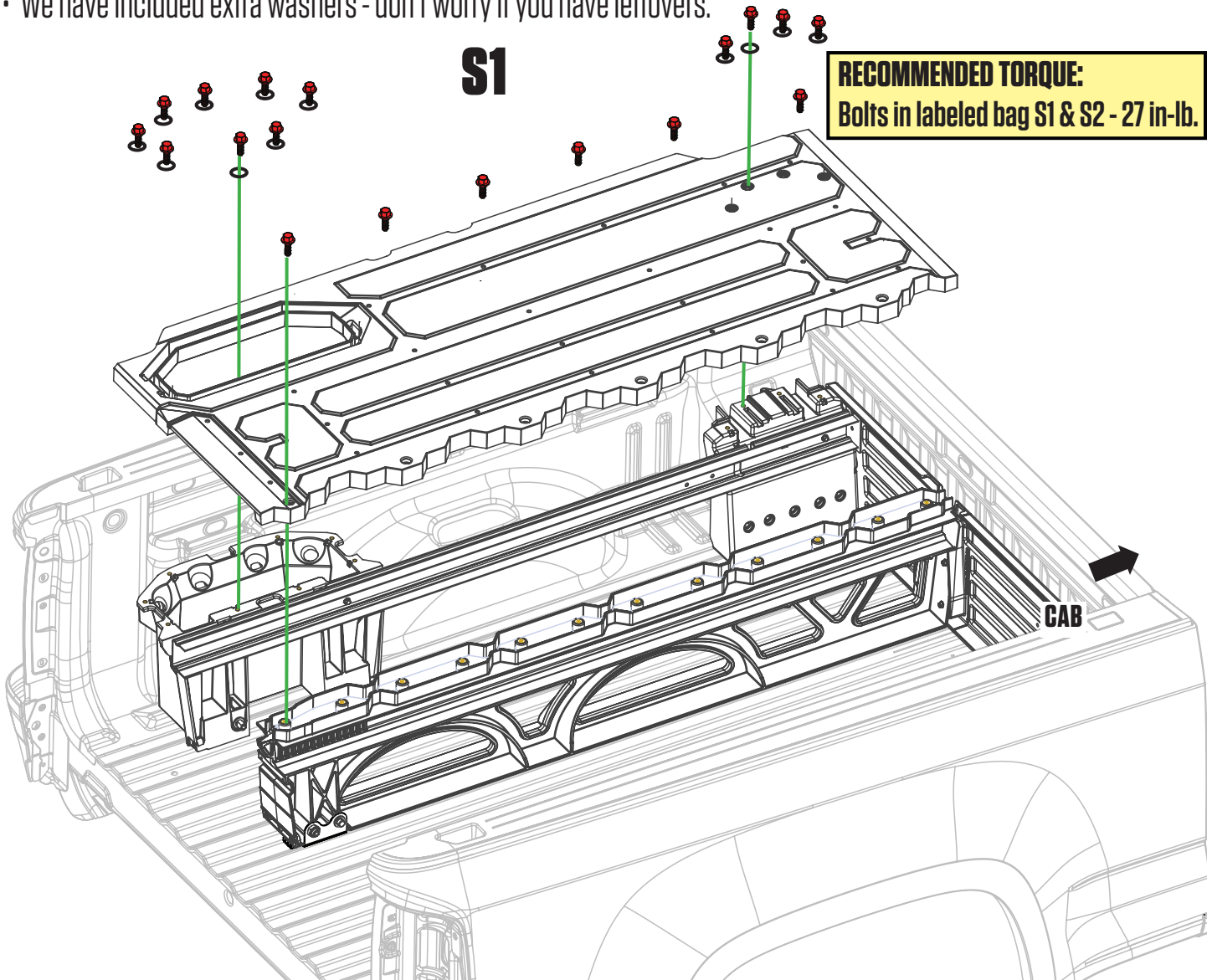

# INSTALL: J-HOOKS

- **Loosely** assemble driver side J-hook assembly in order shown through second closest tailgate side hole in ammo can as shown; **BAG J5**.
- Repeat passenger side.

**DRIVER SIDE AMMO CAN**  
**KEEP LOOSE**

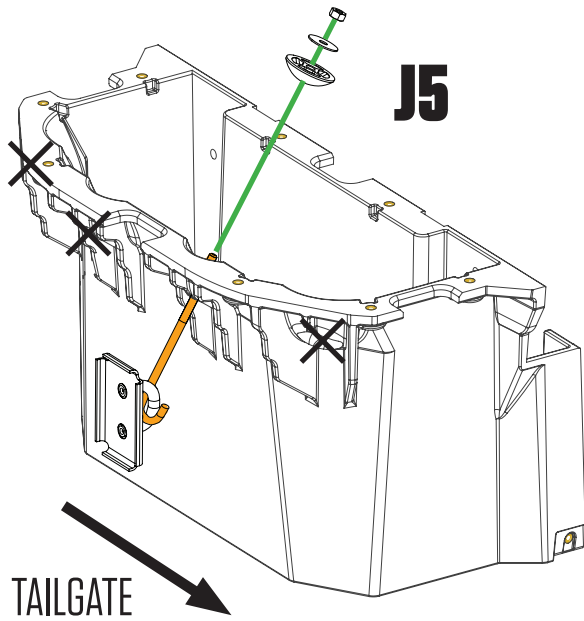

**PASSENGER SIDE AMMO CAN**  
**KEEP LOOSE**

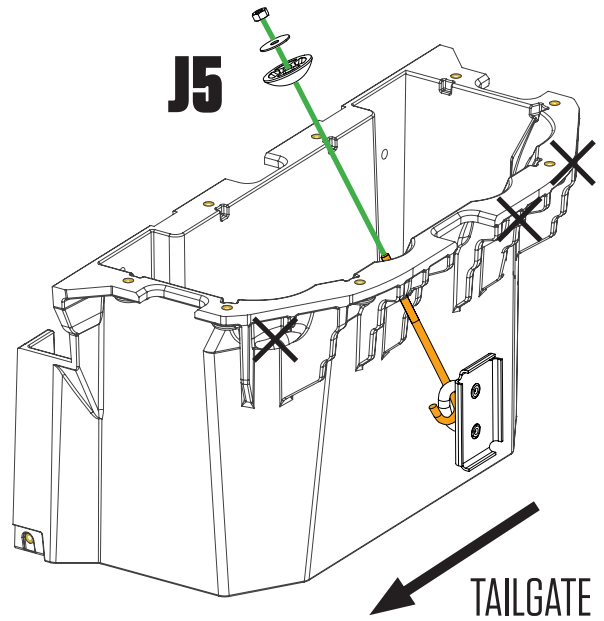

**HELPFUL TIP:** Make sure the hooks  
open toward tailgate.

# DRAWERS: BRACKETS + WHEELS

- Each drawer has a left and a right bracket. Bolt brackets into place via bottom two holes in bracket with 3/4" length bolts. Use the 2" length bolt for the upper cabside wall hole in bracket; **BAG DRAWER 1**.
- Install a tube brace in each drawer with two 3/4" length bolts; **BAG DRAWER 1, BAG DRAWER 2**.
- Attach wheels onto drawer brackets with a 7/32" hex wrench; **BAG WHEELS**

**RECOMMENDED TORQUE:**  
Bolts in labeled bags DRAWER 1 and DRAWER 2 - 27 in-lb.  
Bolts in labeled bag WHEELS - 90 in-lb.

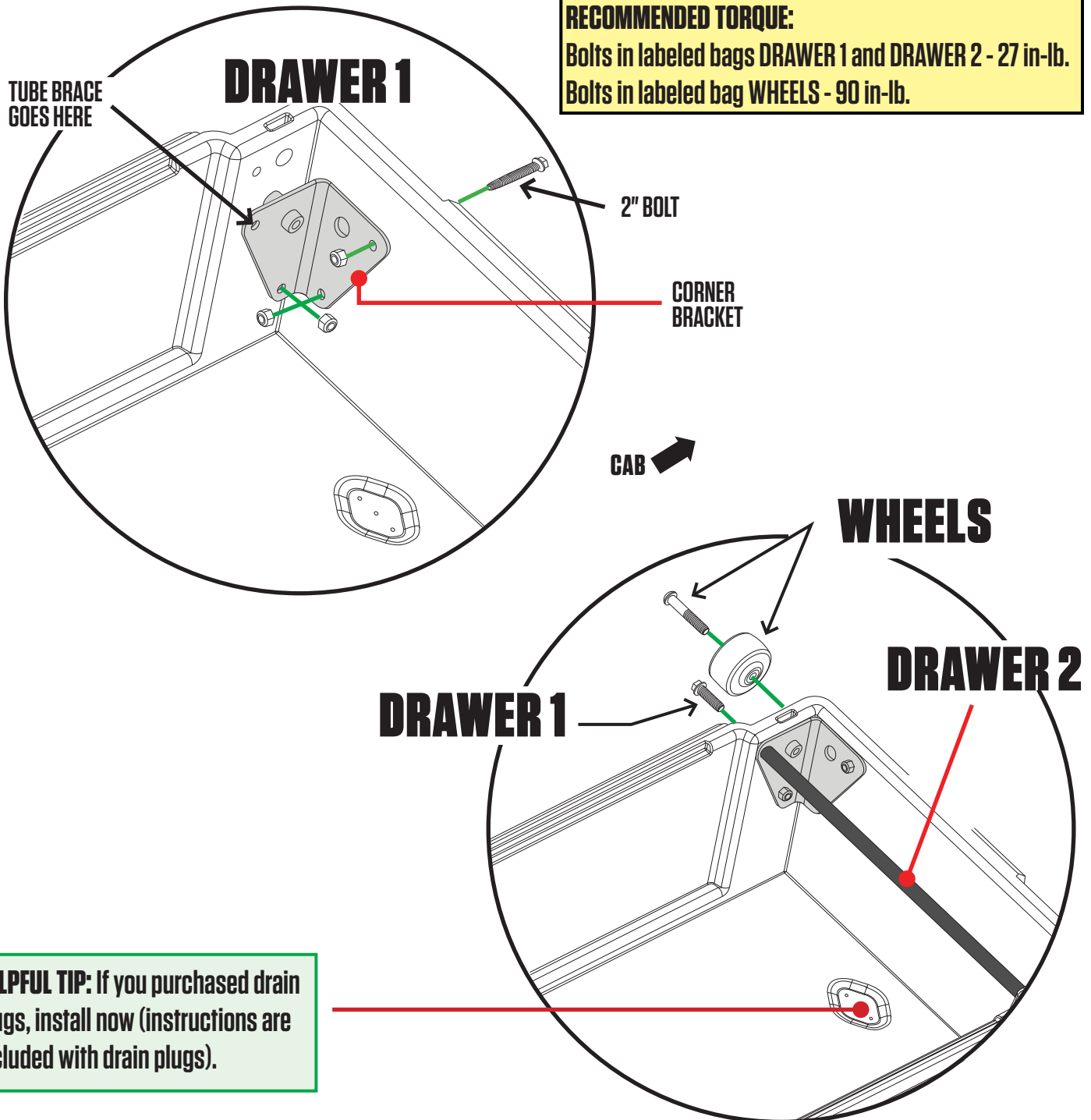

# DRAWERS: AXLE WHEELS + WEATHERSTRIPS

- Slide narrow drawer into driver side drawer cavity. **NOTE: It is easier to fully install narrow drawer first.**
- **DETAIL A:** Install two tailgate wheels onto narrow drawer axles with a 7/32" hex wrench; **BAG WHEELS.**
- Repeat with wide drawer.
- **DETAIL B:** Install weatherstrips on top of drawer edges **WITH WIPER BLADE POINTING TOWARD DRIVER.**  
**IMPORTANT: Facing the weatherstrip the wrong way will funnel water into drawer: DUH!**

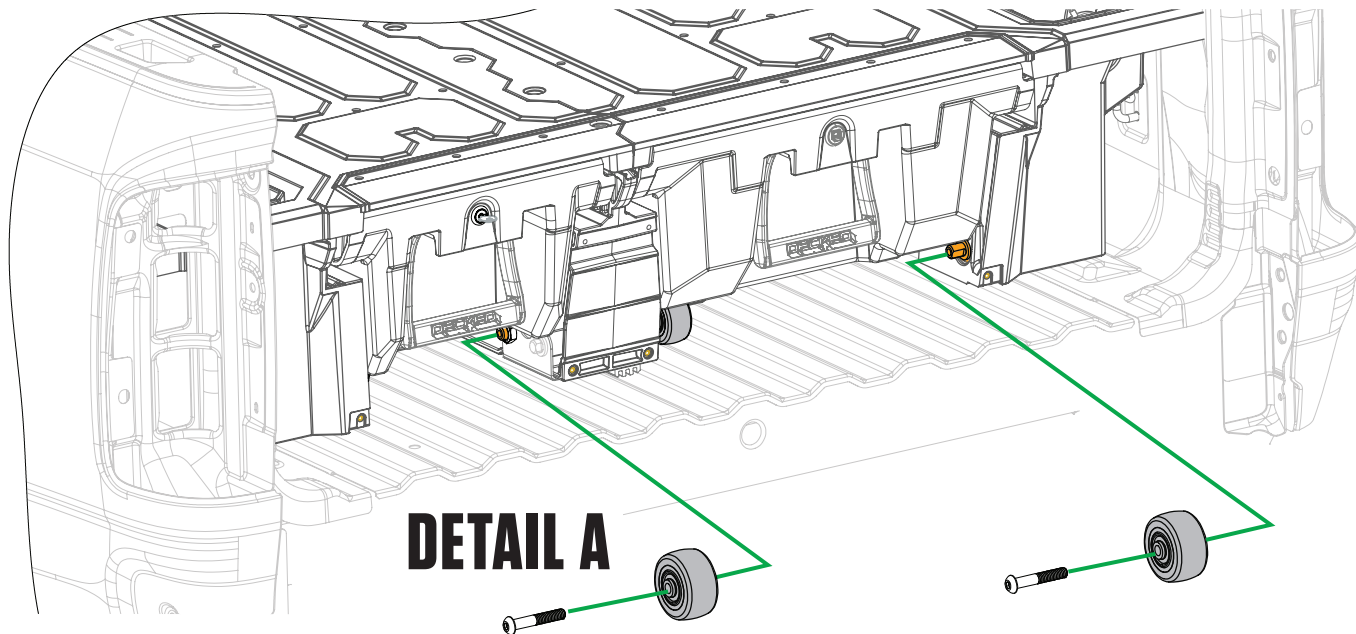

**RECOMMENDED TORQUE:**  
Wheel bolts - 90 in-lb.

**HELPFUL TIP:** To make this step easier, jam a 2" piece of material under drawer, or get your pal to pinch the drawer up to the deck to give you better leverage.

**HELPFUL TIP:** Cut weatherstrips if they overhang.

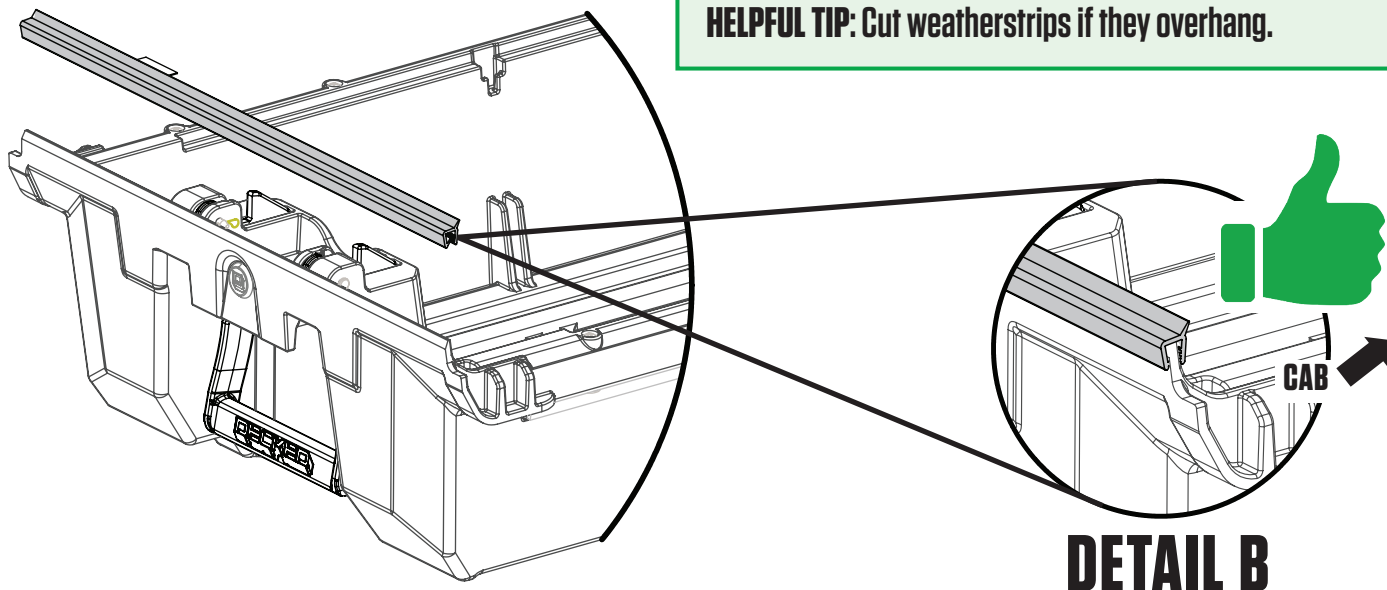

# FINAL STEPS: TORSION BRACE + BOTTLE OPENER

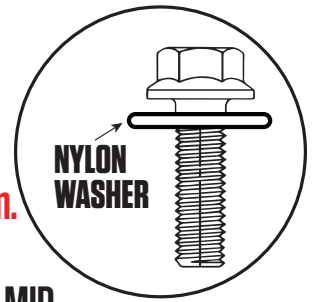

- Slide torsion brace under center vert and tailgate ammo cans.  
**NOTE: If you jumped the gun and tightened the J-hooks when installing, loosen them.**
- Loosely install:
  - Two 1/2" length bolts through upper holes in bottle opener into center vert; **BAG FINAL MID.**
  - Two bolts with nylon washers through the end holes in torsion brace into ammo cans; **BAG S1.**
  - Two bolts with nylon washers through the bottom bottle opener holes and torsion brace into center vert; **BAG S1.**
- Align bottle opener to edges of center vert and tighten four bottle opener bolts.
- Tighten end bolts into tailgate ammo cans.
- **Finally...Tighten the J-hooks! DO NOT OVER TIGHTEN, just make snug. Make sure the gap between the sidewall of the bed and the deck is equal on both sides.**
- Install bolt thread protectors on J-hook ends if provided.

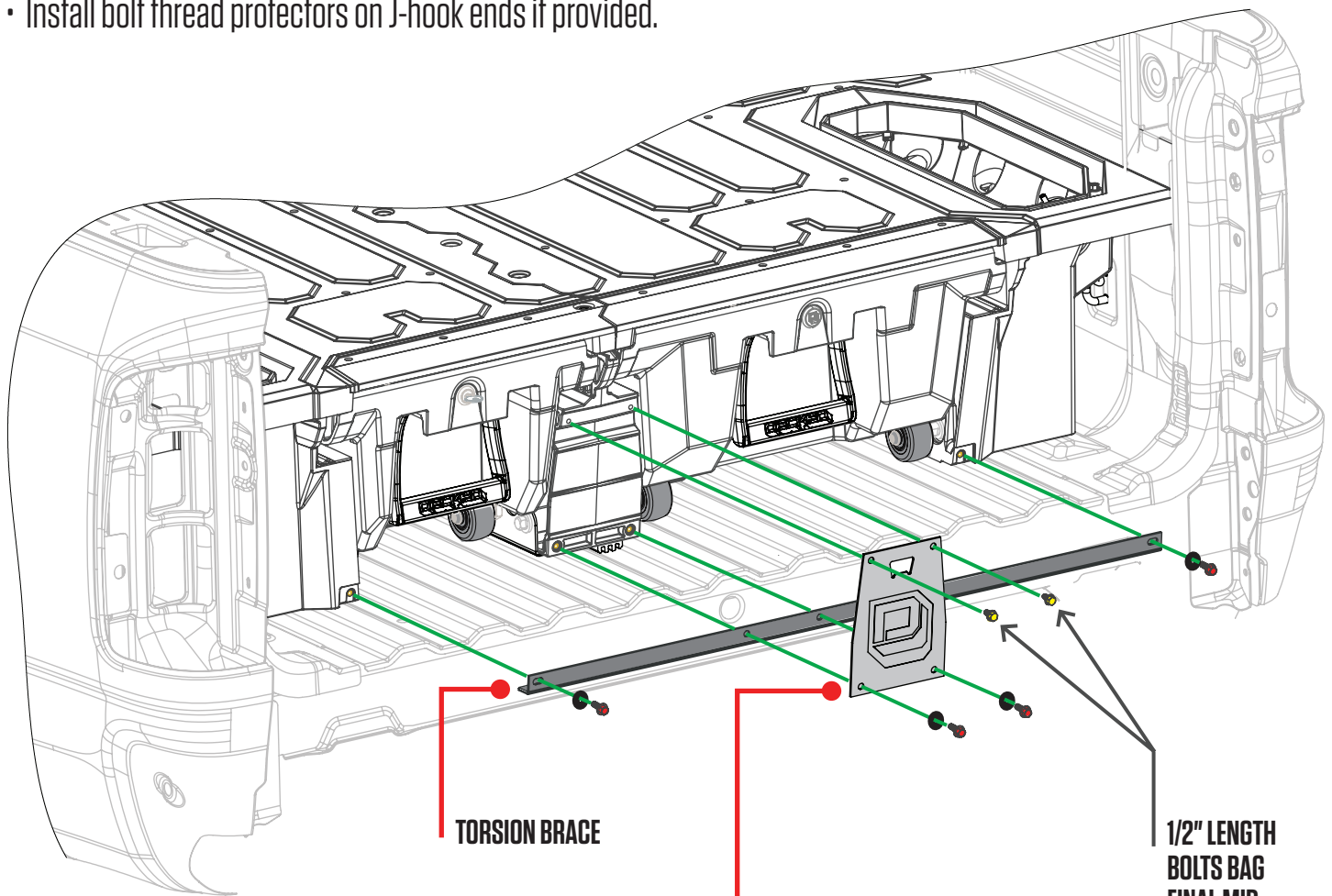

**HELPFUL TIP:** Bottle opener goes outside of torsion brace.

BOTTLE OPENER

**RECOMMENDED TORQUE:**  
Bolts in labeled bag S1 - 27 in-lb.  
J-hooks - 9 in-lb.



# BAM BAM: THE RULER

**STOP:** Look inside the **BAG FINAL MID:** If you have 6 ruler screws with 1/8" Allen heads, there is no need to drill - just install the ruler with 6 Allen head screws. If your ruler screws have Phillips heads, follow the directions below.

- Center ruler in embossed area and screw three 1/2" length Phillips screws through the tailgate side holes directly into deck panels; **BAG FINAL MID.**

**NOTE:** These are small gauge screws. Tighten to a light snuggle **ONLY.**

- For the three cabside ruler mounting holes, drill each with a 9/64" bit and a drill stop set to 1/2". There is a lateral steel tube that runs on the underside of the deck at this location. (SEE UNDERSIDE VIEW OF DECK).

**IMPORTANT:** Only drill through **TOP** of steel tube; do not drill through bottom of tube, 'lest you want to pull a Niagara Falls' and funnel water into your drawers.

- Screw three 3/4" length Phillips screws into the cabside ruler holes you just drilled; **BAG FINAL MID.**

STEEL TUBE RUNS Laterally UNDER THESE 3 RULER HOLES. THEY TAKE THE 3/4" SCREWS.

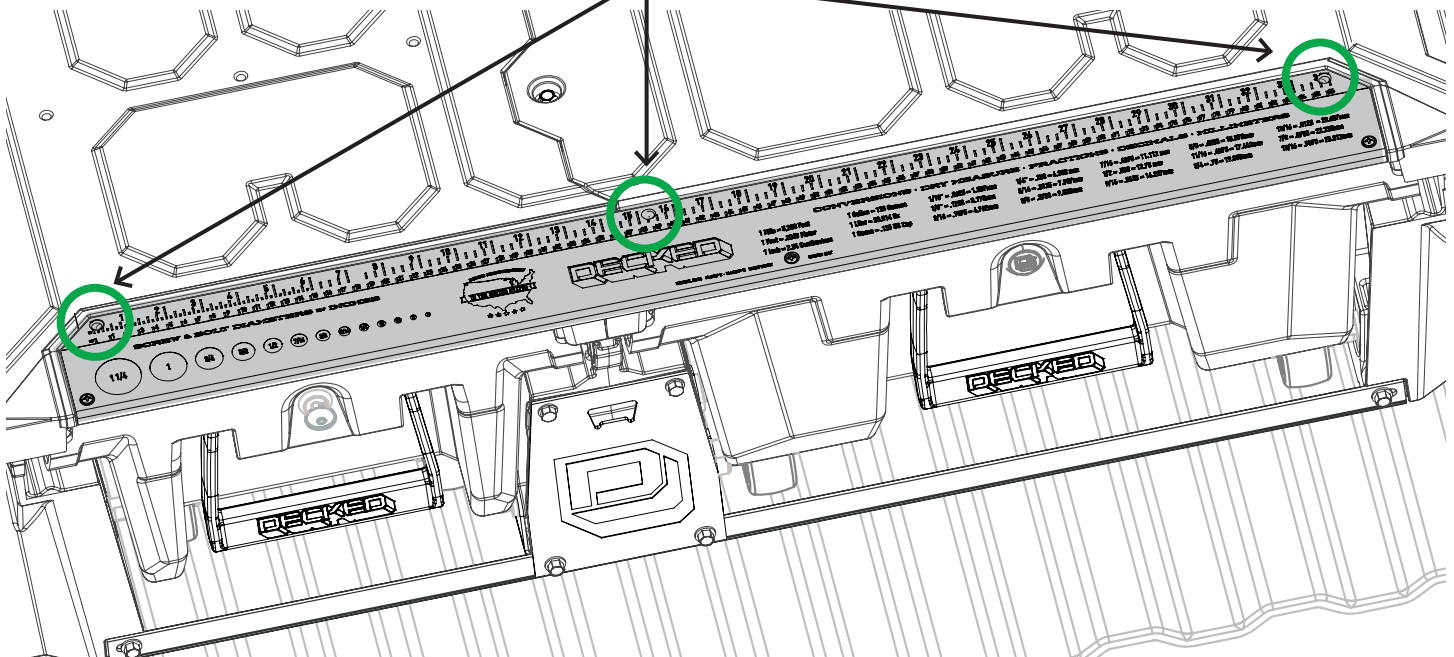

## UNDERSIDE VIEW OF DECK



**DO:** Drill through the top of steel tube ONLY.

**DO NOT:** Drill through both sides of steel tube = **YOU'RE FIRED!**



# FINAL STEPS: AMMO CAN LIDS

- **DETAIL A:** Ammo can lids are driver (marked L) and passenger (marked R) side specific.
- **DETAIL B:** Holding lid in orientation shown, insert tab on tailgate end of ammo can lid and push the cabside end of lid down to secure. Don't be afraid to give'r the Fonzi to close, it's rugged.
- Insert lock hole plugs, unless you ordered drawer locks! Install drawer locks now (instructions with locks);  
**BAG FINAL MID.**

**IMPORTANT:** Grab your favorite beverage, crack 'er open in the bottle opener and make a toast to your truck. You did it. Immediately post a photo of your significant other, child or canine (in no order of significance - please someone show us your pet alligator) appreciating your accomplishment. Add hashtag **#DECKEDUSA** | **@DECKEDUSA**.

## DETAIL A

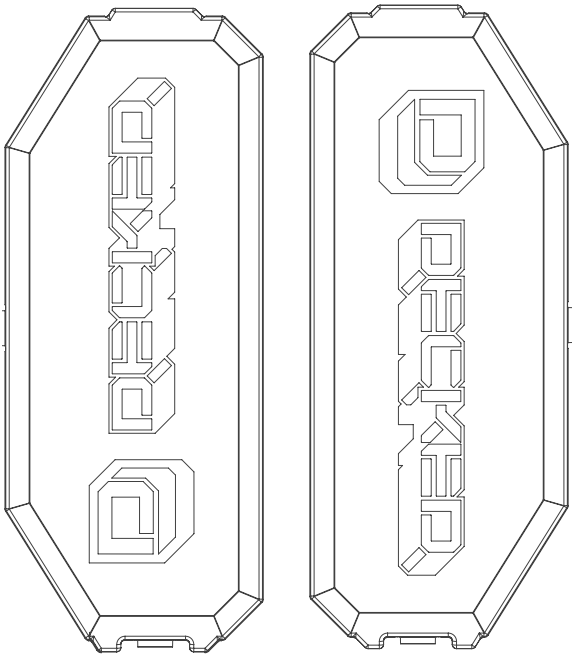

**DRIVER SIDE  
AMMO CAN LID**

**PASSENGER SIDE  
AMMO CAN LID**

## DETAIL B

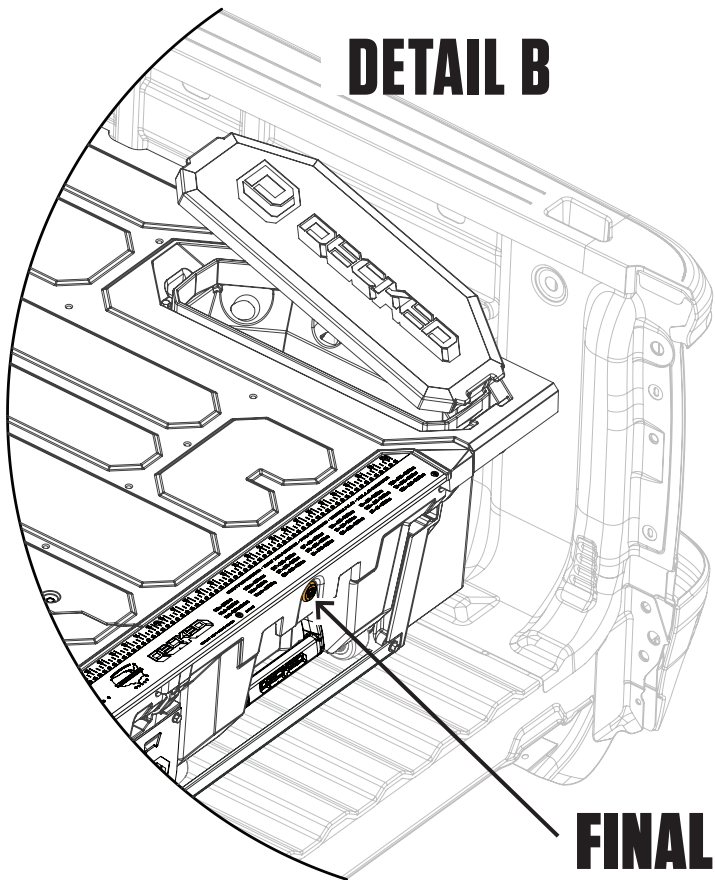

**FINAL MID**

**#DECKEDUSA | @DECKEDUSA**

# DECKED 3-YEAR LIMITED WARRANTY

(a.k.a. LEGAL MUMBO JUMBO)

DECKED LLC warrants to the original purchaser of this product that the product will be free from manufacturing defects in workmanship and materials for a period of three (3) years from the date of the original purchase. If within three (3) years from the original date of purchase this product fails due to defect in materials or workmanship, DECKED LLC will replace any defective part at its option.

The original purchaser must contact the DECKED LLC customer service team and provide a description of the defective part, including digital pictures if requested, with the original purchase documentation as validation of warranty coverage or have previously activated their warranty online.

This warranty DOES NOT cover or apply to:

- Damage to the product due to misuse, mishandling and abuse.
- Products not used in accordance with the manufacturer's instructions or recommendations.
- Product not assembled or installed according to manufacturer's instructions.
- Normal wear and tear.
- Undeclared damage to the system during shipping, acts of God. In addition, consequential damage and incidental damages (including lost time) such as damage to persons or property are not covered under this warranty.

REGISTER YOUR PRODUCT FOR ANY FUTURE WARRANTY NEEDS. [\*\*DECKED.COM/REGISTER\*\*](https://www.decked.com/register)

**#DECKEDUSA | @DECKEDUSA**