

BRACKET KIT INSTALLATION

SKU# RB-0301-BK



COMPONENTS		HARDWARE
<p>DRIVER SIDE</p> <p>Qty: 1 Front Bracket</p> <p>Qty: 1 Center Bracket</p> <p>Qty: 1 Rear Bracket</p>	<p>PASSENGER SIDE</p> <p>Qty: 1 Front Bracket</p> <p>Qty: 1 Center Bracket</p> <p>Qty: 1 Rear Bracket</p>	<p>Qty: 32 M8 Flat Washers</p> <p>Qty: 32 M8 Lock Washers</p> <p>Qty: 32 M8 Hex Head Nuts</p> <p>Qty: 18 Plastic Washers</p>
TOOLS REQUIRED		INSTALLATION NOTES
<p>RATCHET</p> <p>TORQUE WRENCH</p> <p>13MM SOCKET</p>	<p>NOTE: Center Bracket is ONLY used on Crew Cab Models</p> <p>TORQUE NOTE: Bolts and nuts should be torqued to 15-20 ft lbs.</p> <p>NOTE: Hardware for Board Installation is included.</p> <p>NOTE: Some spare hardware is included.</p>	

Remove all contents from the package and check brackets for any damage. Also, verify that all components and hardware listed above are included before you begin installation. If anything is missing or damaged please contact us at customerservice@cyc-engineering.com

Read through entire installation manual and installation drawings to ensure that you understand all of the components and hardware before proceeding with installation.

NOTE: When installing the brackets, all hardware must be left loose until all of the items are attached.

Locate factory hole locations in three (3) places per side on the body mount.

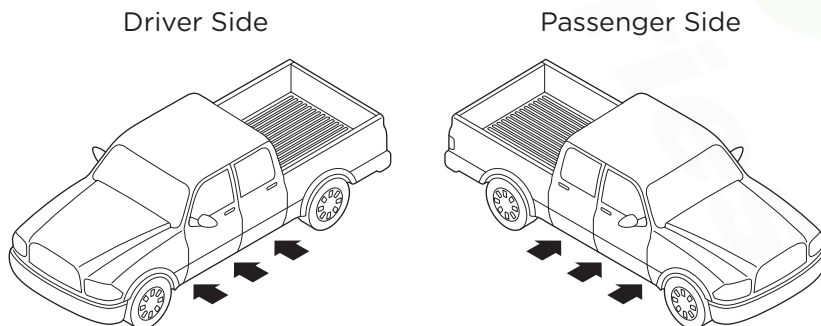

BRACKET ORIENTATION

DRIVER SIDE

NOTE: Center Bracket is ONLY used on Crew Cab Models

Raptor
Series

1. Begin installation on driver side. Position the Front Bracket, Center Bracket and Rear Bracket as shown in diagram.

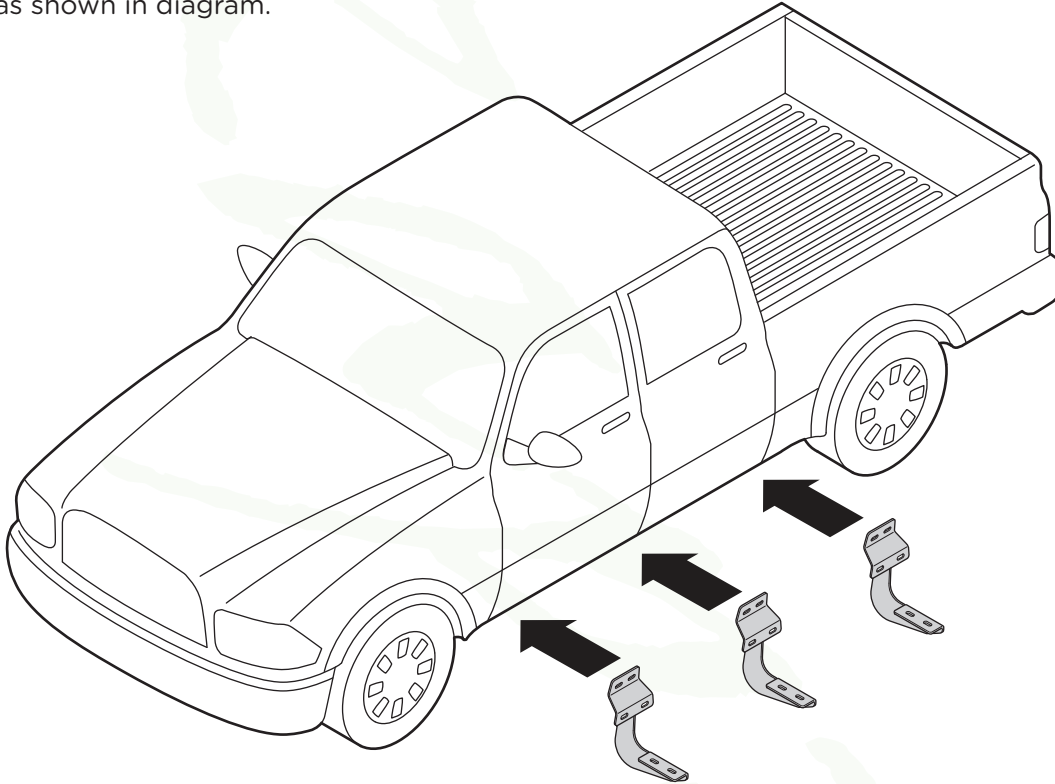

2. Driver Side Front Bracket cradle (2a), Driver Side Center cradle (2b) and Rear Bracket cradle (2c) will face toward the front of the truck.

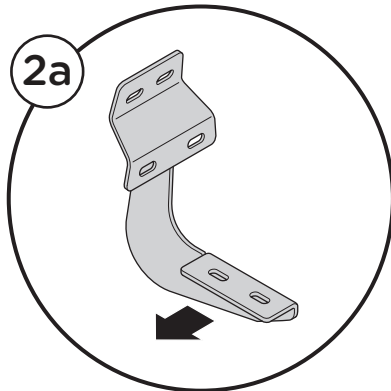

Driver Side
Front Bracket

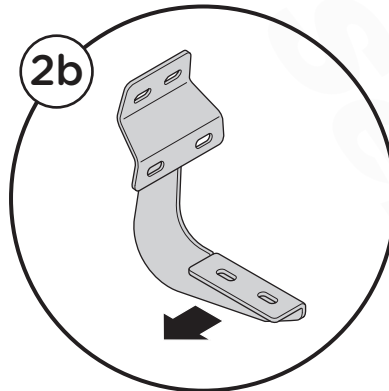

Driver Side
Center Bracket

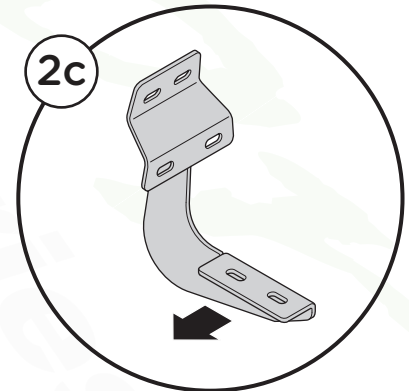

Driver Side
Rear Bracket

BRACKET INSTALLATION

DRIVER SIDE

Raptor
Series

- 3.** Locate the three existing Mounting Studs located on the interior wall of the Rocker Panel. Place Plastic Washers onto each Mounting Stud to prevent corrosion caused by aluminum to steel contact. Repeat for all bracket locations.

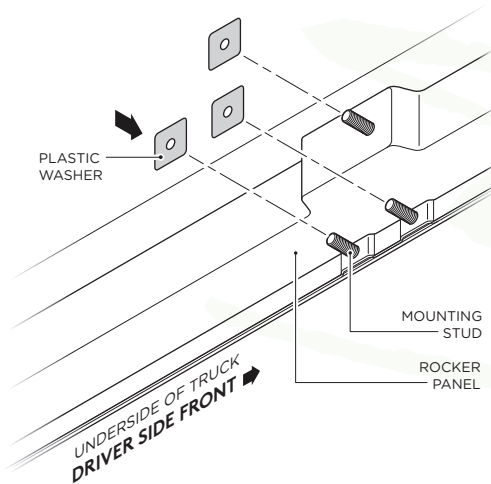

- 4.** Fasten the top portion of the Driver Side Front Bracket by using (2) M8 x 30MM Hex Head Nuts, (2) M8 Flat Washers and (2) M8 Lock Washers.

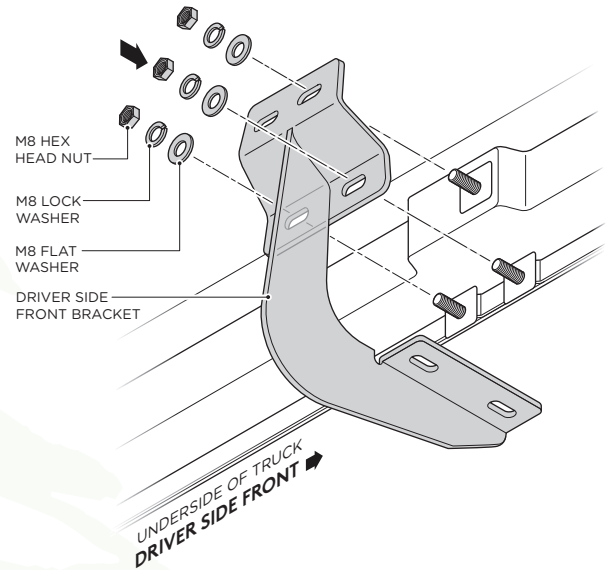

- 5.** Fasten the top portion of the Driver Side Center Bracket by using (2) M8 x 30MM Hex Head Nuts, (2) M8 Flat Washers and (2) M8 Lock Washers.

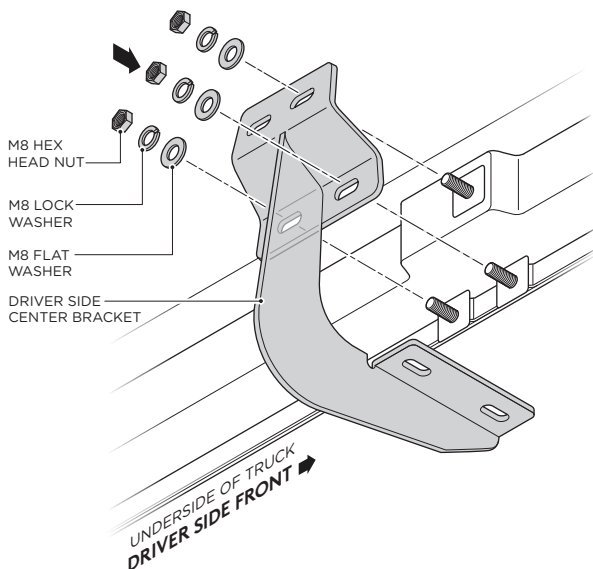

- 6.** Fasten the top portion of the Driver Side Rear Bracket by using (2) M8 x 30MM Hex Head Nuts, (2) M8 Flat Washers and (2) M8 Lock Washers.

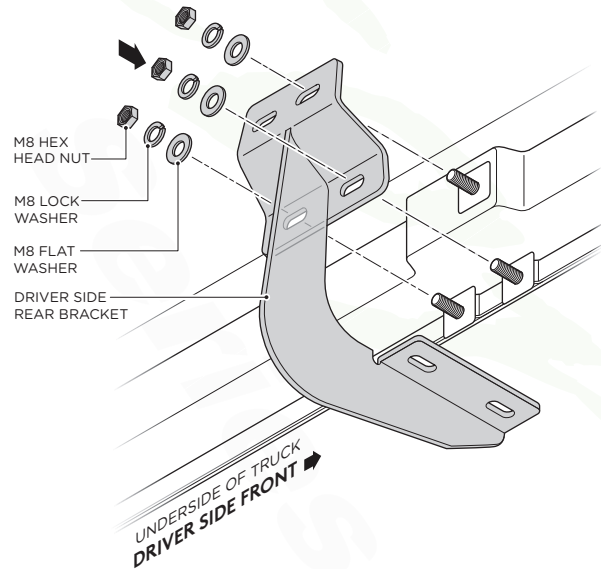

*Crew Cab Models ONLY

BRACKET ORIENTATION

PASSENGER SIDE

NOTE: Center Bracket is ONLY used on Crew Cab Models



1. Begin installation on passenger side. Position the Front Bracket, Center Bracket and Rear Bracket as shown in diagram.

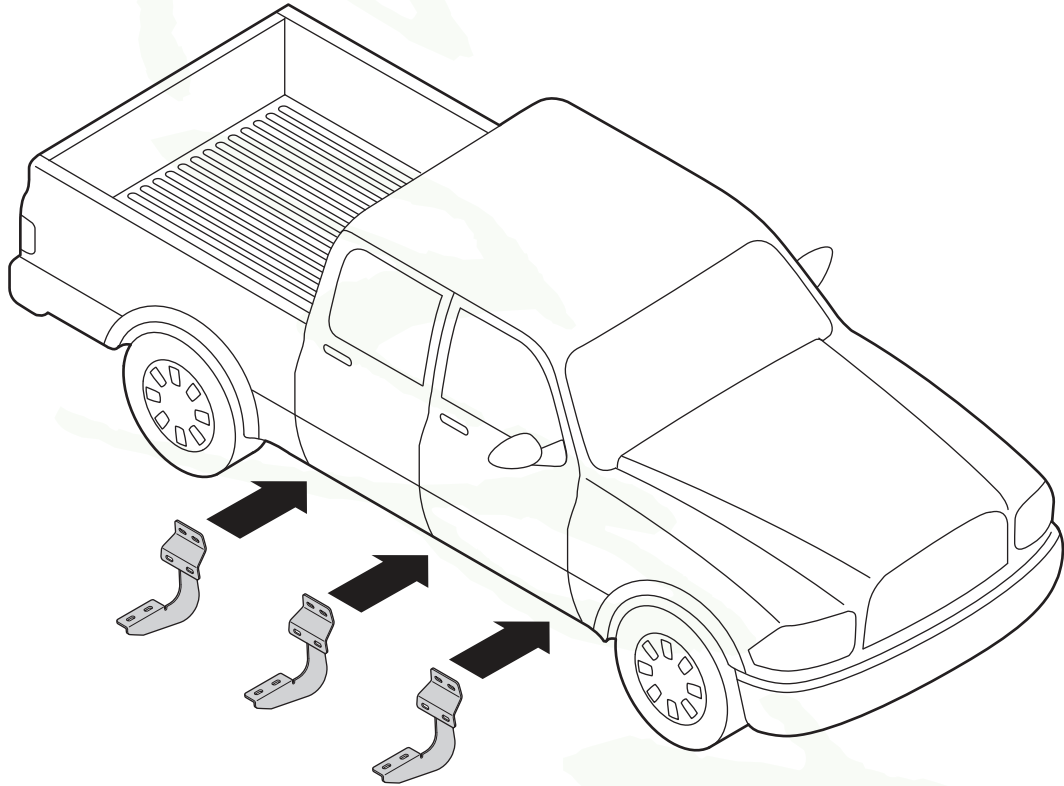

2. Passenger Side Front Bracket cradle (2a), Center Bracket cradle (2b) and Rear Bracket cradle (2c) will face toward the rear of the truck.

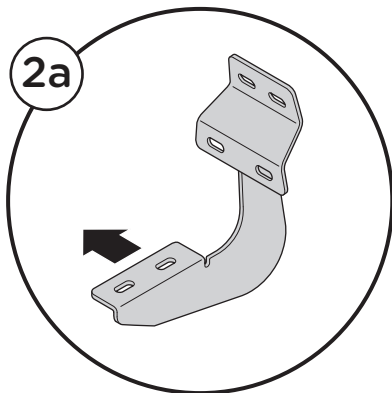

Passenger Side
Front Bracket

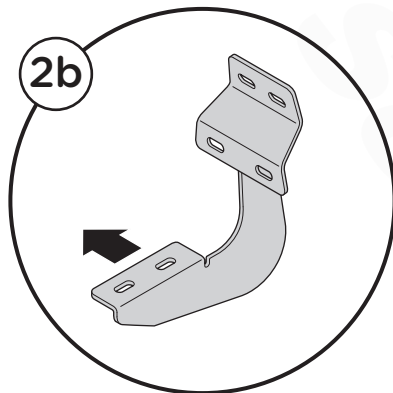

Passenger Side
Center Bracket

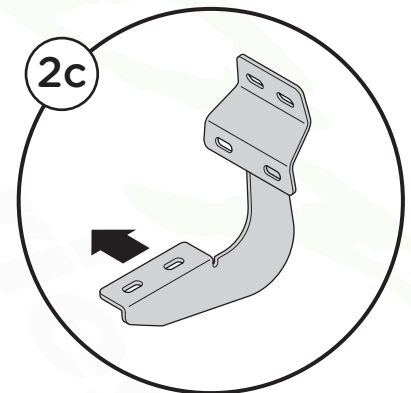

Passenger Side
Rear Bracket

BRACKET INSTALLATION

PASSENGER SIDE



- 3.** Locate the three existing Mounting Studs located on the interior wall of the Rocker Panel. Place Plastic Washers onto each Mounting Stud to prevent corrosion caused by aluminum to steel contact. Repeat for all bracket locations.

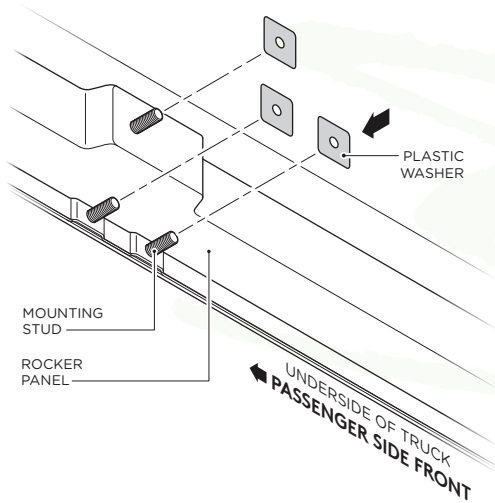

- 4.** Fasten the top portion of the Passenger Side Front Bracket by using (2) M8 x 30MM Hex Head Nuts, (2) M8 Flat Washers and (2) M8 Lock Washers.

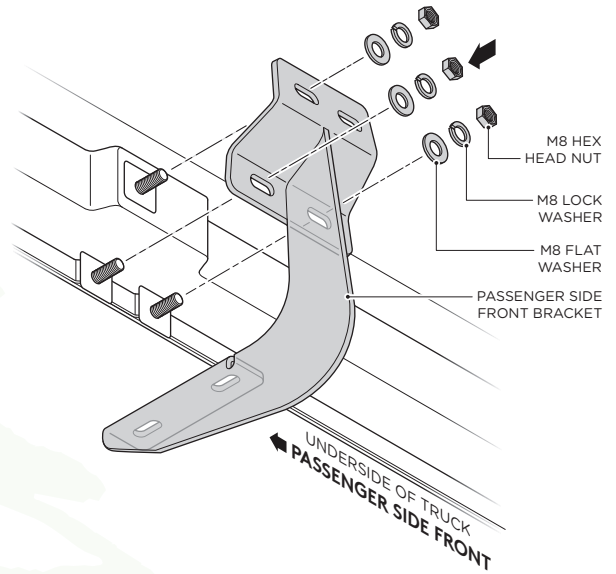

- 5.** Fasten the top portion of the Passenger Side Center Bracket by using (2) M8 x 30MM Hex Head Nuts, (2) M8 Flat Washers and (2) M8 Lock Washers.

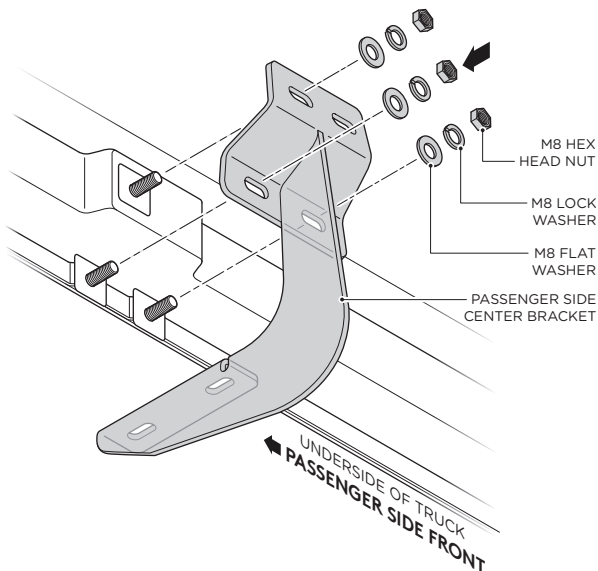

- 6.** Fasten the top portion of the Passenger Side Rear Bracket by using (2) M8 x 30MM Hex Head Nuts, (2) M8 Flat Washers and (2) M8 Lock Washers.

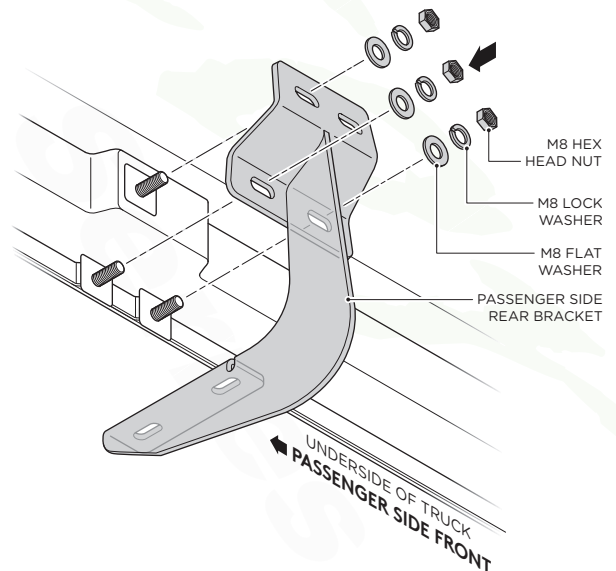

*Crew Cab Models ONLY

6.5" SAWTOOTH RUNNING BOARD

ADAPTER PLATE INSTALLATION

Raptor
Series

1. Flip Running Board over. Place each Backing Plate and each Bolt Adapter Plate together (1a) and place onto underside of the running board and through the notch (1b). Slide plates into channels of running board and position plates so they line up approximately with existing mounting bracket location (1c).

Note: It might be helpful to position the underside of running board parallel to the existing mounting plates already installed on your vehicle, so you can align the Backing Plate/Bolt Adapter more accurately.

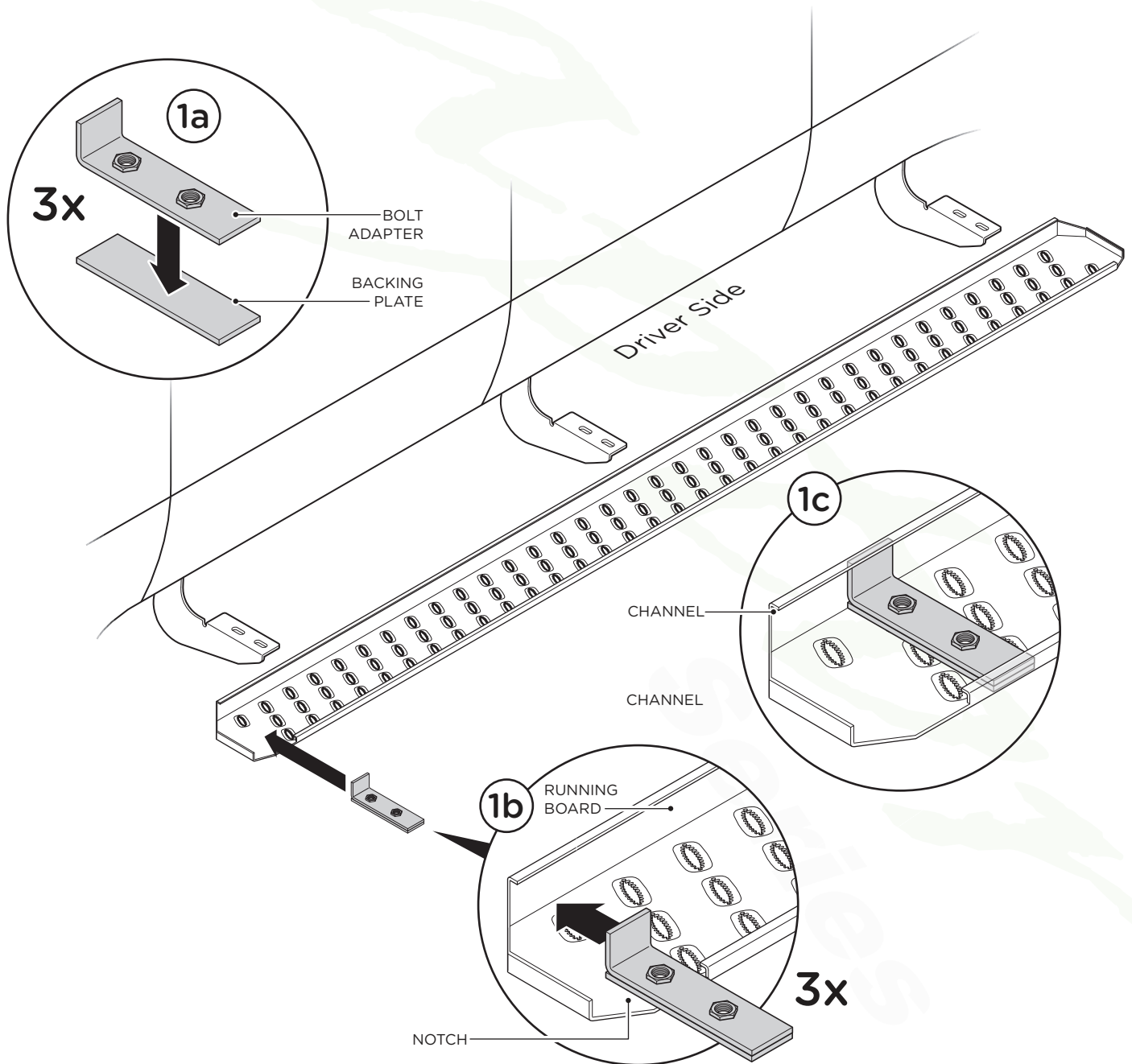

6.5" SAWTOOTH RUNNING BOARD ADAPTER PLATE INSTALLATION

Raptor
Series

2. You may need to adjust the plates slightly to align with the existing brackets (2a). Once aligned, insert provided allen drive studs into the holes on the Bolt Adapter Plate (2b), and finger tighten to hold both plates securely in place (2c), while still allowing for further adjustment to match up with vehicle mounting brackets. Repeat steps 1 and 2 for passenger side.

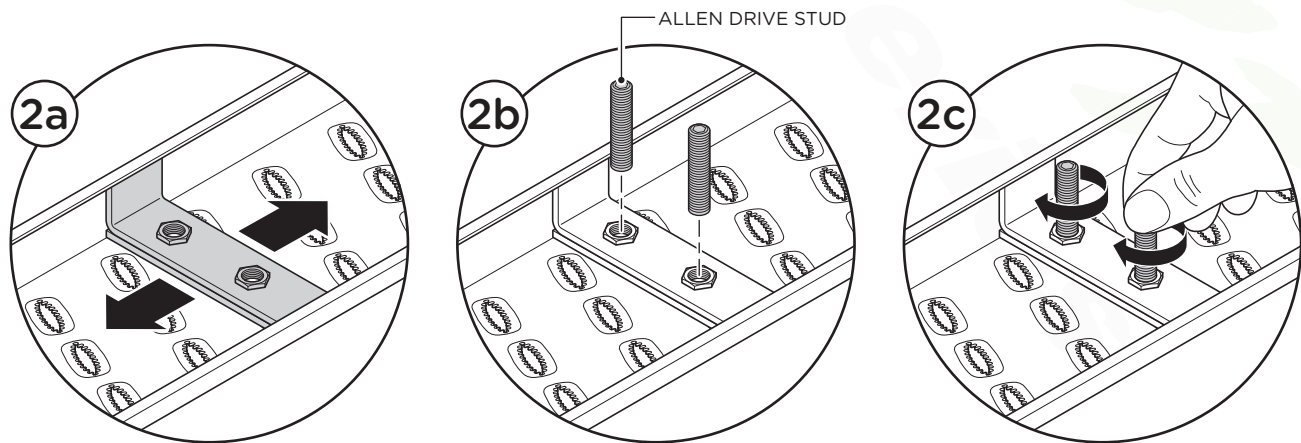
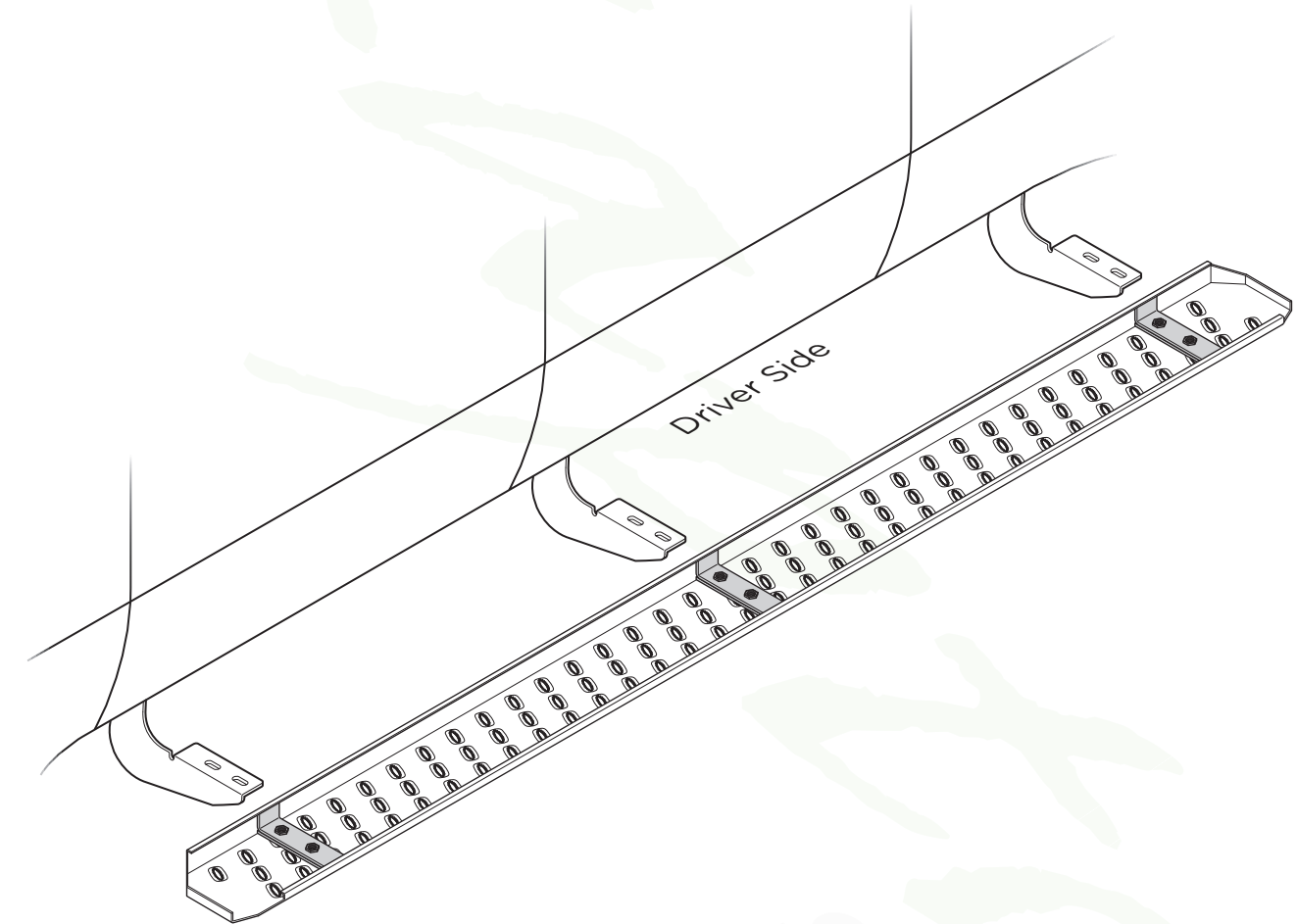

6.5" SAWTOOTH RUNNING BOARD

BOARD INSTALLATION



3. Tighten allen drive studs with allen wrench (3a). Place Running Board on brackets (3b). Each running board is marked Driver and Passenger.

4. Align each allen drive stud with each hole in the bracket. Place the spacer plate in between the bracket and the board when installing.

5. Fasten Running Board on each bracket by using two (2) M8 Flat Washers, two (2) M8 Lock Washers and two (2) M8 Hex Head Nuts per bracket.

When all hardware is in place, everything must be tightened. Tighten until the split lock washer is flat between the M8 Flat Washer and M8 Hex Head Nut.

Repeat these steps for driver & passenger side installation.

