

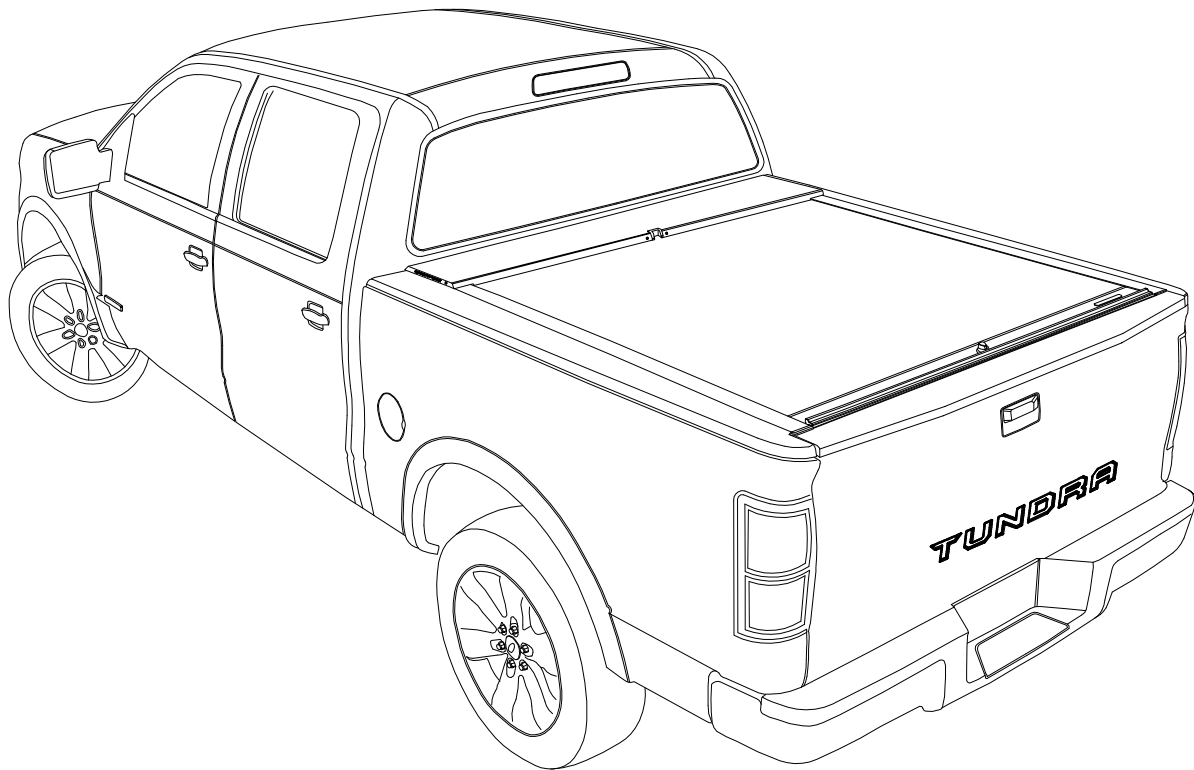

# Installation Guide

## Toyota Tundra



Product Code  
575 - 576  
575-XT - 576-XT

# Parts List

Item	Part Name	Qty.	Item	Part Name	Qty.	Item	Part Name	Qty.
A	Housing	1	G	Cargo Nut	2	M	1/4-20 x 3/8" Screw	4
B	Track	2	H	5/16" Lock Washer	4/6	N	Rubber Washer	4
C	Cargo Shield	1	I	5/16" x 3/4" Cap Screw	4/6	O	1/4" Lid Screw	2
D	Drain Tube	2	J	Shim	4/6	P	Butyl Caulk Strip	4
E	Tundra "L" Bracket	4/6	K	6m x 25mm Pan Head	4/6	Q	Allen Wrench (1/4")	1
F	#10-24 Screw	2	L	1/4" Flat Washer	4/6		303 Vinyl Protector	1

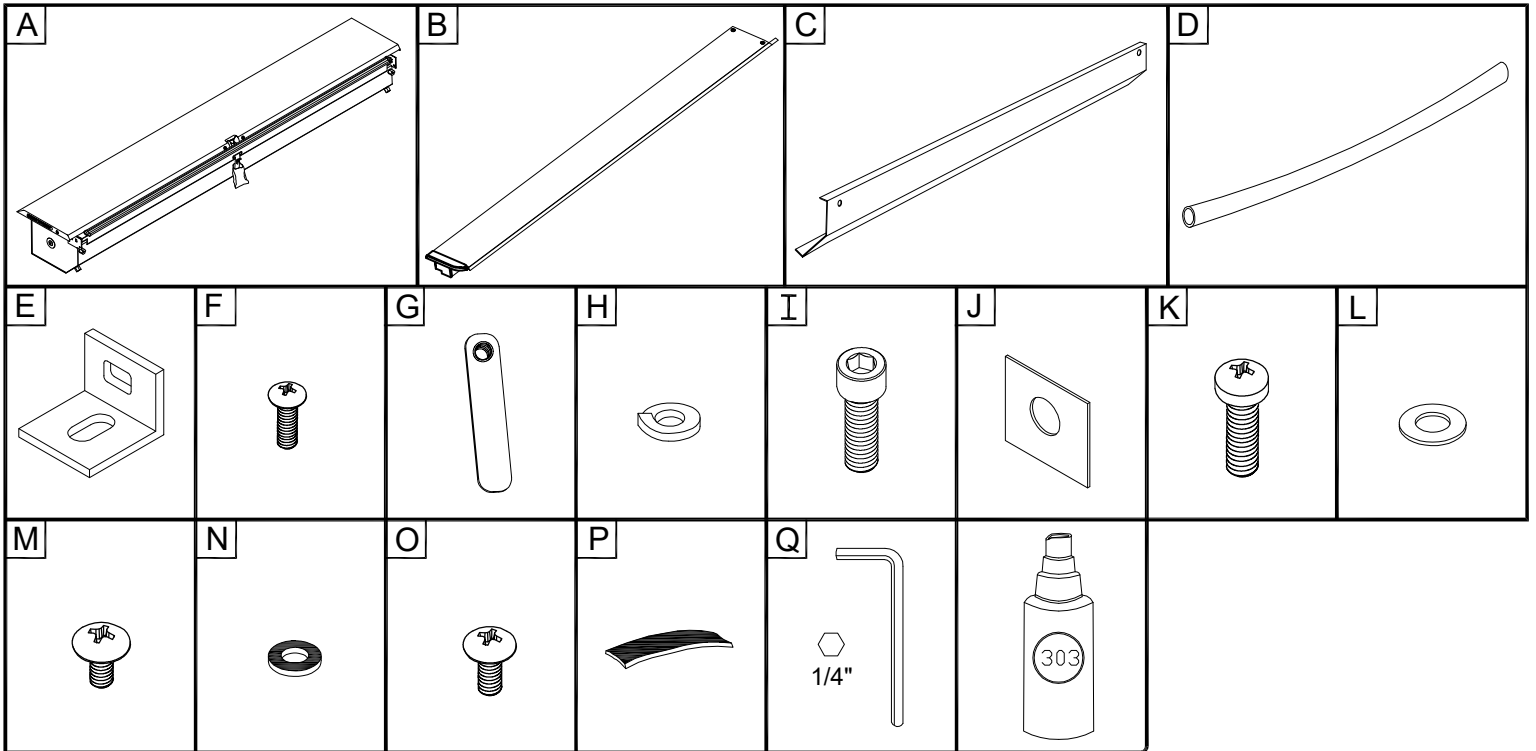

## Tools Needed

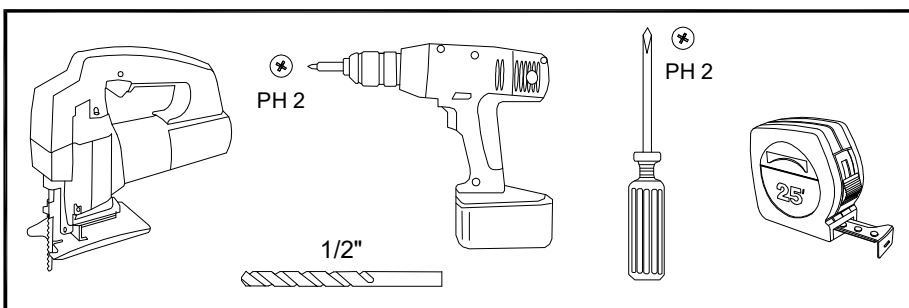

1

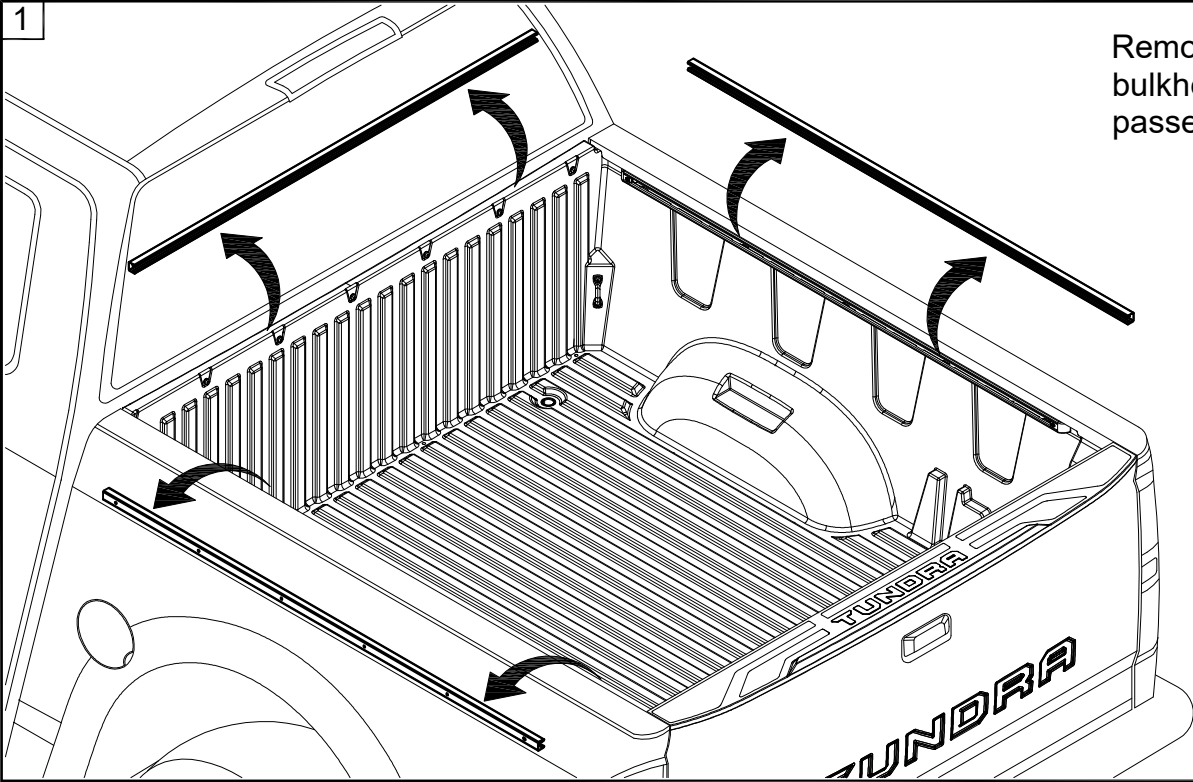

Remove rail channels at bulkhead and on driver and passenger side.

2

Press butyl strip (P) between the seam on driver and passenger side.

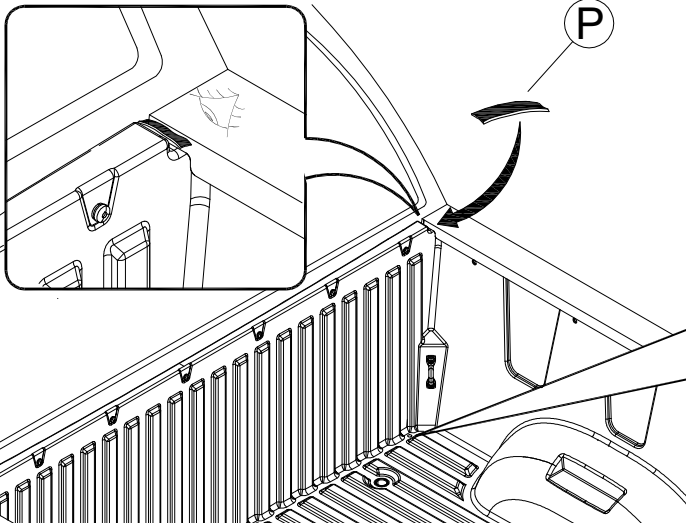

Drill 1/2" hole through existing hole in bed floor on driver and passenger side.

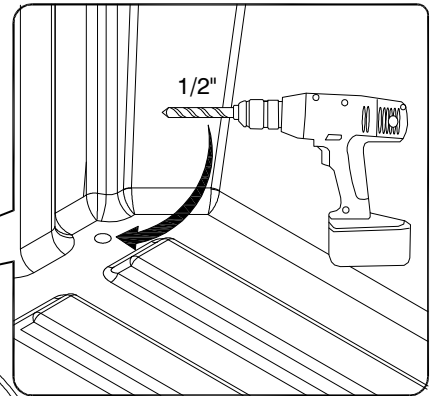

3

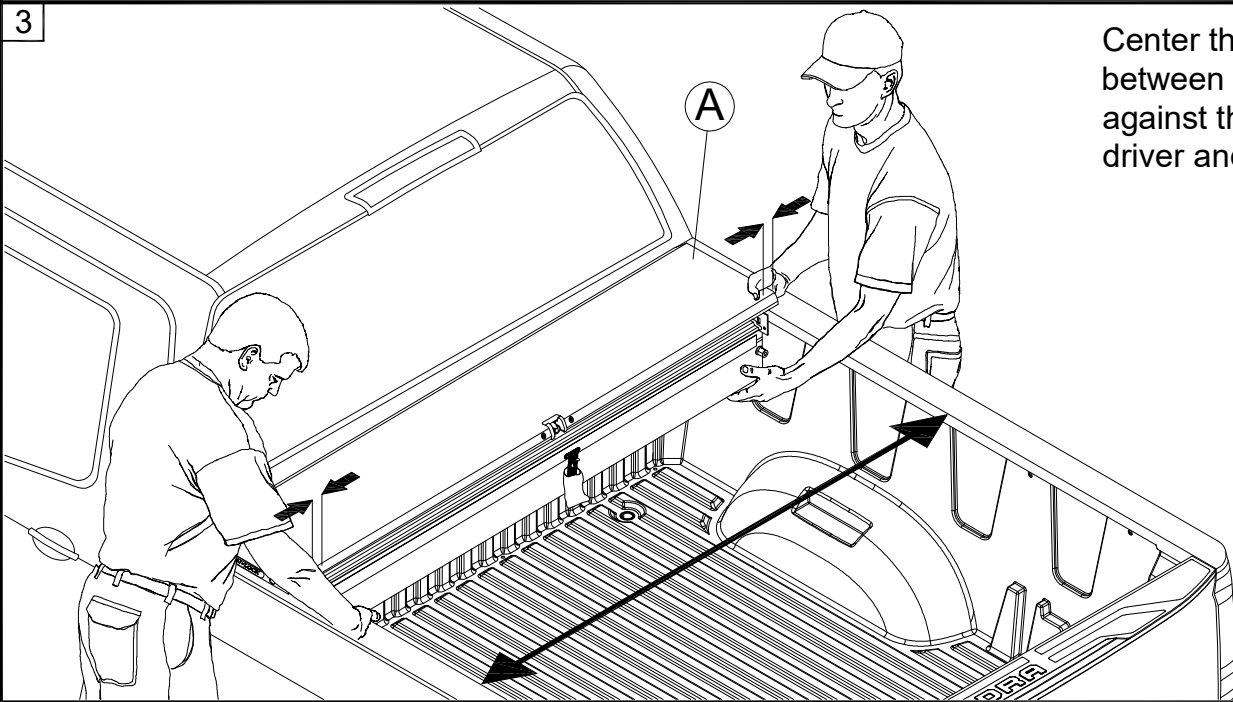

Center the Housing (A) between the bed rails up against the bulkhead on driver and passenger side.

4

Remove lid from housing by pushing toward cab (1) and up (2) on driver and passenger side.

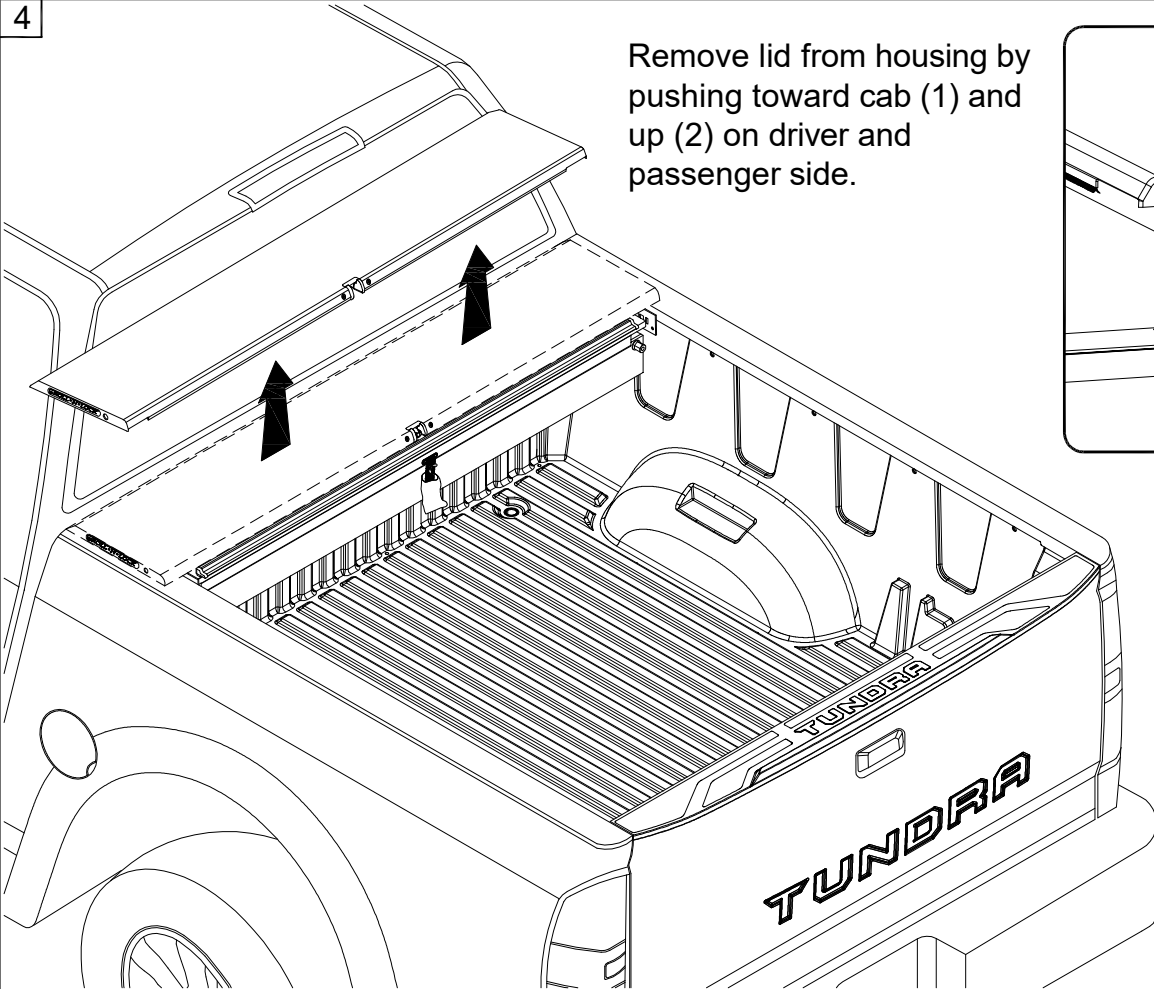
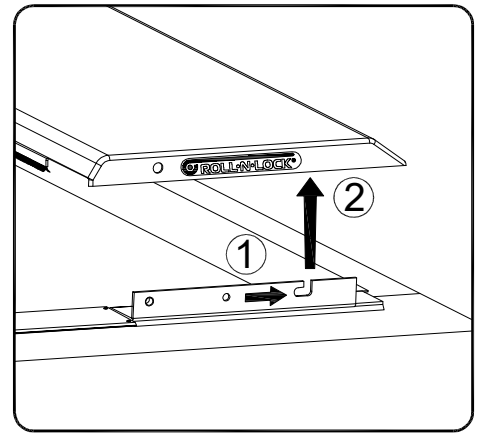

5

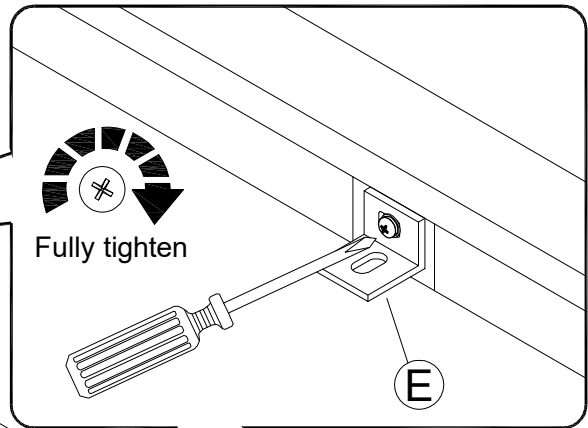

Attach "L" bracket (E) to holes (2) and (5) from rail channels using screw (K) and flat washer (L) on driver and passenger side.

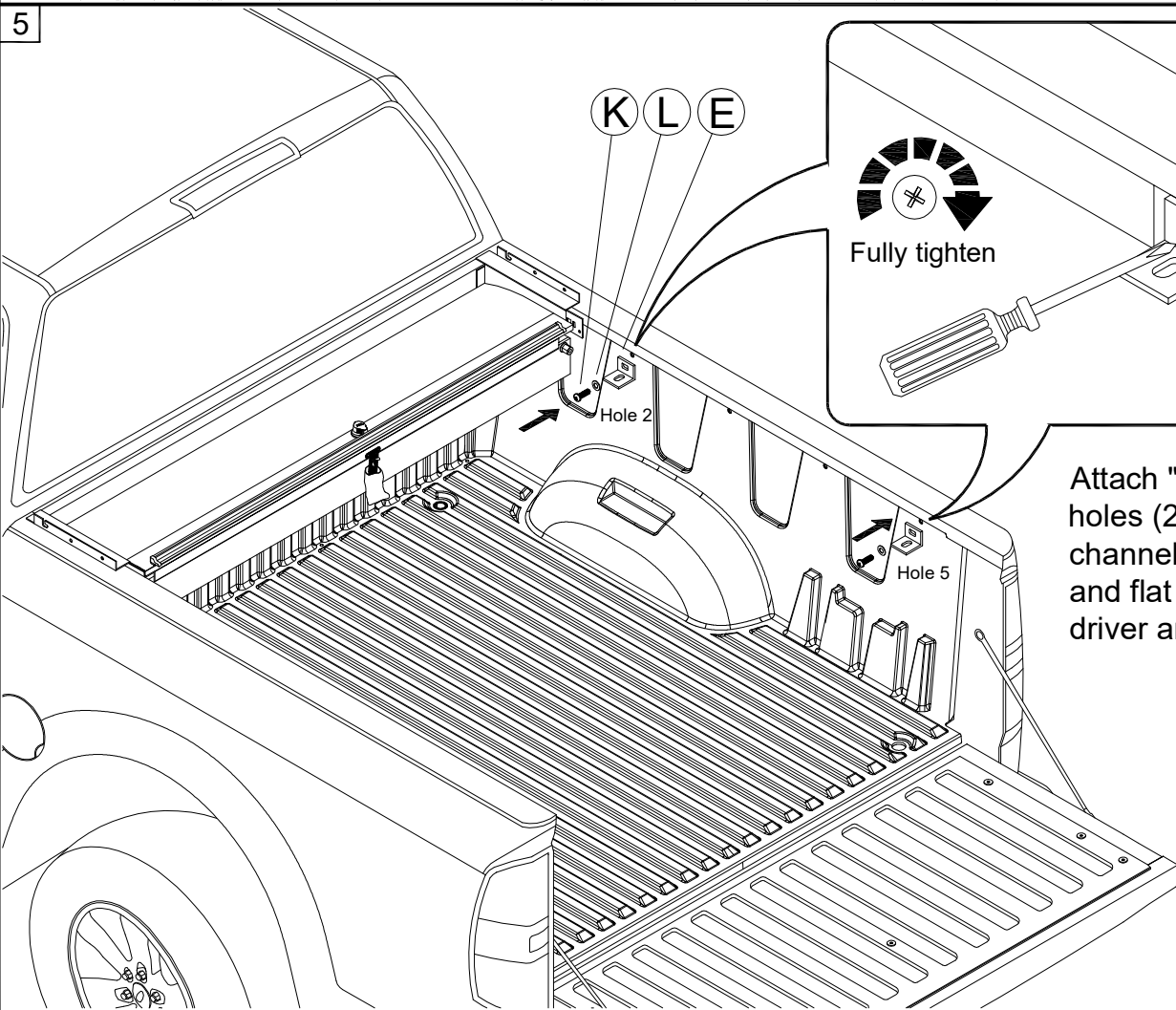

6 (1) Turn lock to 10 o'clock, key tracks (B) onto housing stems.  
(Do **not** remove plastic wing nut.)  
Make sure the edge of the key tracks butt up against housing (2 & 3) on driver and passenger side.

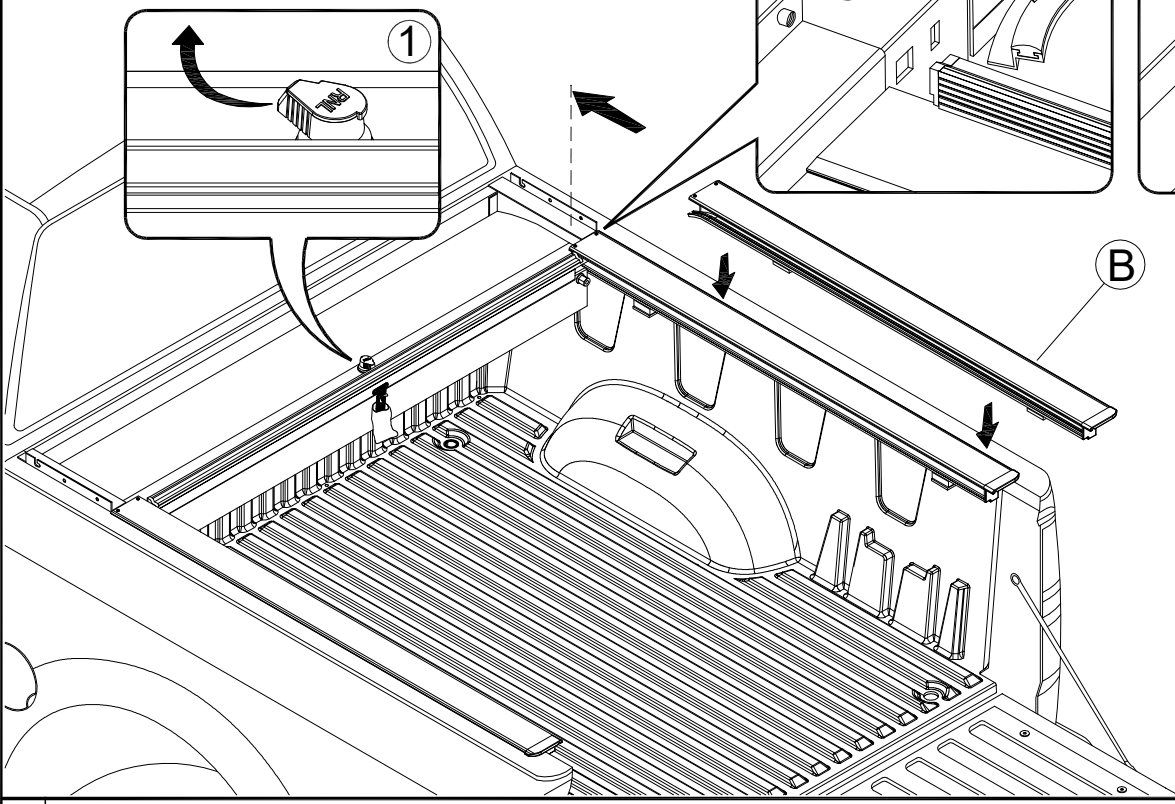

7 Secure tracks (B) to housing stem on driver and passenger side using cargo nut (G) and #10-24 screw (F).

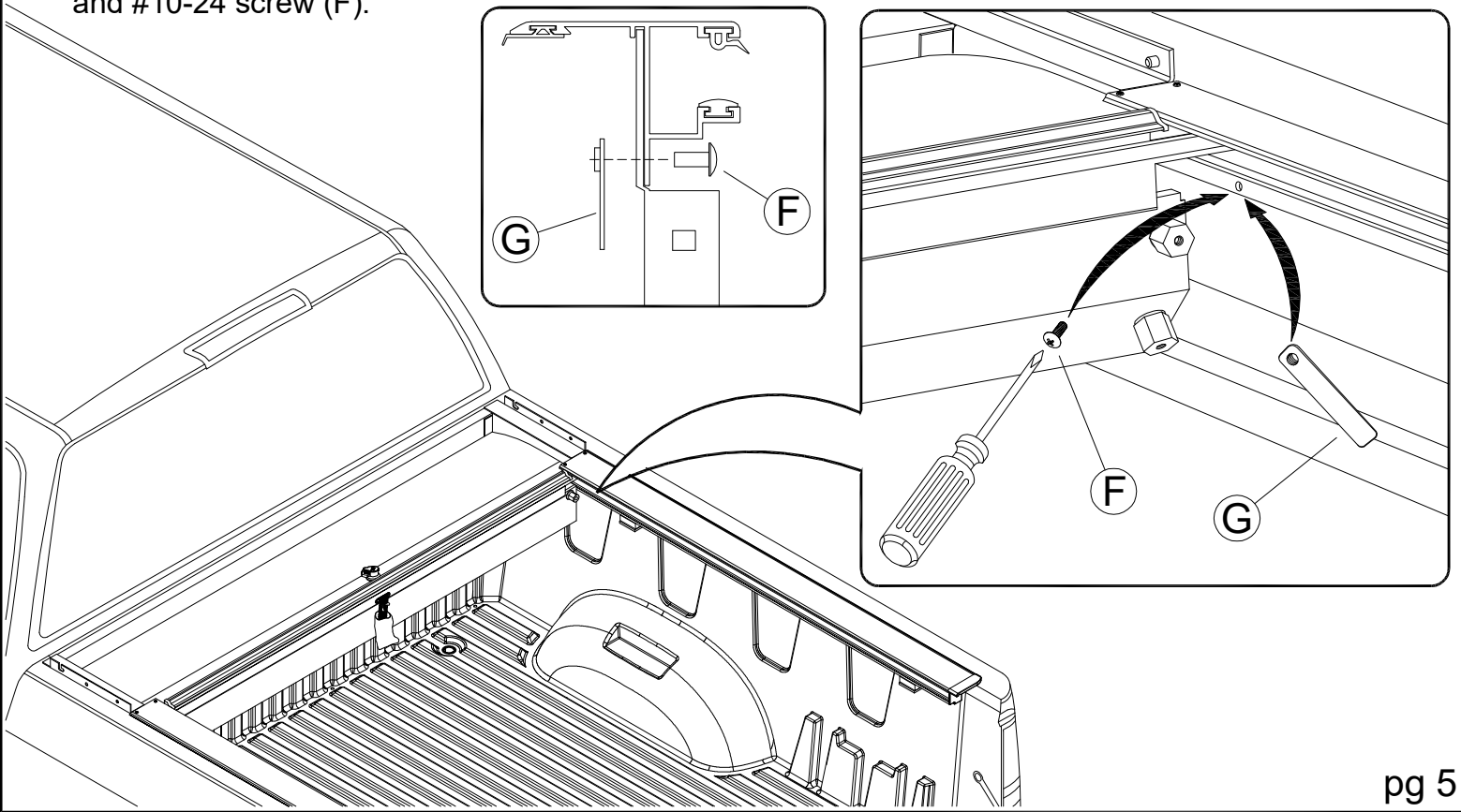

8

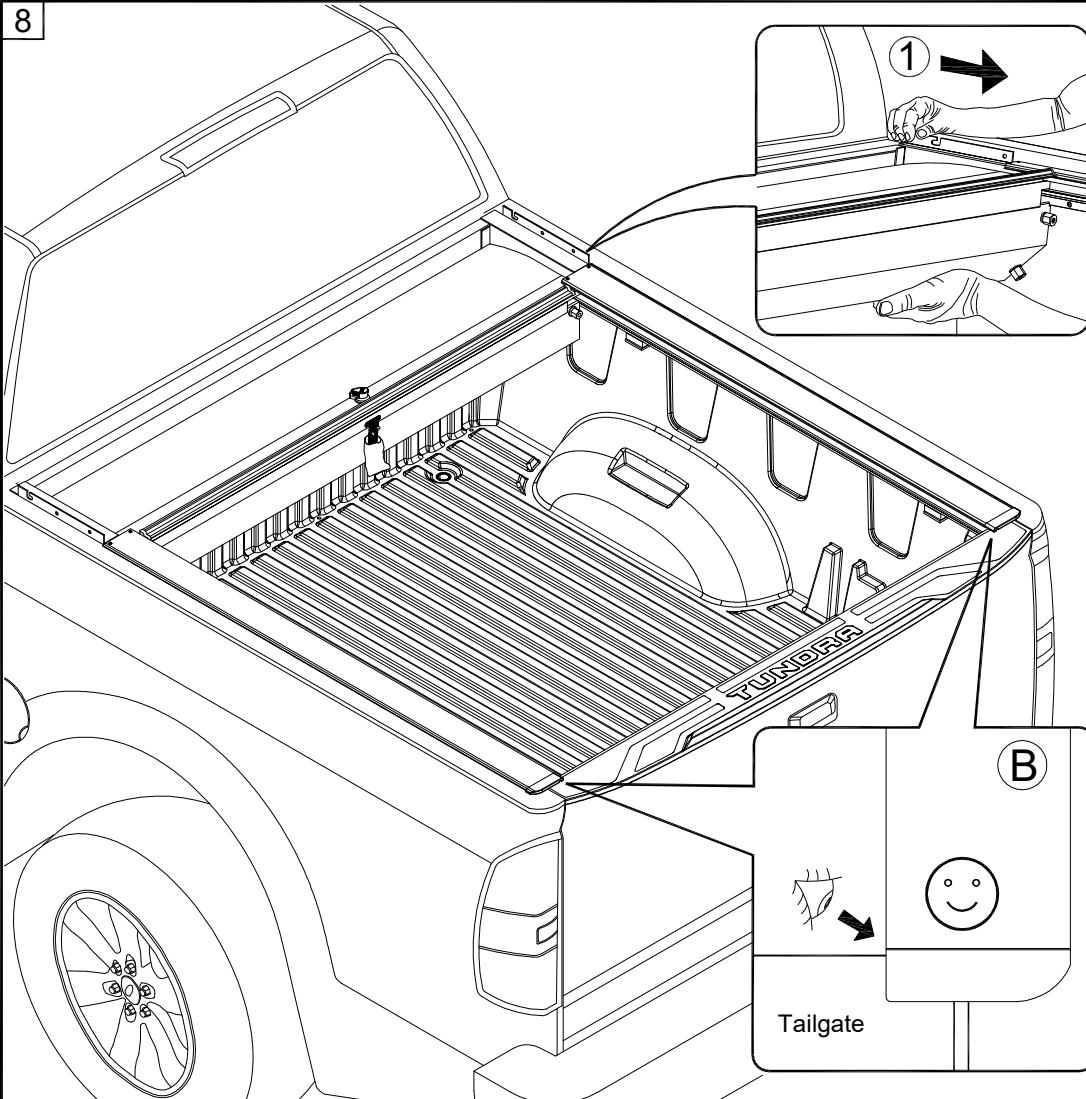

Close tailgate, shift the housing (A) back so the end of the tracks (B) are up against the tailgate on driver and passenger side.

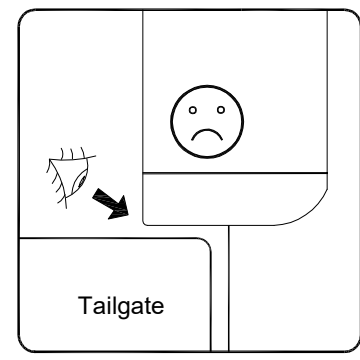
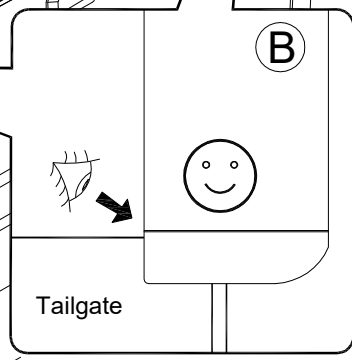

9

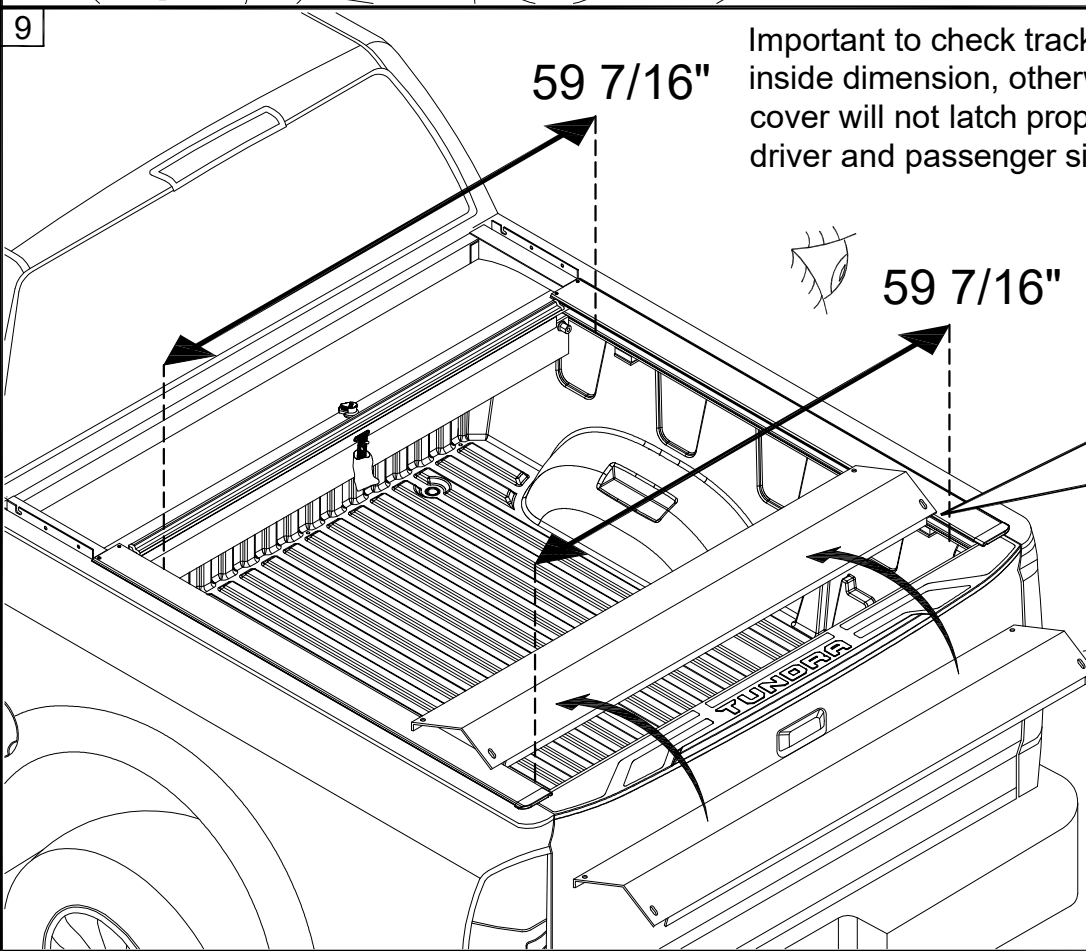

Important to check track to track inside dimension, otherwise the cover will not latch properly on driver and passenger side.

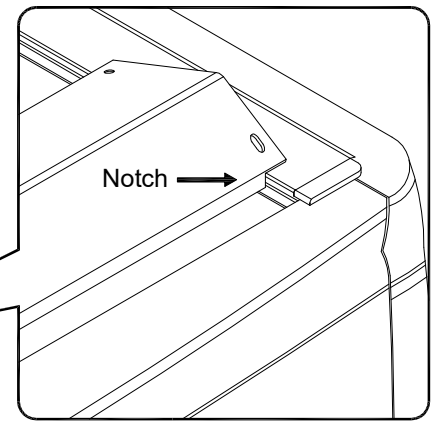

**(C)**  
 Use cargo shield (C) notches to ensure correct spacing of tracks.

Once tracks (B) are correctly spaced and adjusted to the correct height, tighten fasteners at the back (tailgate) first on driver and passenger side. Tighten fasteners at front second.

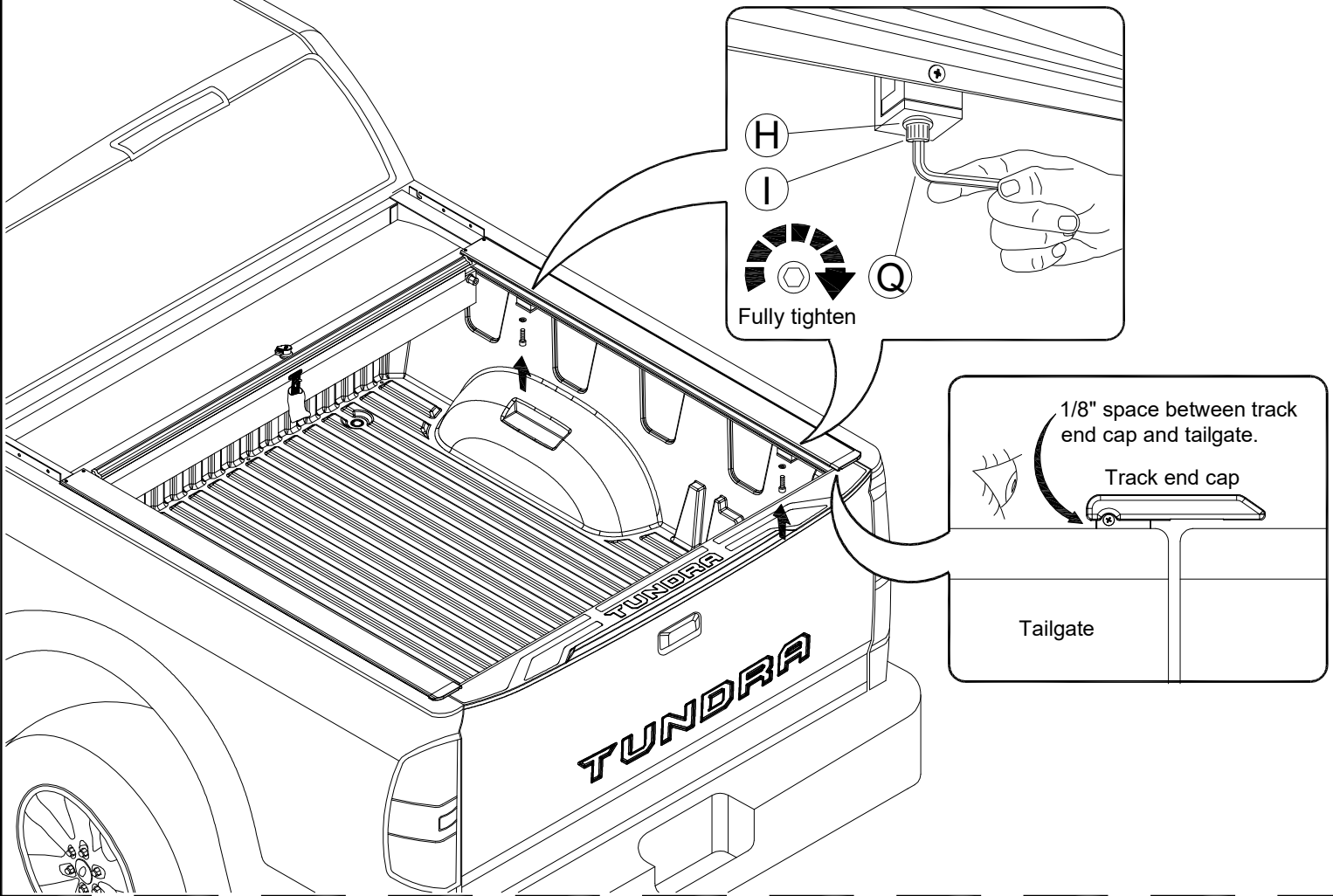

### Track Adjustment

Angle and track clamp do not line up.

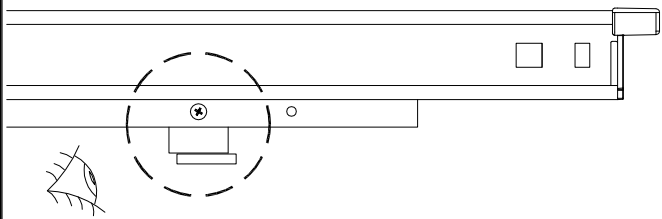

Lift track and shift angle to line up with track clamp.

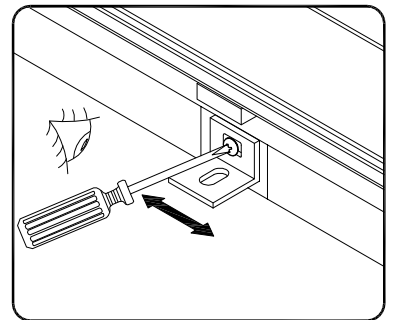

Space between track and angle.

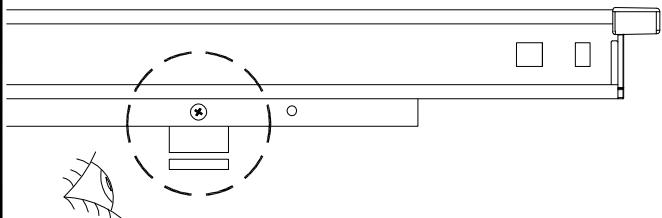

Use supplied shim between angle and track clamp to adjust height of track.

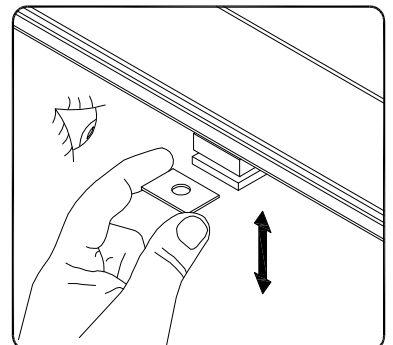

11

Turn lock to 7 o'clock, remove plastic wing nut (2) and using both hands pull cover back to tailgate.

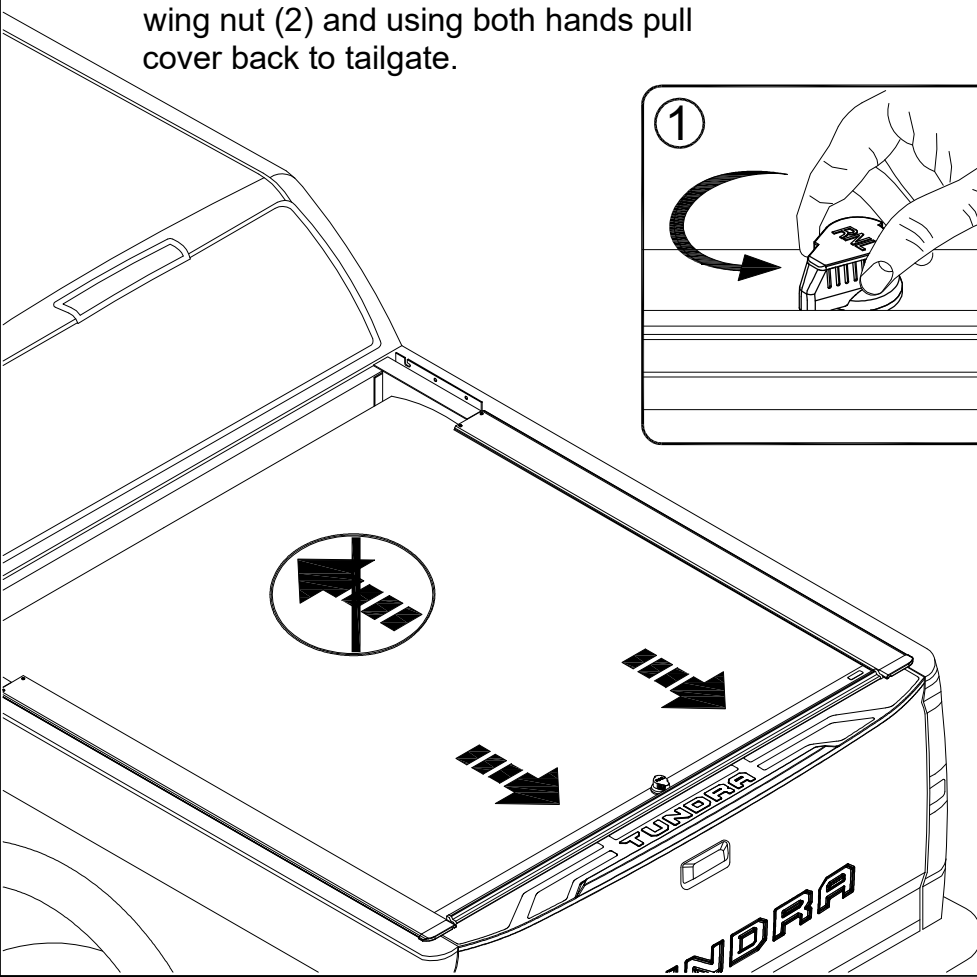
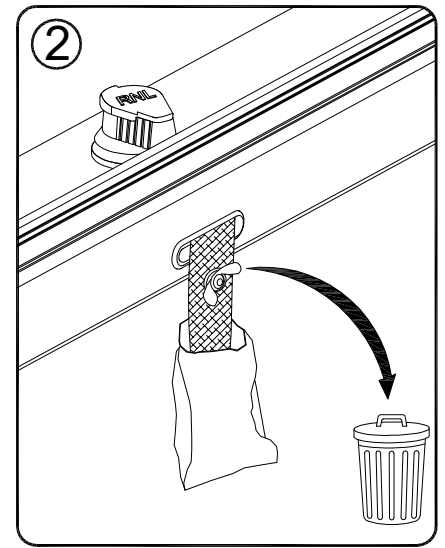
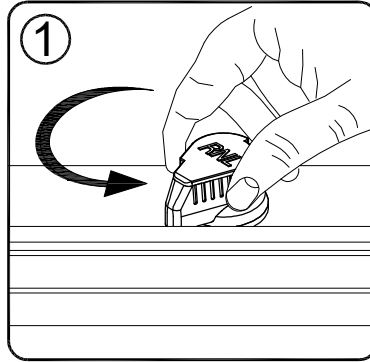

12

Replace lid by pushing down (1) and toward tailgate (2) on driver and passenger side. Then install the lid screws (O) with Phillip screw driver on driver and passenger side.

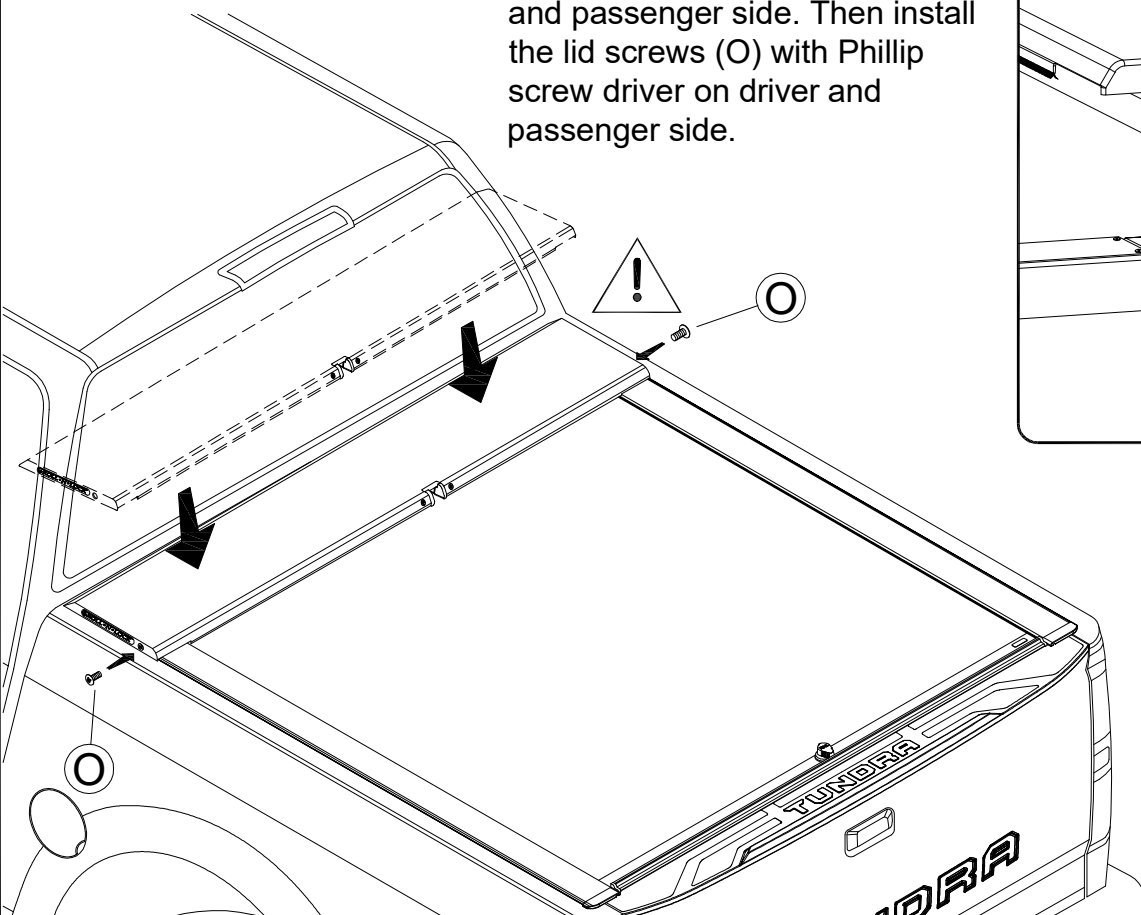
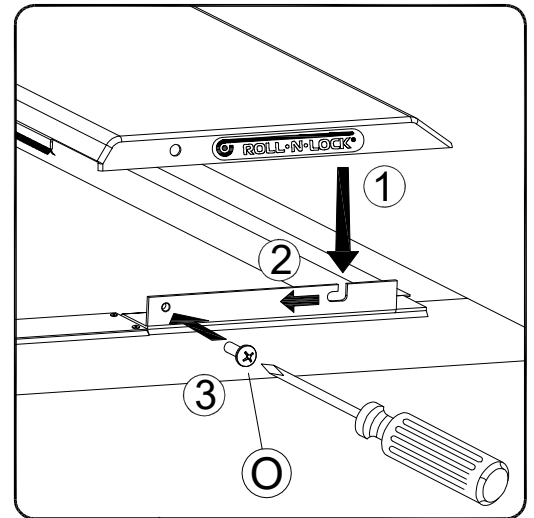



13

To open cover pull back on the handle, turn the lock (1 & 2) to 10 o'clock and with a slight push let the cover retract into the housing while holding onto the pull strap.

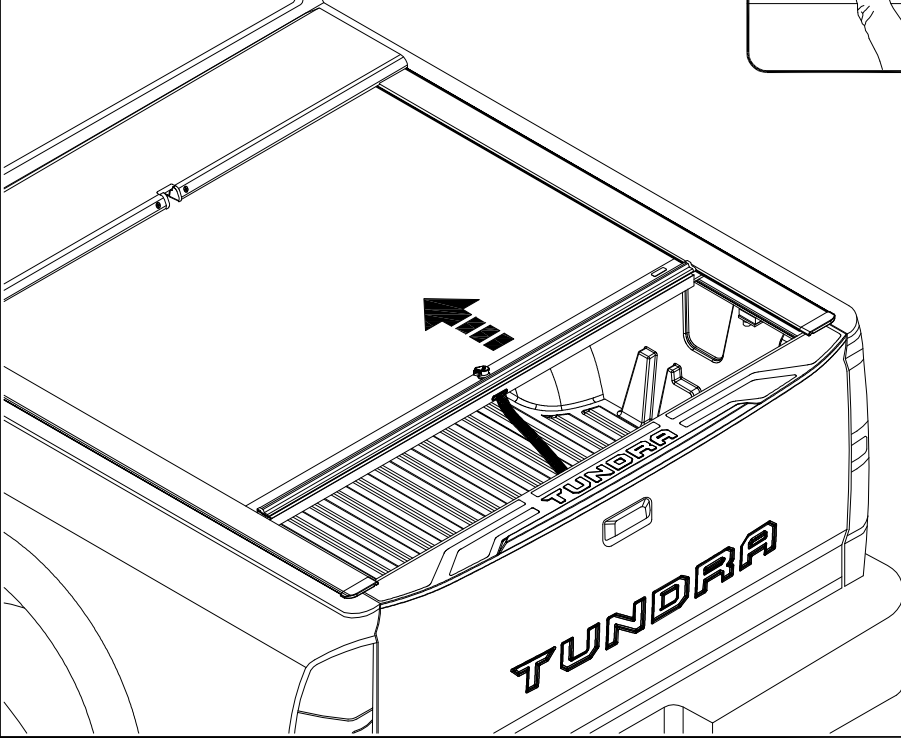
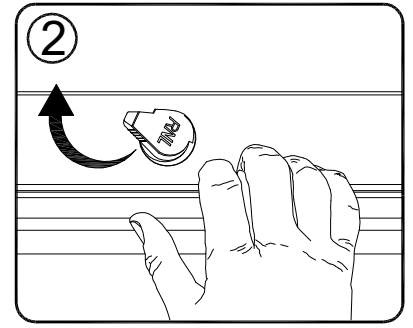
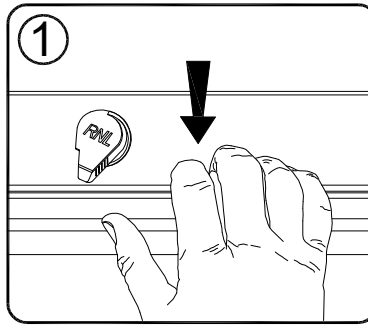

14

Attach the cargo shield (C) with the slots at the bottom of the housing using two black rubber washers (N) and two 1/4-20 x 3/8" screws (M) on driver and passenger side.

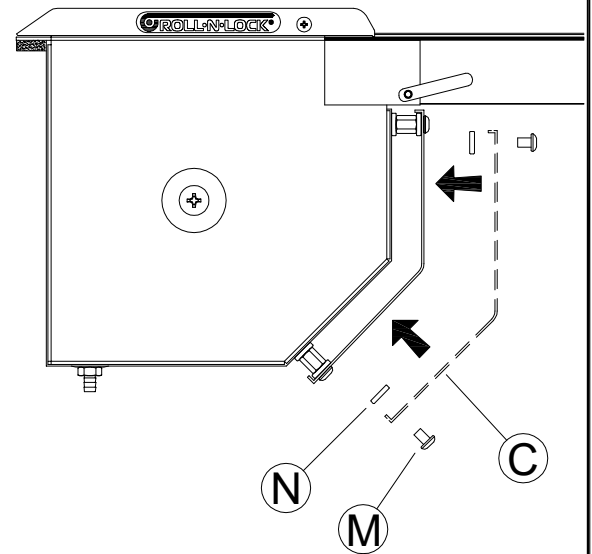
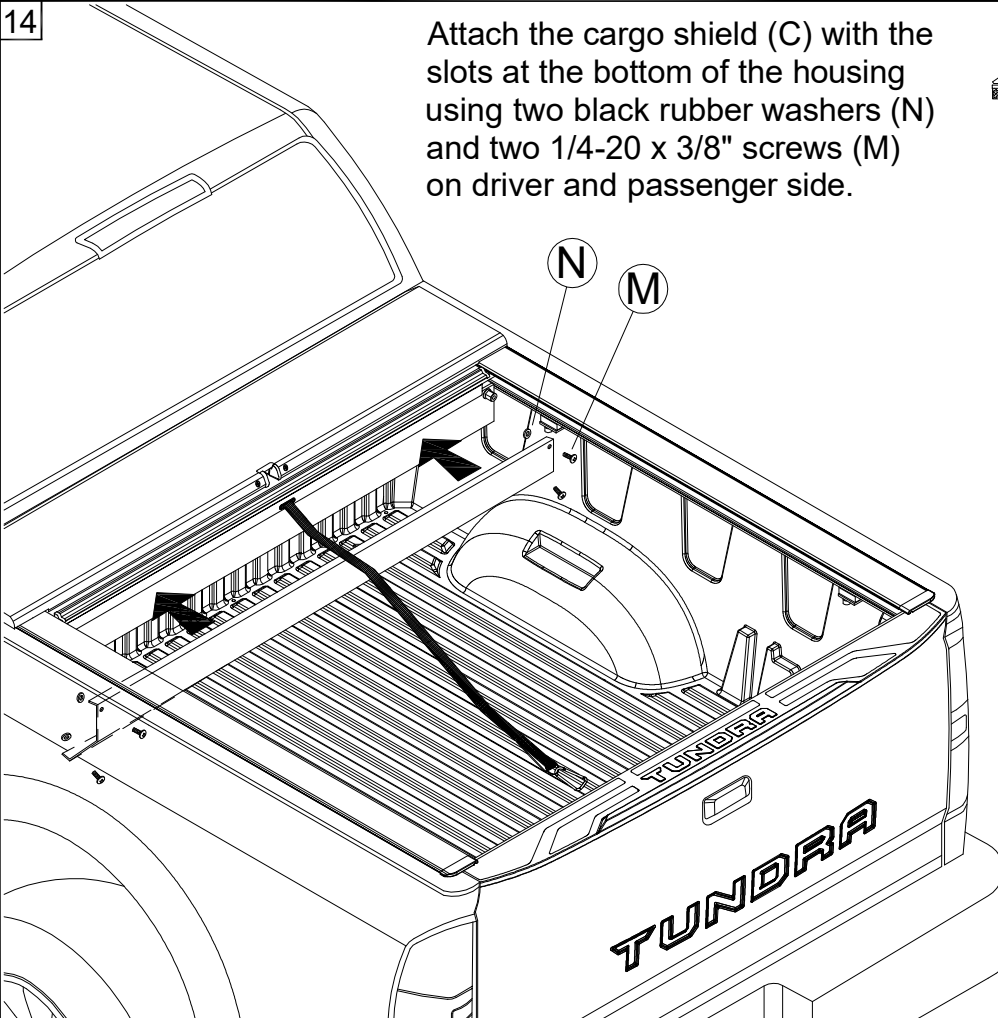

15

Insert one end of the drain tube (D) through the drilled 1/2" hole and feed towards the ground, insert the other end onto the housing fitting.

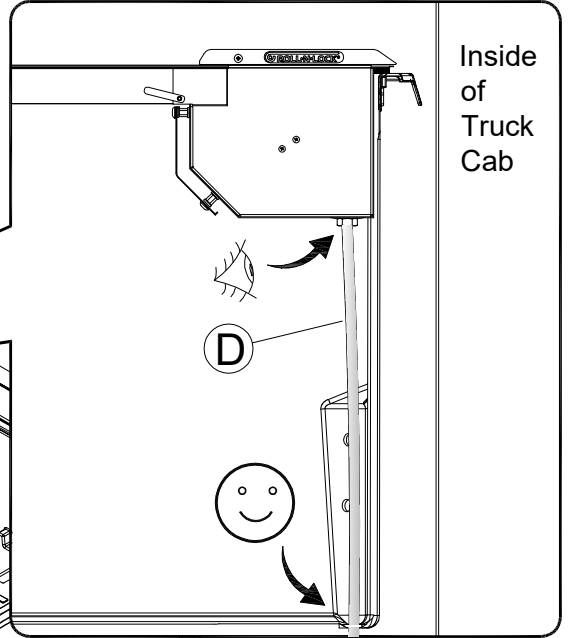
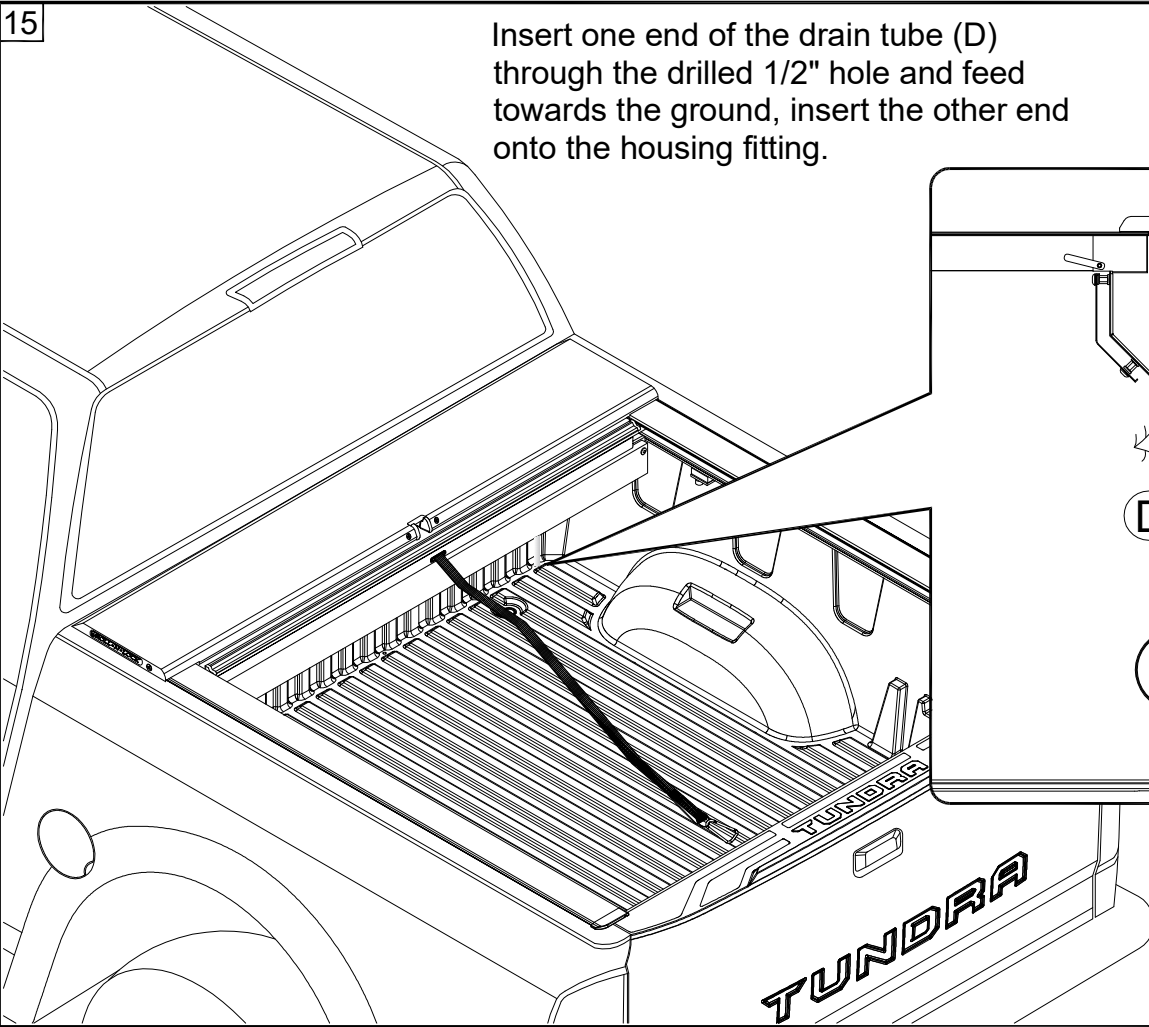

16

Attach pull-strap to the truck.

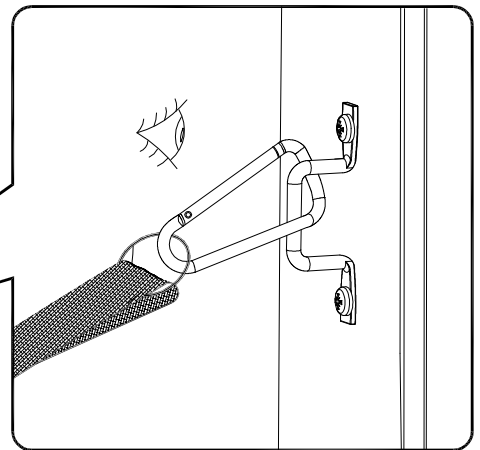
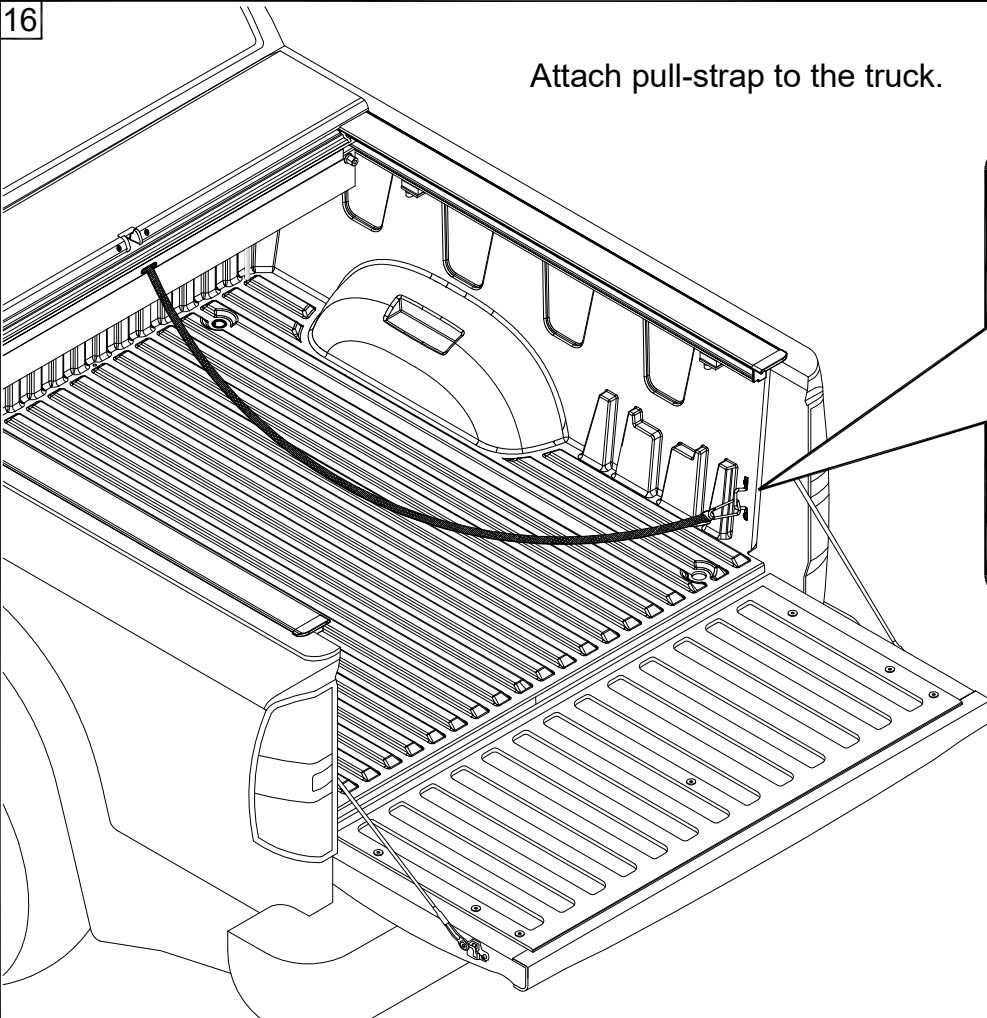

# To the Installer

Cover is hard to pull or retract.



Spray 303<sup>®</sup> on a rag and wipe the top gasket in the track back and forth.

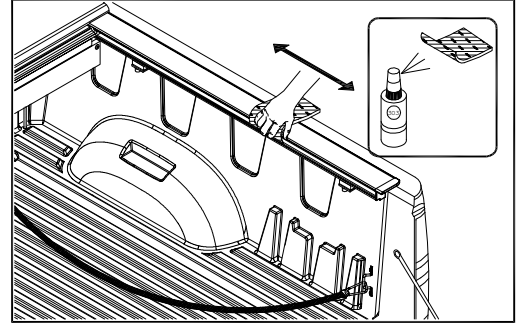

Cover does not latch.



Check Track to Track measurement.

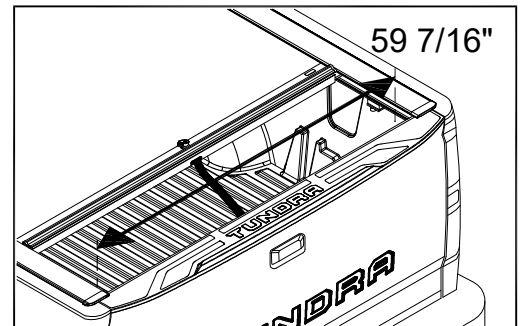

Cover does not reach the tailgate.



Make sure tracks are back against tailgate.

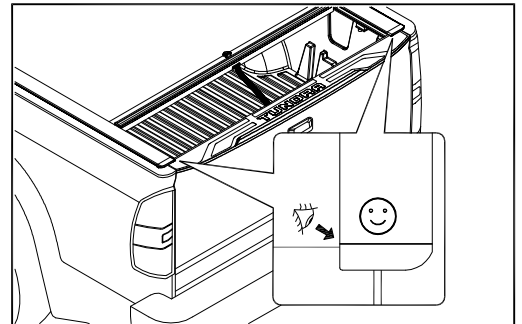

Tracks sit too high or too low.



Use shims under track clamps to adjust height of track.

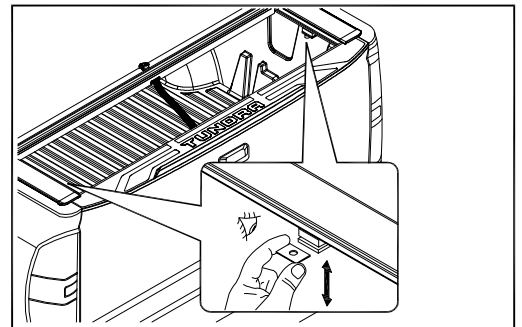

**ROLL-N-LOCK<sup>®</sup>**

Any questions please call Customer Service at 800-952-7655

or email [customerservice@rollnlock.com](mailto:customerservice@rollnlock.com)



# 3-YEAR LIMITED WARRANTY\*

**\*5-YEAR LIMITED WARRANTY ON E-SERIES COVERS**

## [www.rollnlock.com/warranty-information](http://www.rollnlock.com/warranty-information)

This limited warranty is extended by ROLL-N-LOCK Corporation, a Florida corporation, with its principal office at 915 S. Dixie Highway, E., Pompano Beach, Florida ("ROLL-N-LOCK"), to the original purchaser of a ROLL-N-LOCK® truck bed cover or cargo management device. ROLL-N-LOCK warrants its products, when purchased directly or from an authorized reseller, to be free from manufacturer's defects for a period of three (3) years from the date of purchase on A and M Series covers -- five (5) years from date of purchase on E-Series covers. During this period, ROLL-N-LOCK, or its authorized dealer, will repair or replace at no expense to the limited warranty holder, any part found to be defective as a result of the manufacturing process, subject to the limitations and exclusions below (See HOW TO MAKE A CLAIM below). Labor charges associated with removing or reinstalling the product and parts are not covered with this warranty. ROLL-N-LOCK warrants only against defects that arise as a result of normal use of the product in normal environmental conditions. ROLL-N-LOCK does not warrant against the following: (a) improper installation, including, but not limited to, installations performed not in accordance with installation instructions and warning labels; (b) extreme environmental conditions, including, but not limited to, temperatures below negative thirty degrees Fahrenheit (-30°F) or above one hundred-twenty degrees Fahrenheit (120°F); (c) water intrusion, including, but not limited to, leaks as a result of normal use; (d) misuse, abuse, modification, tampering or alteration; (e) improper maintenance; (f) operation outside of the product specifications; (g) normal wear and tear, cosmetic damages or fading or deterioration of the finish caused by exposure to sunlight or chemicals and/or other unusual environmental conditions; (h) negligence; or (i) accidents, flood, fire, earthquake or other acts of God. This warranty does not extend in any respect to accessories or parts not produced by ROLL-N-LOCK and shall not extend to any consequential or incidental damages. This warranty is expressly in lieu of all other warranties expressed or implied, including the warranties of merchantability and fitness for a particular purpose and of all other obligations or liabilities on the part of ROLL-N-LOCK. ROLL-N-LOCK neither assumes nor authorizes any other person to assume for it any other liability in connection with the sale of its products. The warranty expires if the product is removed from the original vehicle or if the original vehicle is transferred to another owner. The warranty is not transferable from the original purchaser. Some states do not allow the exclusion or limitation of incidental or consequential damages, or limits on implied warranties, therefore the above limitations may not apply to you. This warranty gives you specific legal rights and you may also have other rights which vary from state to state. ROLL-N-LOCK does not warrant any products purchased from unauthorized resellers or any products whose serial number has been removed or defaced. For a complete list of ROLL-N-LOCK authorized dealers, please visit ROLL-N-LOCK's website at <http://rollnlock.com> and click on the "Find a Dealer" tab.

## HOW TO MAKE A CLAIM

For products purchased from a brick and mortar dealer, the party claiming must notify the dealer from whom the product was purchased of the defect or malfunction. The dealer will inspect the product and consult ROLL-N-LOCK to be covered by its warranty. ROLL-N-LOCK will send, at no cost to the warranty holder (including freight expense within the continental U.S.A.), the replacement part or parts necessary to correct the defect. If the problem is determined to be caused by improper installation by the dealer, the dealer will, in accordance with his obligation to adhere to ROLL-N-LOCK's authorized dealer warranty policy, immediately rectify the problem. For products purchased from ROLL-N-LOCK directly, a ROLL-N-LOCK internet dealer or any other authorized outlet that excluded the service of installation, and the warranty holder performed the installation on a do-it-yourself basis, the warranty holder may, at ROLL-N-LOCK's option, be required to return the defective parts, properly packaged and at the warranty holder's expense, to ROLL-N-LOCK's warranty department at the address below. The warranty holder should include a product I.D. number and a brief description of the problem. If the part or parts are found to be defective, the replacement part or parts will be immediately returned to the warranty holder at ROLL-N-LOCK's expense (limited to the continental U.S.A.). If the warranty holder requires assistance, he may call ROLL-N-LOCK directly at 1-800-952-7655. ROLL-N-LOCK maintains the highest possible standards of manufacturing and quality control. Accordingly, it expects its dealers to adhere to a similar standard when installing its products and upholding this warranty. If you believe you have a defective ROLL-N-LOCK product and encounter any difficulty obtaining satisfaction, please contact ROLL-N-LOCK customer service by telephone at 1-800-952-7655 or by email at [info@rollnlock.com](mailto:info@rollnlock.com).

