

E-SERIES

STANDARD AND XT SERIES

2015+ Ford F-150 2017+ Ford F-250 & F-350 Super Duty INSTALLATION SHEET

Any damaged or missing parts?

Parts will be shipped to you directly.

Call 1-800-952-7655 Mon-Fri 8am - 5pm EST

or email info@rollnlock.com

NOTE: Installation is the same for both standard track and XT Series track

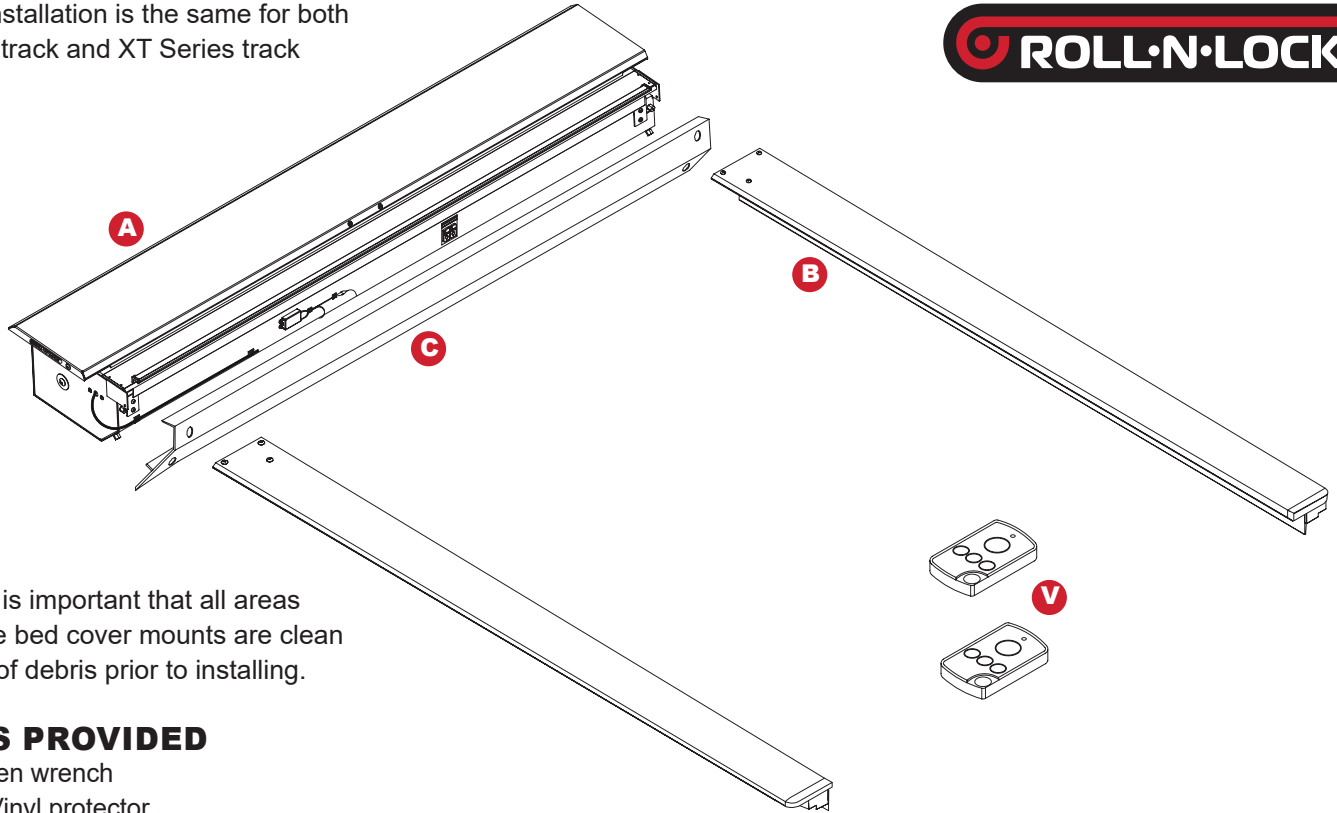

NOTE: It is important that all areas where the bed cover mounts are clean and free of debris prior to installing.

TOOLS PROVIDED

- 1/4" Allen wrench
- 303® Vinyl protector

TOOLS REQUIRED

- Jig saw
- 1/2" drill bit
- Drill with Phillips head
- Phillips screwdriver
- 7/16" wrench
- Tape measure
- Utility knife

PARTS INCLUDED IN YOUR KIT

- A** 1x Housing
- B** 2x Track
- C** 1x Cargo shield
- D** 2x Drain tube
- E** 2x Track angle
- F** 2x Thread tang
- G** 2x 1/4-20x1 1/4" Hex bolt
- H** 2x 1/4" Flat washer
- I** 4x 5/16" Socket cap screw (6x 6'7"ft Bed)
- J** 6x 5/16" Lock washer (8x 6'7"ft Bed)
- K** 2x 5/16x3/4" Socket cap screw
- L** 4x Bed clamp (6x 6'7"ft Bed)
- M** 2x Track angle shim
- N** 6x #10-24x3/4" Screw
- O** 6x Cargo nuts
- P** 4x 1/4-20x3/8" Screw
- Q** 4x Black rubber washer
- R** 2x 1/4-20 Lid screw (Taped to lid)
- S** 2x 5/16" Flat washer
- T** 1x Override cable
- U** 1x Power wire/connectors
*Which includes: 1x Fuse holder
1x Power wire
10x Zip ties*
- V** 2x Remotes (Taped to housing)

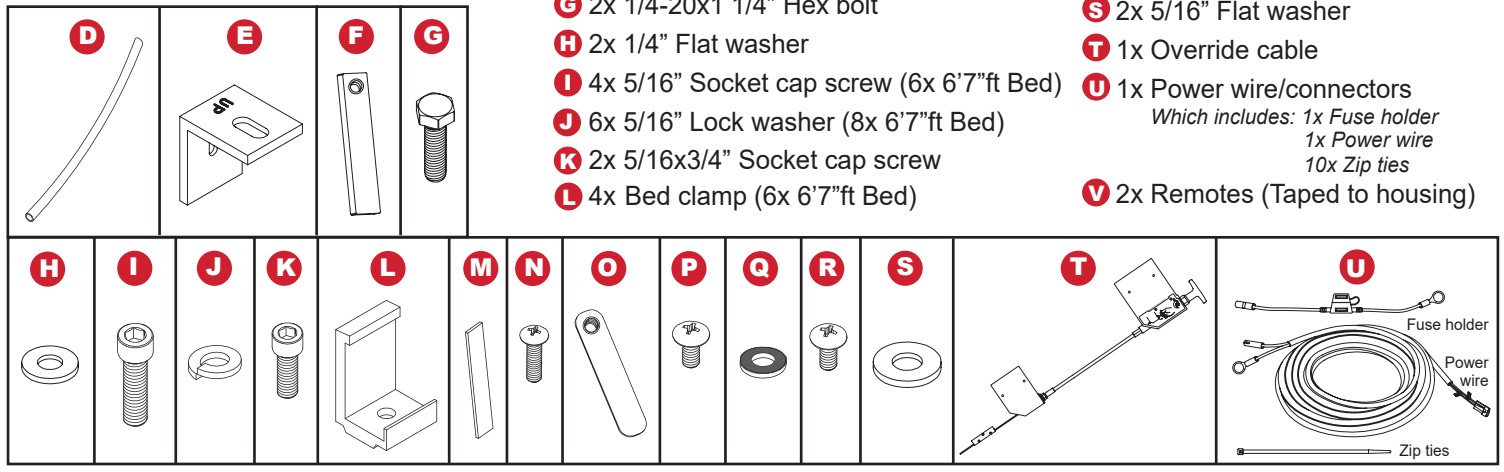

1A If there is No plastic bedliner proceed with step 1C. Remove the bedliner. 1. Using a tape measure with the measurements given, cut across the bulkhead (cab) from passenger to driver side. 2. Use the measurements on the tailgate end to cut out both driver and passenger side pieces. 3. Then use a jig saw to cut the liner parts out. Discard cut parts. 4. Drill (5) 1/2" holes where indicated. Reinstall the bedliner.

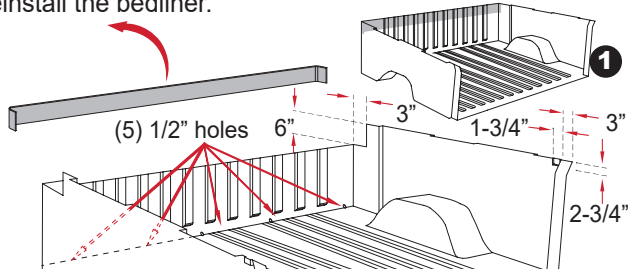

1B FOR SUPER DUTY ONLY - If there is No plastic bedliner proceed with step 1C. Like step (1A) using a tape measure follow the measurements in that step and mark on bedliner where to cut. Then use a jig saw to cut the liner parts out. In step (1A) the measurement is 3-3/4" (1) instead of 3". Drill (5) 1/2" holes where indicated. Repeat on driver side. Then mark on tailgate protector (2) where to cut and take it off tailgate to cut it. Discard cut parts. Replace tailgate protector.

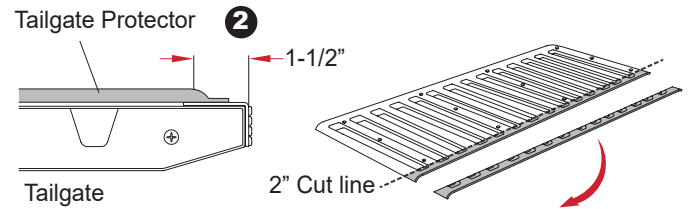

1C Drill 1/2" hole through plug at bulkhead as shown (1) on driver and passenger side using a 1/2" drill bit (2). DO NOT drill through the truck cab (3). **Note:** Rust protection should be used on the holes you drilled.

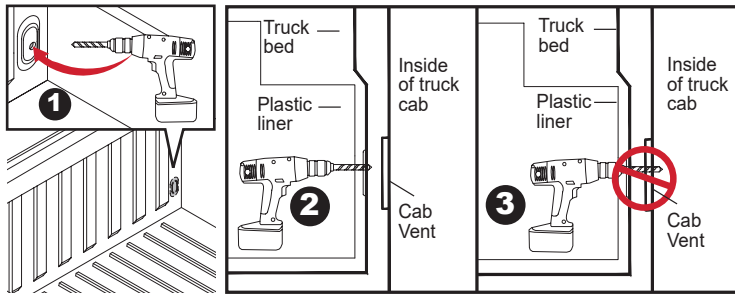

2 Feed end of power wire (U) through the side panel to the ground on driver side. Leave 2' feet of power wire in the truck bed.

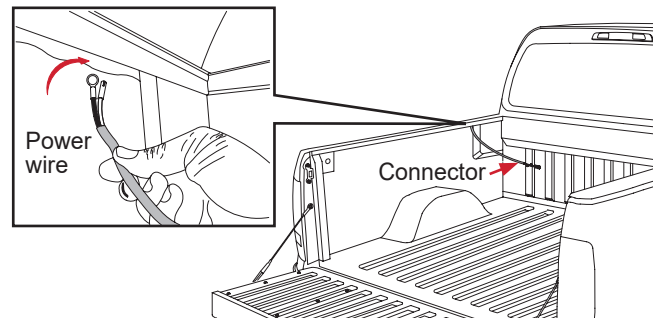

3 Feed the power wire (U) under the truck securing to an existing wire harness leading to the battery with supplied zip ties (U).

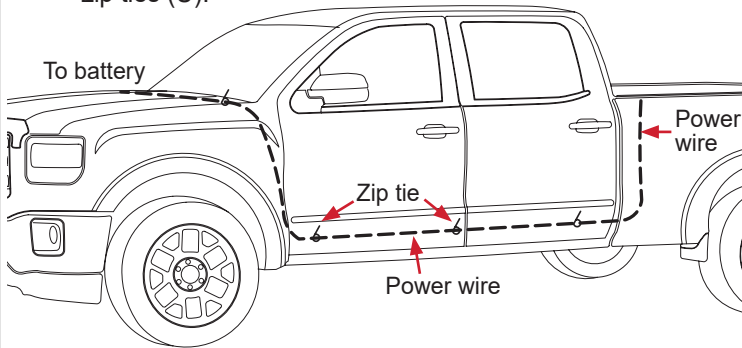

4 Connect the red fuse holder (1) to the white wire (2).

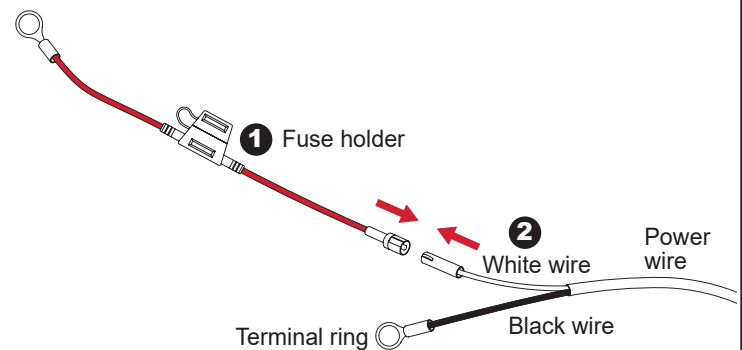

5 Connect the red fuse holder ring to positive terminal (1) and the black wire/terminal ring to negative terminal (2) of battery.

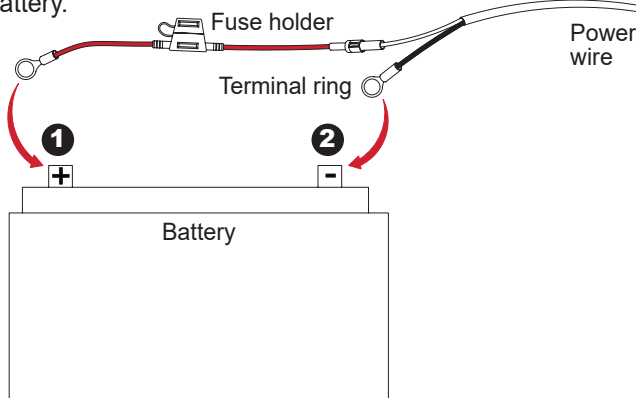

6 Center the housing (A) between the bed rails, and up against the bulkhead on driver and passenger side.

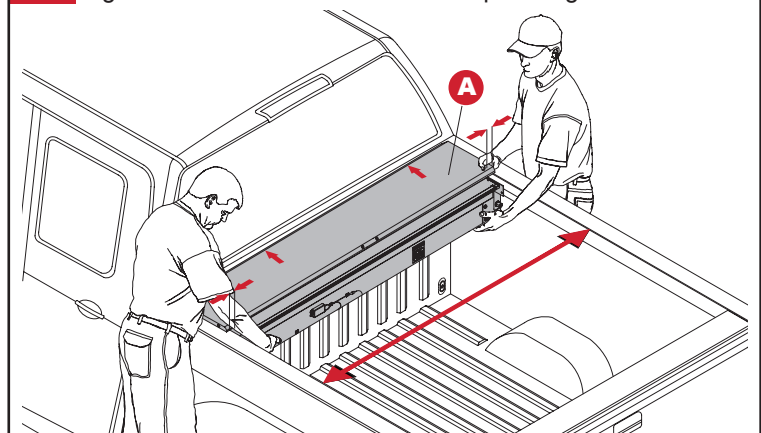

7 Remove lid from housing (A) by pushing toward cab (1) and up (2) on driver and passenger side.

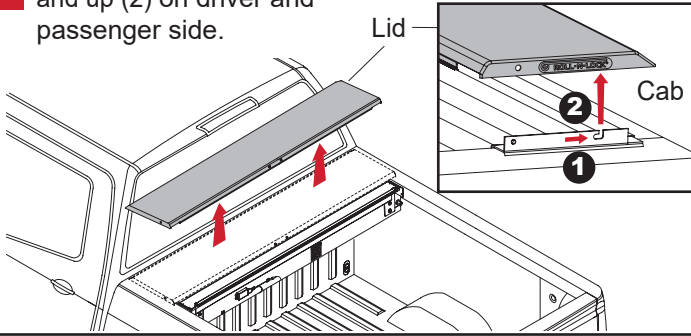

8 Assemble the track angle (E) to the thread tang (F) using a 1/4-20 x 1 1/4" bolt (G), flat washer (H). Insert track angle (E) in hole (1) and loosely attach on driver and passenger side.

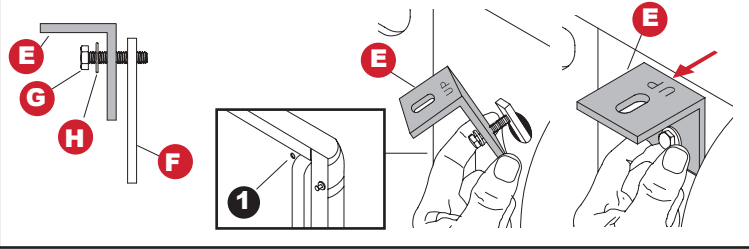

9 (1) Align tracks (B) onto housing stem. (2) Make sure the edge of the tracks butt up against housing on driver and passenger side. (3) **Note: Do Not** remove the piece of cardboard until tracks are installed.

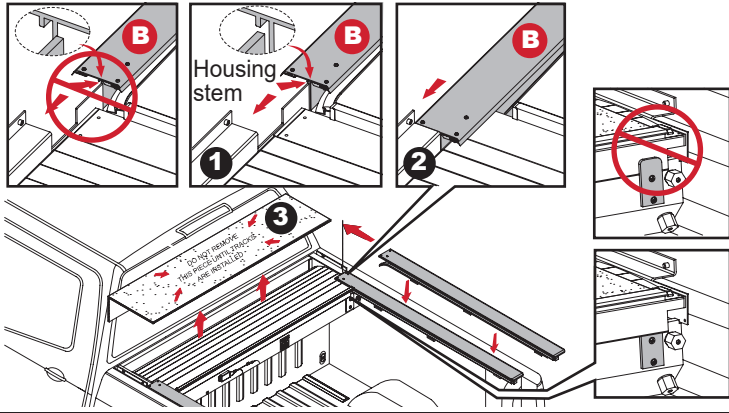

10 (1) Loosely attach bed clamps (L) to the pre-installed track clamps using 5/16" socket cap screw (I) and 5/16" lock washer (J) on driver and passenger side. (2) Loosely attach the track angle (E) to the pre-installed track clamps with 5/16" flat washer (S), 5/16" lock washer (J) and 5/16x3/4" socket cap screw (K).

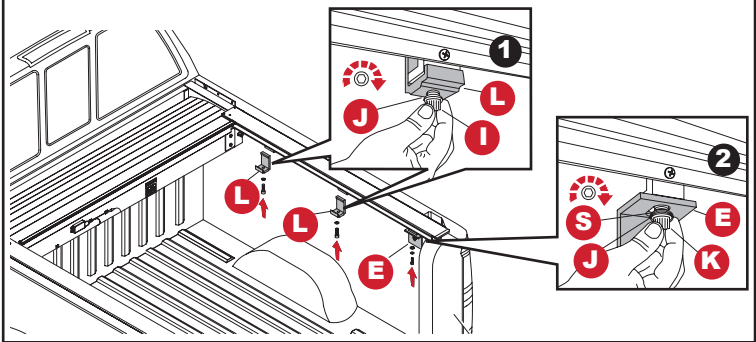

11 Secure tracks (B) to housing stem (1) on driver and passenger side using cargo nut (O) and #10-24x3/4" screw (N) using a Phillips screwdriver (2).

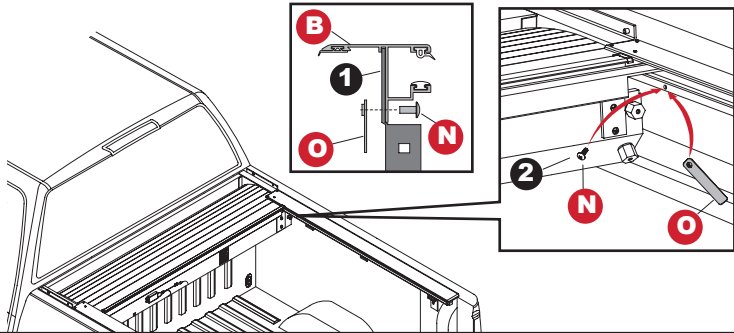

12 FOR SUPER DUTY ONLY - Notch lip 3/4" on tailgate flush on each end.

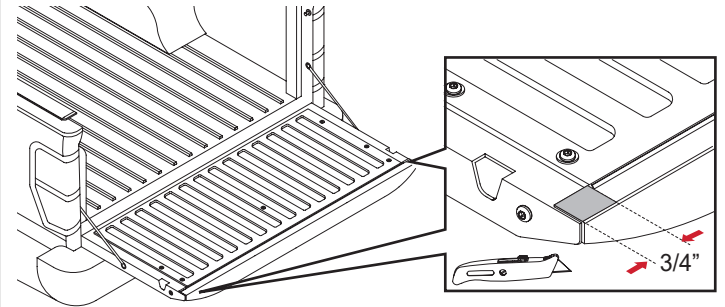

13 Close tailgate, shift the housing (A) back so the end of the tracks (B) are up against the tailgate on driver and passenger side.

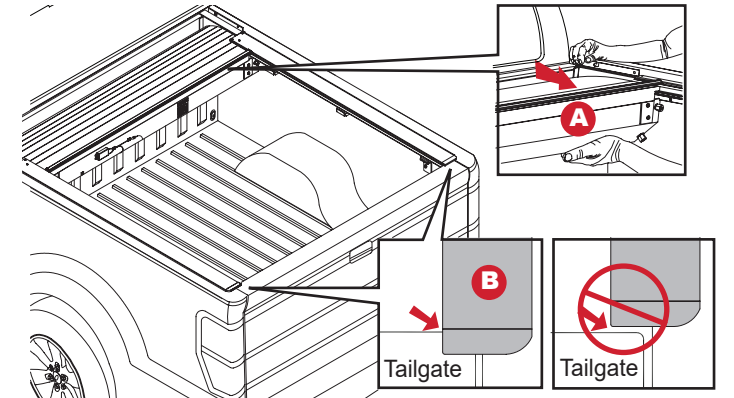

14 Important to check track to track inside dimension, otherwise the cover will not latch properly on driver and passenger side.

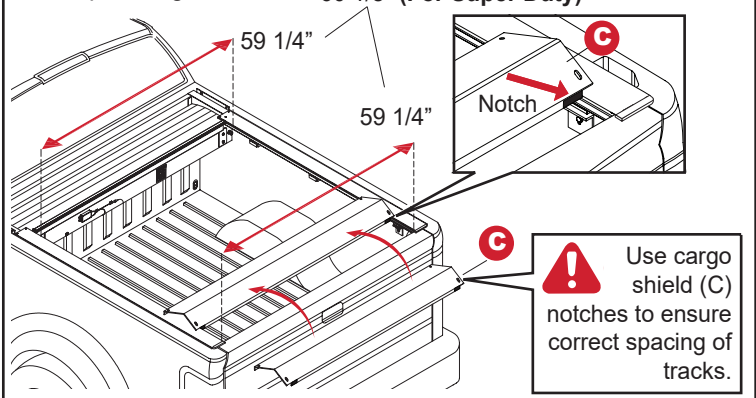

15 Once tracks (B) are correctly spaced and adjusted to the correct height, tighten back clamp (E) with fastener (K) using 1/4" Allen wrench (1) and fastener (G) using a 7/16" wrench (2). You can use shim(s) (M) to align the track to 90° position on driver and passenger side.

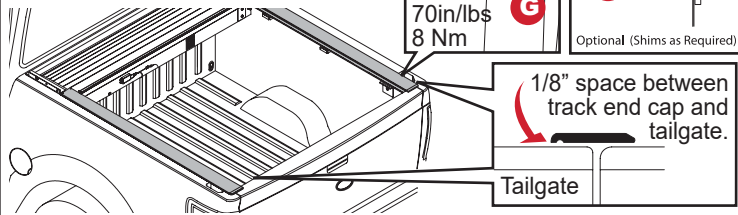

16 Tighten bed clamps (L) to the pre-installed track clamps using a 1/4" Allen wrench on driver and passenger side. **Note:** When tight there may be a gap between the clamps, **do not over-tighten.**

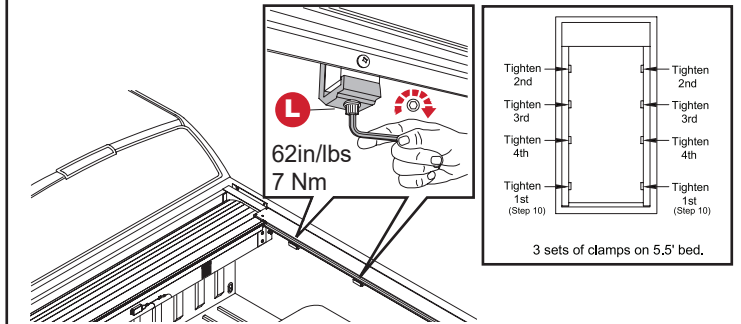

17 Replace lid on housing (A) by lining up the pin with the slot and pushing down (1) and toward tailgate (2) on driver and passenger side. Then install the 1/4" lid screws (R) with a Phillips screwdriver (3) on driver and passenger side.

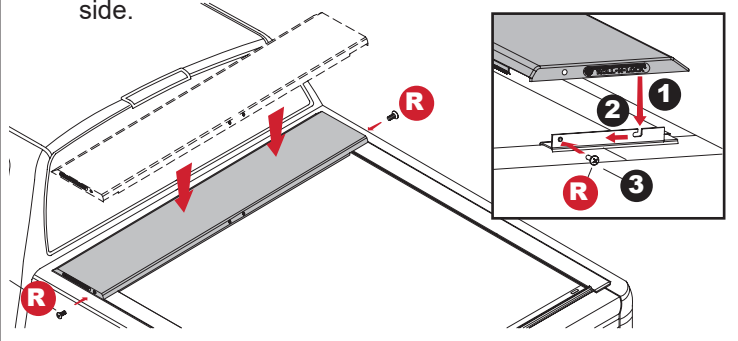

18 Insert one end of the drain tube (D) through the 1/2" hole that was drilled through plugs (1) in step (1C) and insert the other end onto the housing fitting. Make sure the drain tubes (D) are NOT aligned with or through the cab vents (2) on driver and passenger side.

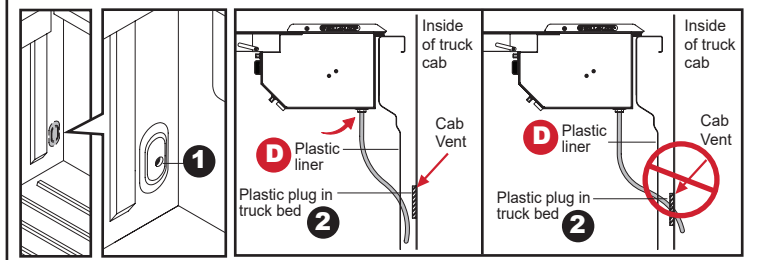

19 POWERING THE UNIT

A

Unwrap light wires (1) from motor wire (2). You can throw away the tie (3) holding the wires together.

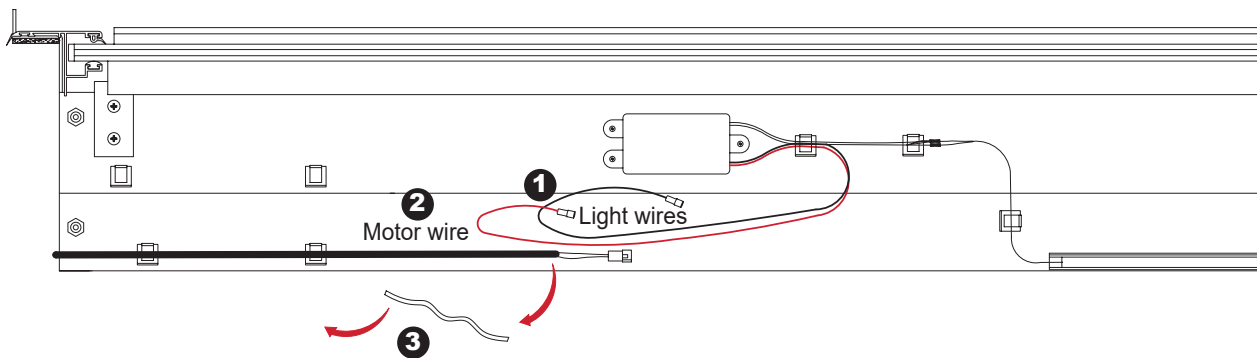

B

Bring power wire (1) around and attach onto cable mounting clips (2) in front of the unit.

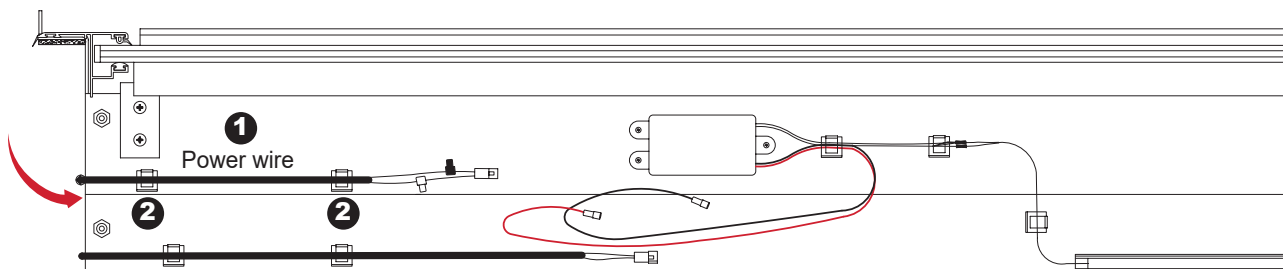

C

Plug motor wire connector (1) into power wire connector (2).

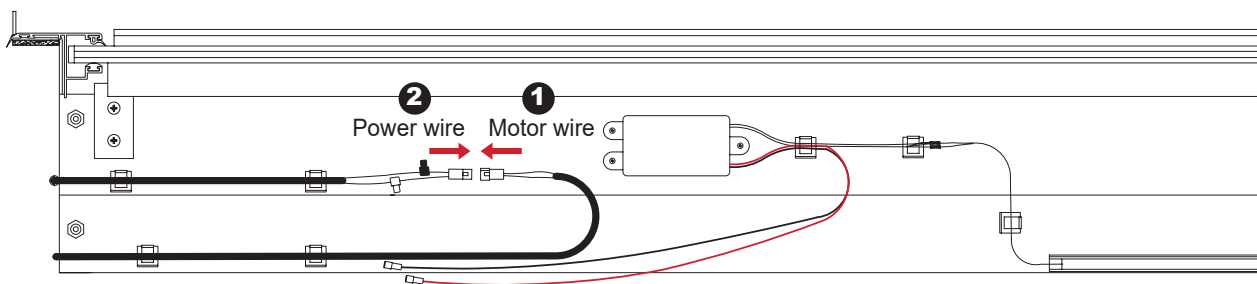

D

Plug black light wire connector (1) into black power wire connector and plug red light wire connector (2) into white power wire connector.

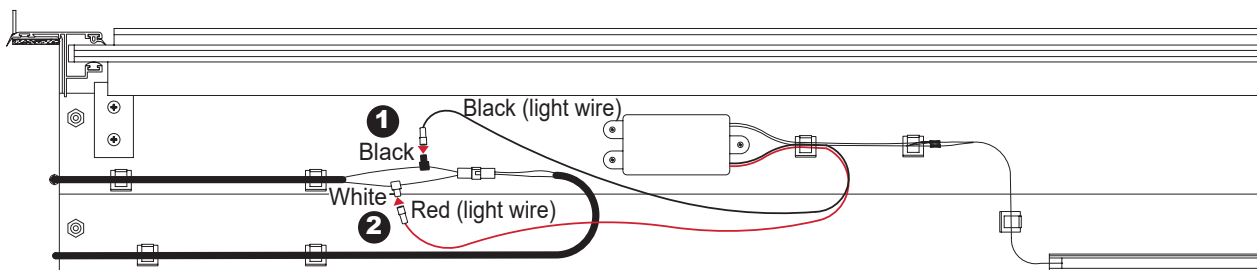

E

Position motor wire connection.

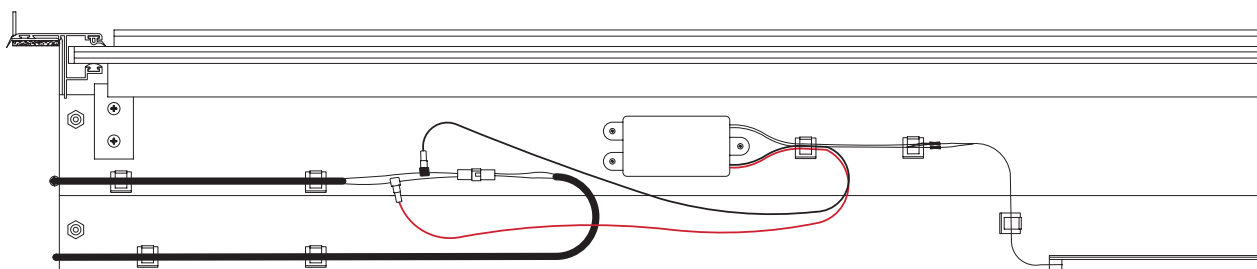

20

Remove remotes (V) from housing.

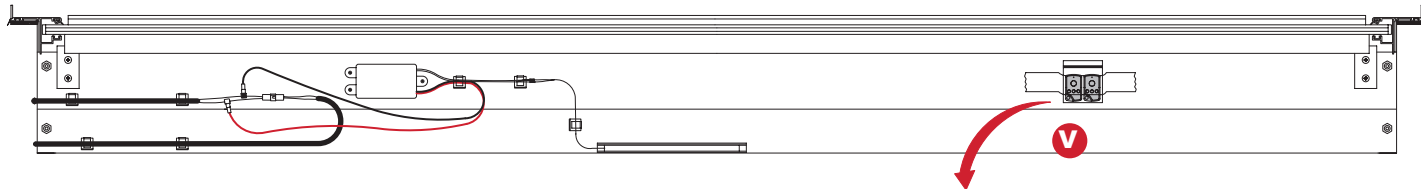
**OPERATING THE SYSTEM**

- Push the large button to run cover.
- Push the large button to stop the cover
- Cover will stop automatically at tailgate and housing.

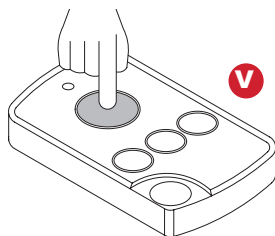

- Push the small left button to turn light on.
- Push the small left button to turn light off.
- Light will automatically turn off in three minutes.

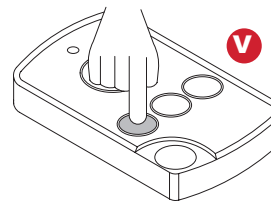
**21**

Attach cargo shield (C) with the slots at the bottom of the housing (A) using two black rubber washers (Q) and two 1/4-20x3/8" screws (P) on driver and passenger side.

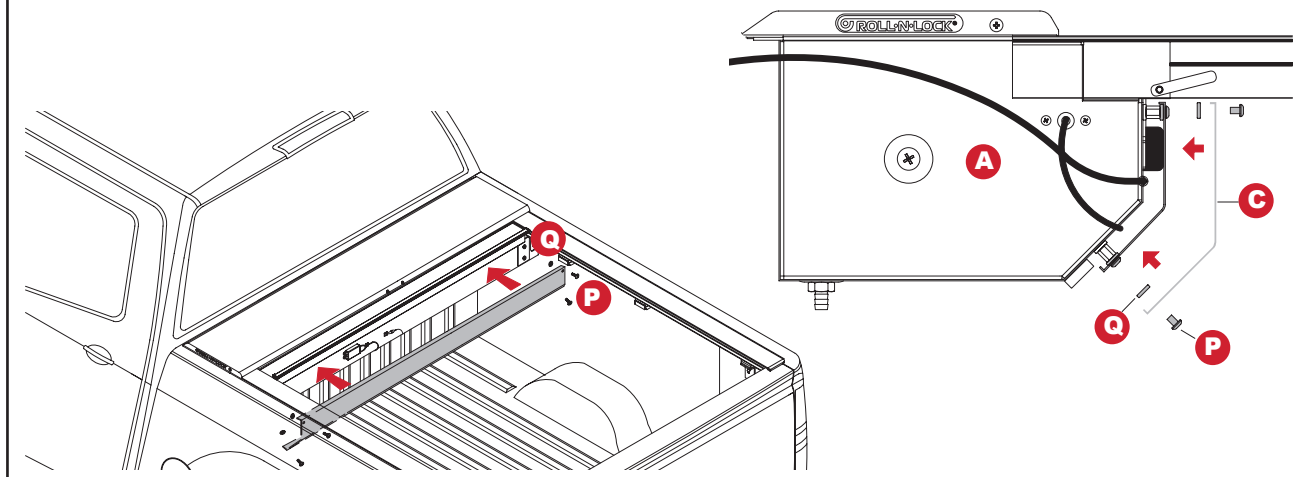

Override cable (T) installation.

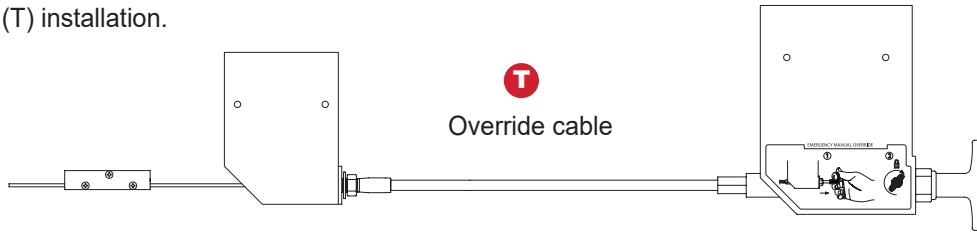

Attach small bracket (1) through the slotted holes using two cargo nuts (O) and two 10-24 screws (N) towards the front of the track.

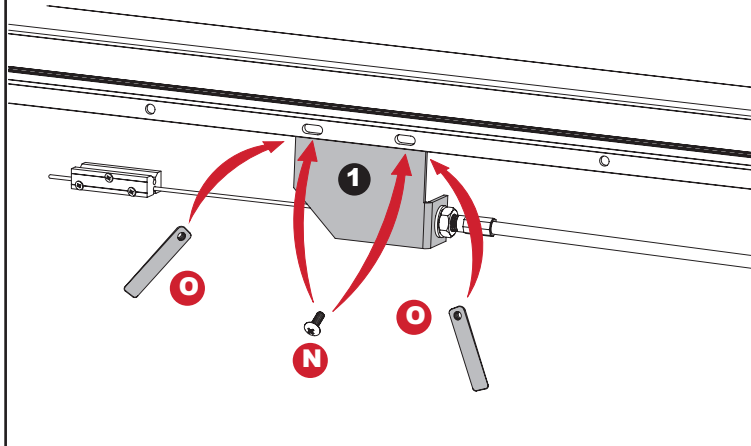

Attach large bracket (2) through the slotted holes using two cargo nuts (O) and two 10-24 screws (N) towards the back of the track.

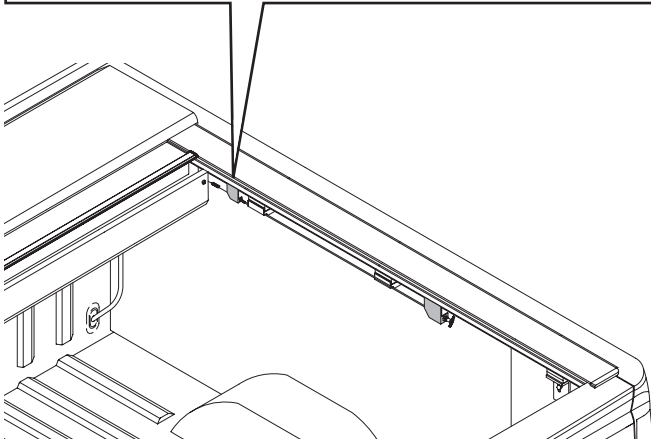
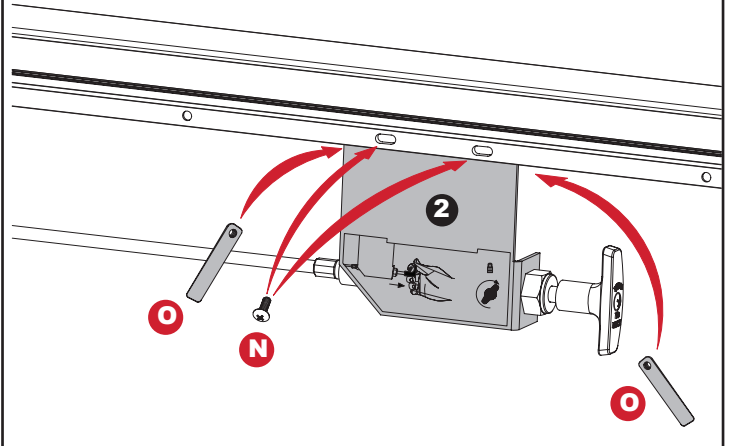

Loosen top screw (3), pull the soft cable from the housing taught through the cable coupler and tighten screw.

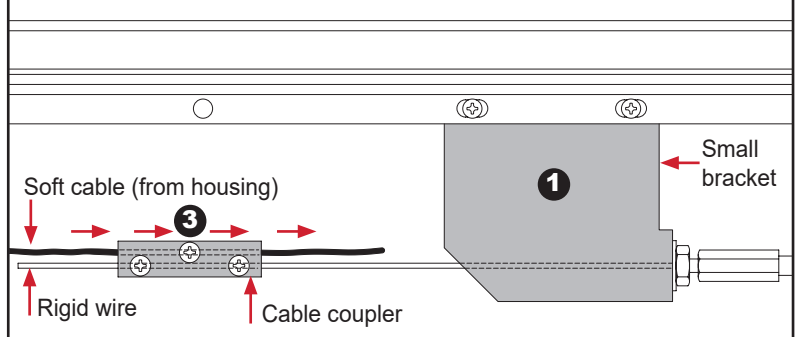

OPERATING THE OVERRIDE - Use only when the cover is not operating remotely.

(1) Pull the lever and (2) turn to lock in place, the cover will operate manually. To go back using the cover remotely, unlock the lever and push back to lock cover.

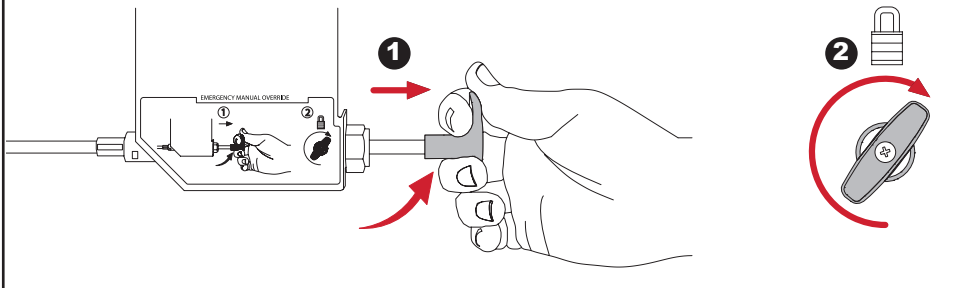

Key brackets (1) into slot on the back of the track (B).

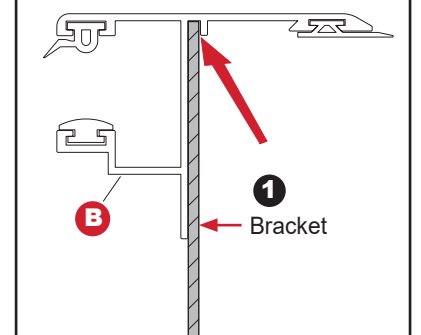

IMPORTANT NOTICE

This bed cover may retract to the full open position very quickly resulting in any objects placed on top of the bed cover to fall off the bed cover or become trapped inside of the bed cover carrier. Do not place ANY objects on top of the bed cover when attempting to close. Failure to follow the instruction may result in damage to your vehicle, belongings or bed cover. To avoid injury keep all body parts clear of the bed cover and carrier when opening.

LIMITED WARRANTY

WARRANTY COVERAGE

This truck bed cover is warrantied against defects in materials or workmanship as follows. This warranty is void if the product has been damaged in an accident, or due to neglect, unforeseeable use, improper installation, improper servicing, or other cause not arising out of defects in material or workmanship.

This truck bed cover carries a limited warranty for five (5) years from the original date of purchase, subject to the terms below.

WARRANTY IS NOT TRANSFERABLE

The warranty is to the initial consumer purchasing the truck bed cover and it is not transferrable to a subsequent end user. Proof of purchase may be required to enforce these warranty rights.

WARRANTY CONDITIONS

Failure to follow these care and use instructions will void the warranty:

- Clean with mild automotive soap and water only. Do not use any strong chemicals or cleaners. Lubrication of the rails with silicone or petroleum-based products will void the warranty.
- Cargo must be secured at all points when the vehicle is in motion. Failure to adequately secure the cover or tether strap can result in damage and will void the warranty.
- Check all clamps and retention mechanisms for tightness after a week of driving following installation (or re-installation) of the cover and periodically thereafter.
- Before opening, the cover must be free of all foreign materials including snow and ice.
- Do NOT tow your vehicle from the rear with the cover on your vehicle. If towing from the rear is required, the cover MUST be removed from the vehicle and properly stored.

WARRANTY PERFORMANCE

If all warranty conditions are met, a defective truck bed cover or hardware component will either be repaired or replaced (at our option). We reserve the right, for any warranty, to substitute a newer model or bed cover having a similar form and function, to offer a warranty discount on an entire replacement system, and/or provide remedies other than those mentioned in this document.

WARRANTY RETURN

A Return Material Authorization number must be obtained from our Customer Service Department prior to returning any product. We may require the original item to be returned postage prepaid for final determination. Shipping charges will apply for any repair or replacement. Other than postage or shipping charges, no charge will be made for repair or replacement under this warranty.

This warranty gives you specific legal rights. As a consumer, you may also have additional rights and remedies under the laws of your state.

Register online at <https://rollinlock.com/warranty-registration>

REGISTER
YOUR
WARRANTY
ONLINE



COVER CARE AND MAINTENANCE

Hard Tops

Clean with mild automotive soap and water only. Do NOT use any strong chemicals or cleaners. Use of wax or polish is not recommended.

Maintenance

It is recommended that you periodically check that the cover is securely attached to your truck bed. Inspect the clamps and front mounting bolts to ensure they were properly installed and have not come loose or knocked out of adjustment during operation. Covers that are used with high frequency or that are subject to the vibrations and impact from rough roadways can cause the cover to require adjustment.

IMPORTANT: NEVER spray any lubricant into the tracks. **THIS WILL VOID YOUR WARRANTY.** Lubricants, especially silicone or petroleum-based, will attract dirt and debris which will lead to slow operation and will degrade the gaskets over time. If the tracks feel a little 'sticky', you may spray some 303 Aerospace Protectant® inside the track and wipe with a clean rag to remove any dirt or debris that has built up.

Housing Drains

To ensure proper drainage, it is recommended that the canister housing be checked and cleared of any leaves, twigs or other debris that may obstruct the drain tubes.

To remove the lid, first, make sure the Roll-N-Lock cover is fully closed at the tailgate. Remove the Phillips head screw on each side of the lid and slide the lid slightly forward toward the cab to disengage the set pins. Once free, the lid can be lifted and removed from the canister. **DO NOT ALLOW THE COVER TO RETRACT WITH THE LID REMOVED.** This could allow the cover to retract too far into the canister causing damage to the cover.

SAFETY INSTRUCTIONS

- DO NOT place objects on or against the cover or framework.
- DO NOT tie cargo to truck bed cover framework.
- DO NOT operate the vehicle with objects on top of the cover body.
- NEVER allow children or pets to occupy the truck bed while the cover is closed.
- The cover is not airtight. Special care is required to keep cargo clean and dry.
- Tonneau covers won't prevent theft of contents inside the truck box.

TROUBLESHOOTING TIPS

Cover jumps when running.

- Check track connection at housing.

Cover drags running forward and back.

- Spray 303® on a rag and wipe the top gasket in the track.

Cover binds when closing.

- Check track to track measurement.

Track tips up or down.

- Use shim(s) behind bracket to level track.

Cover does not run.

- Check connection at the battery.

Light does not work.

- Check plug-in connection.