



24-C Ford Ranger, Mud Flap Set, Front Mounting Diagram & Instructions GCR414F

IMPORTANT:

The manufacturer is not responsible for negligent use of vehicle with mud flaps installed, including over-tightening of screws and bolts causing damage to vehicle or mud flaps.



TOOLS REQUIRED:



Push Pin
Removal Tool

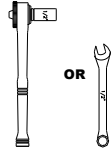

1/4" open or
socket wrench

FLAPS AND BRACKETS

(1) Mud Flap
Driver Side

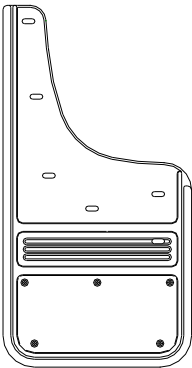

(1) Mud Flap
Passenger Side

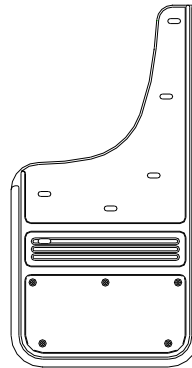

PARTS BAG #770894

a) (8) Sht Mtl Screw
8-18 x 1" SS Blk Oxidized
Part #016055



b) (4) Sht Mtl Screw
8-15 x 1.25" SS Blk Oxidized
Part #016059



c) (10) Washer, Flat
0.203" x 1" SS Blk Oxidized
Part # 018070

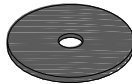

d) (2) Washer, Offset
0.203" x 1.5" SS Blk Oxidized
Part # 018080

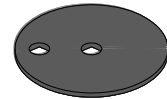

e) (8) Spring Nut, SS
#8, 9/16" Reach
Part #028004

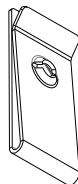

f) (2) Impact Bar Bracket
Universal
Part #770892

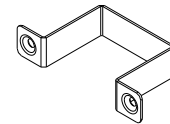

Installation

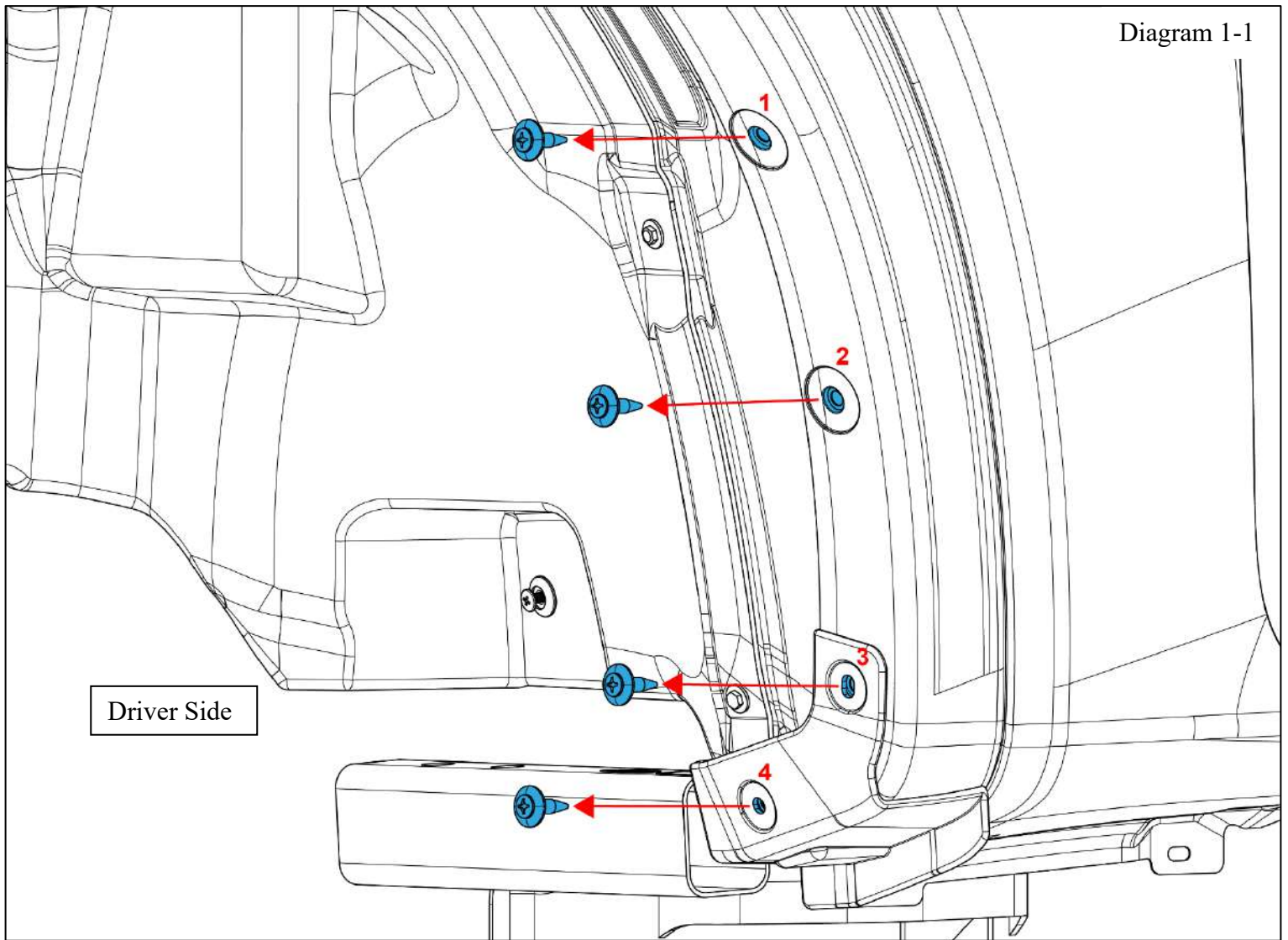

1-1: Remove the 4 factory push pins on the fender. Discard.

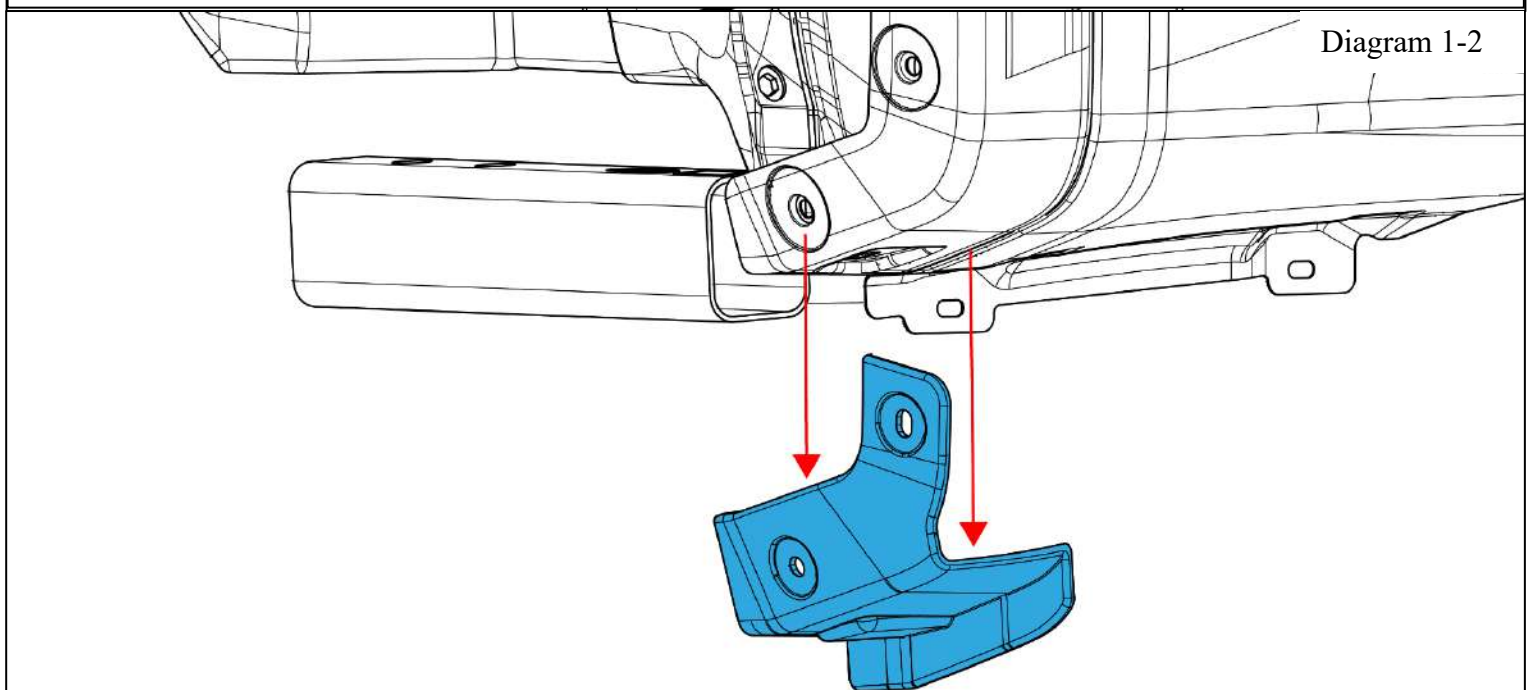

1-2: Remove the factory impingement guard. Discard.

Diagram 2

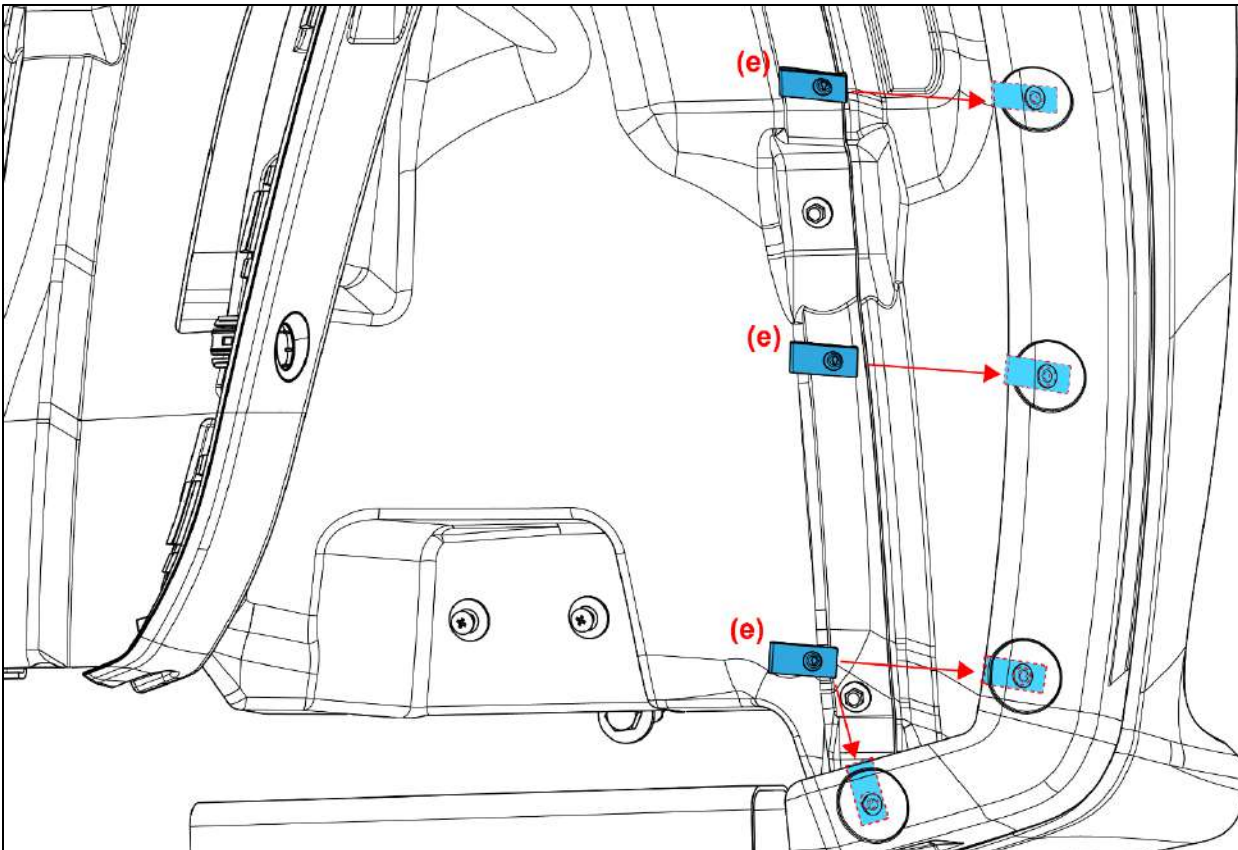

2: Install spring nut (e) on factory holes where push pins were removed. Note that the protruding side of the clip should be facing inward, with the flat side laying between the sheet metal and the plastic wheel lip.
Tip: Ensure that the holes in the spring nut are aligned properly with the factory holes by putting one of the supplied screws through the factory holes and into the spring nut.

Diagram 3

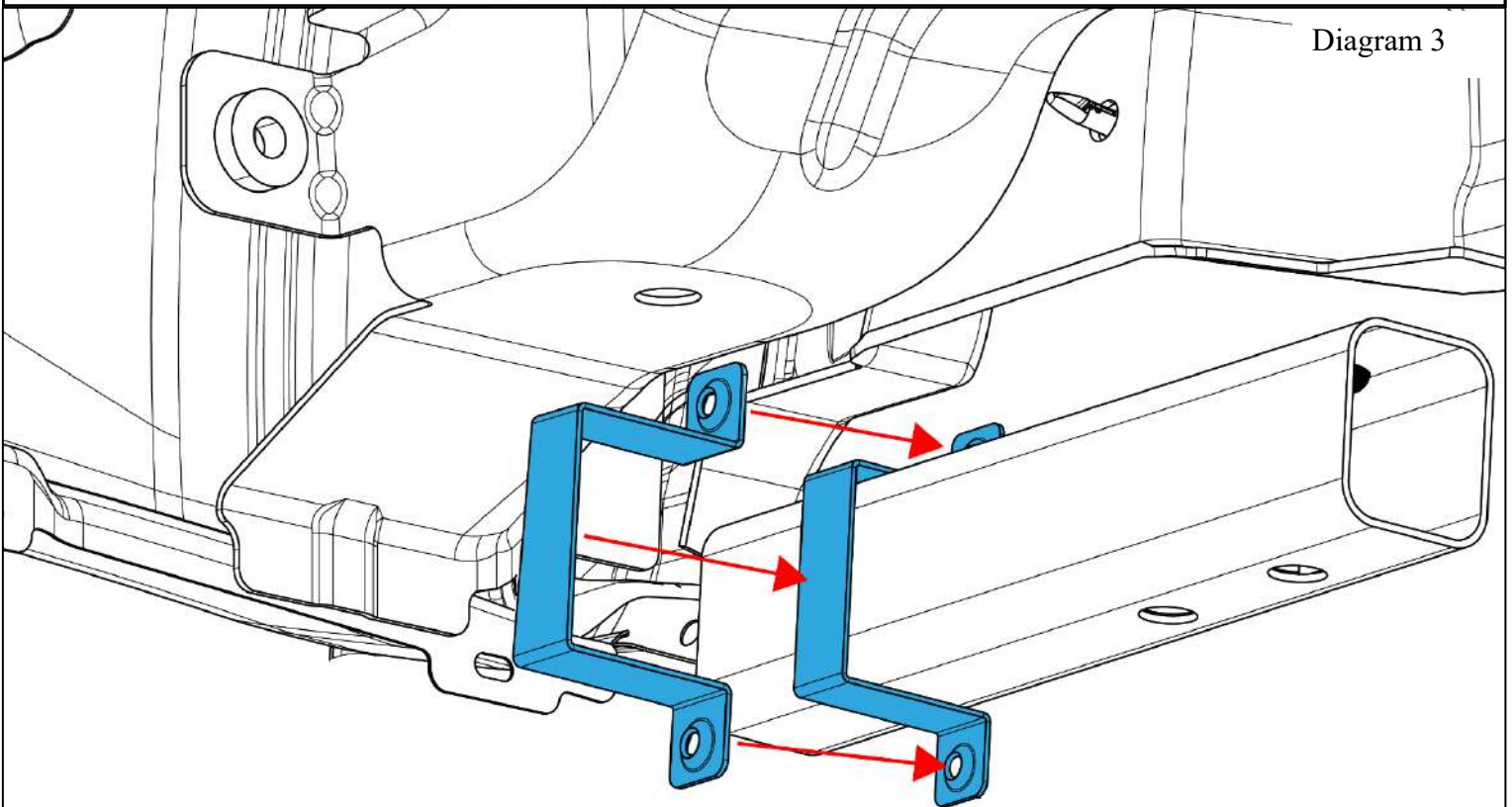

3: Install bracket on impact bar from behind so that the flanges face the tire.

Diagram 4

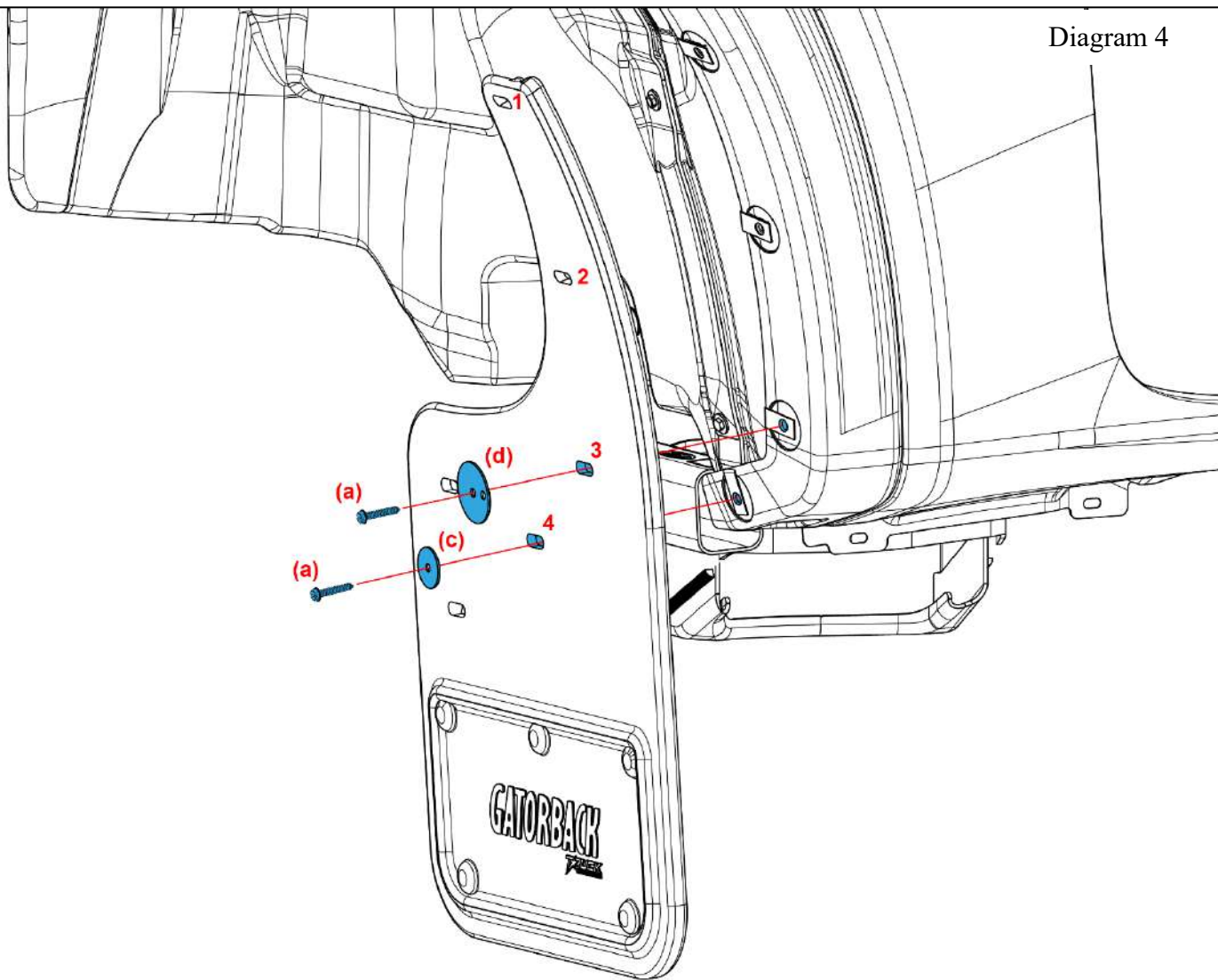

4: Loosely install hardware as shown

Diagram 5

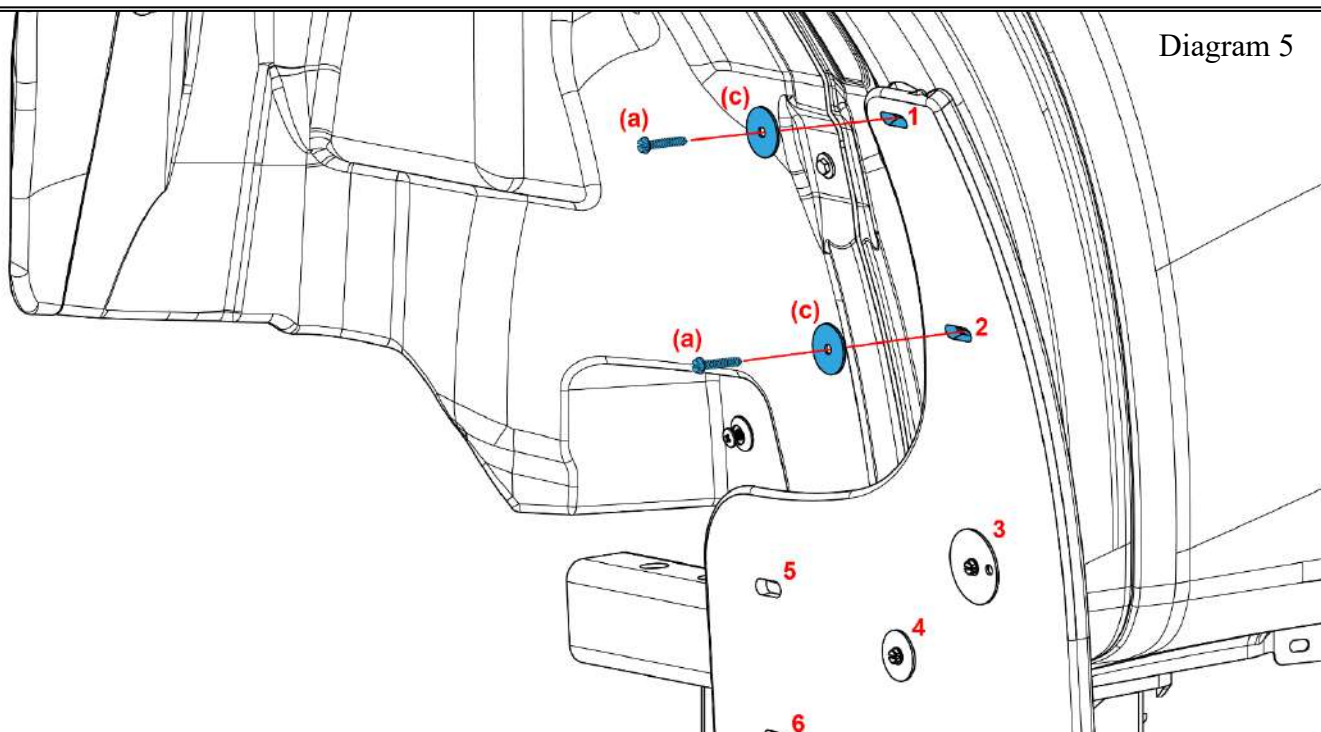

5: Loosely install hardware as shown

Diagram 6

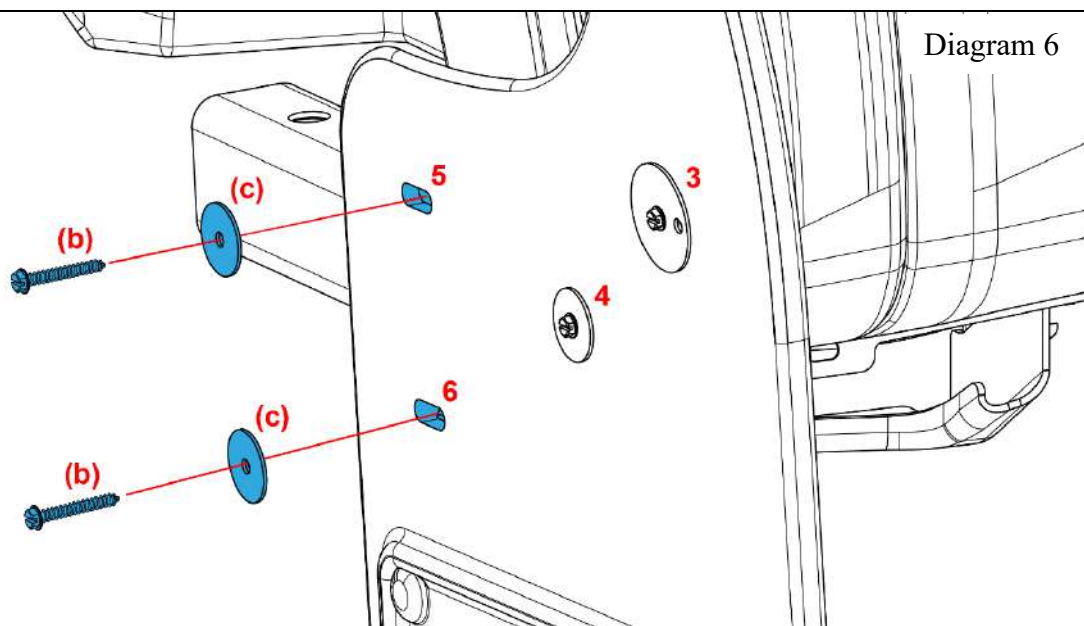

6: Loosely install hardware through holes #5 & #6 into the impact bar bracket. Hole #6 should be installed first.

Diagram 7

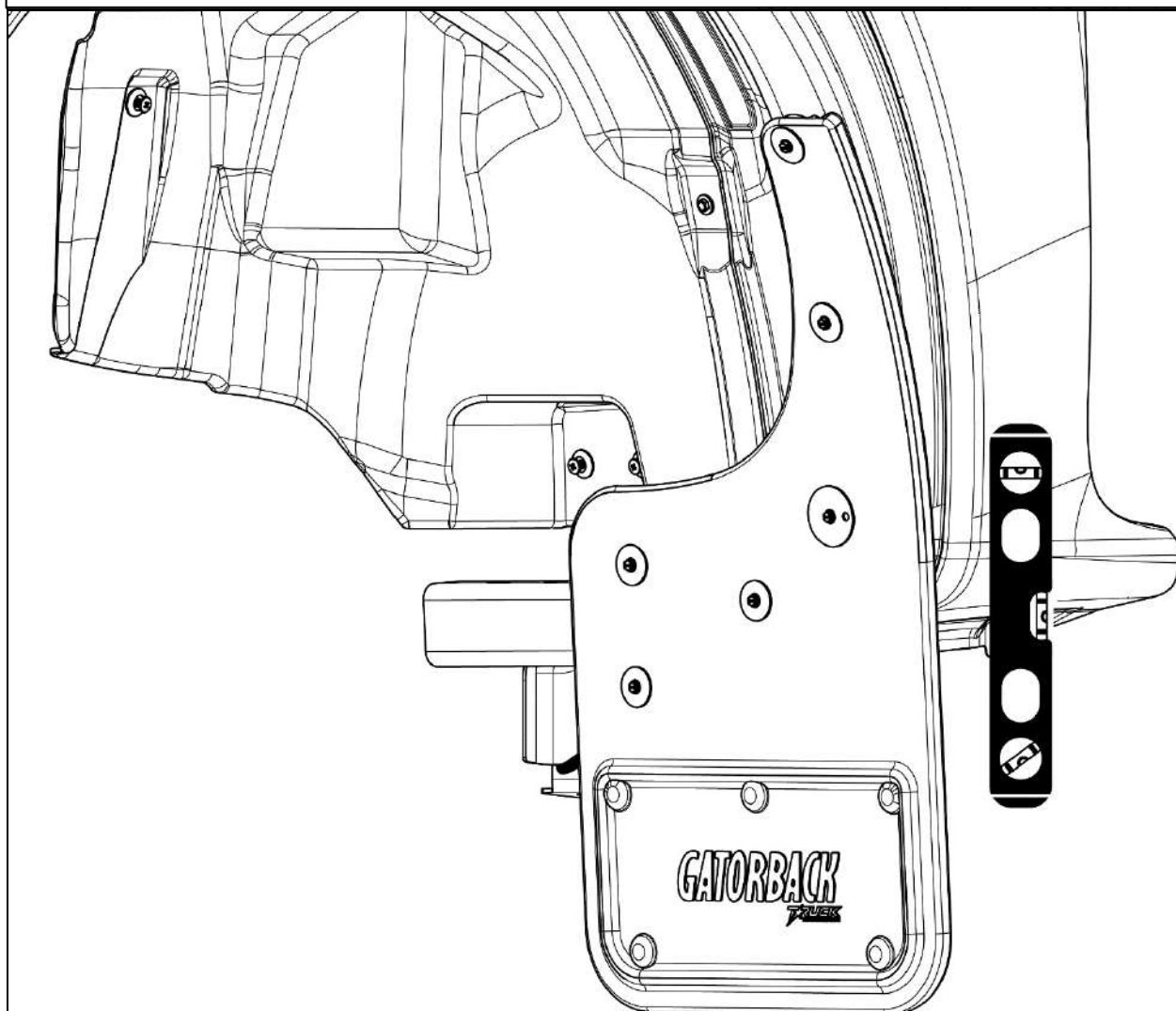

7: Use a levelling tool to sure flap is level and tighten all fasteners.

IMPORTANT:

The manufacturer is not responsible for negligent use of vehicle with mud flaps installed, including over-tightening of screws and bolts causing damage to vehicle or mud flaps.

TOOLS REQUIRED:

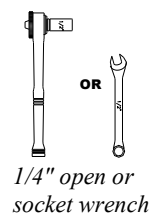
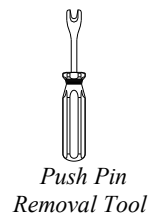
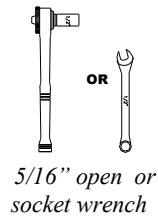
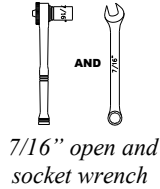
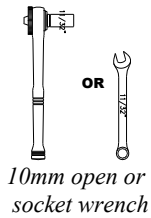

FLAPS AND BRACKETS

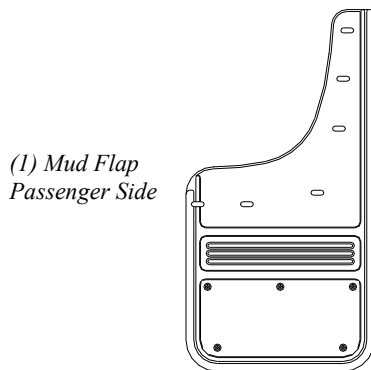
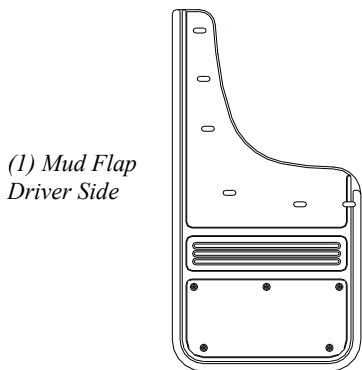

PARTS BAG #770895

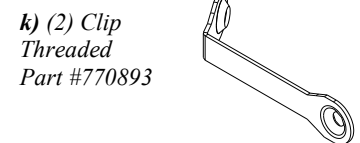
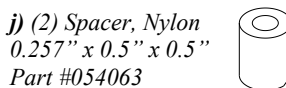
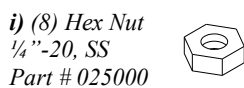
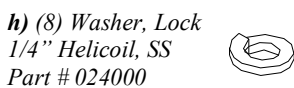
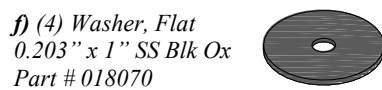
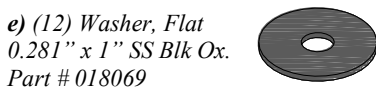
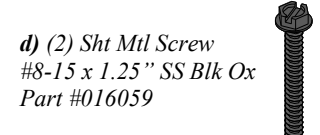
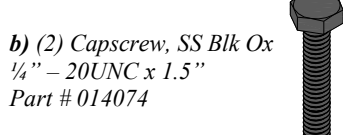
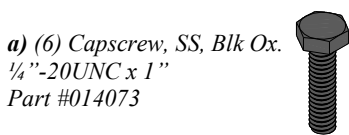

Installation

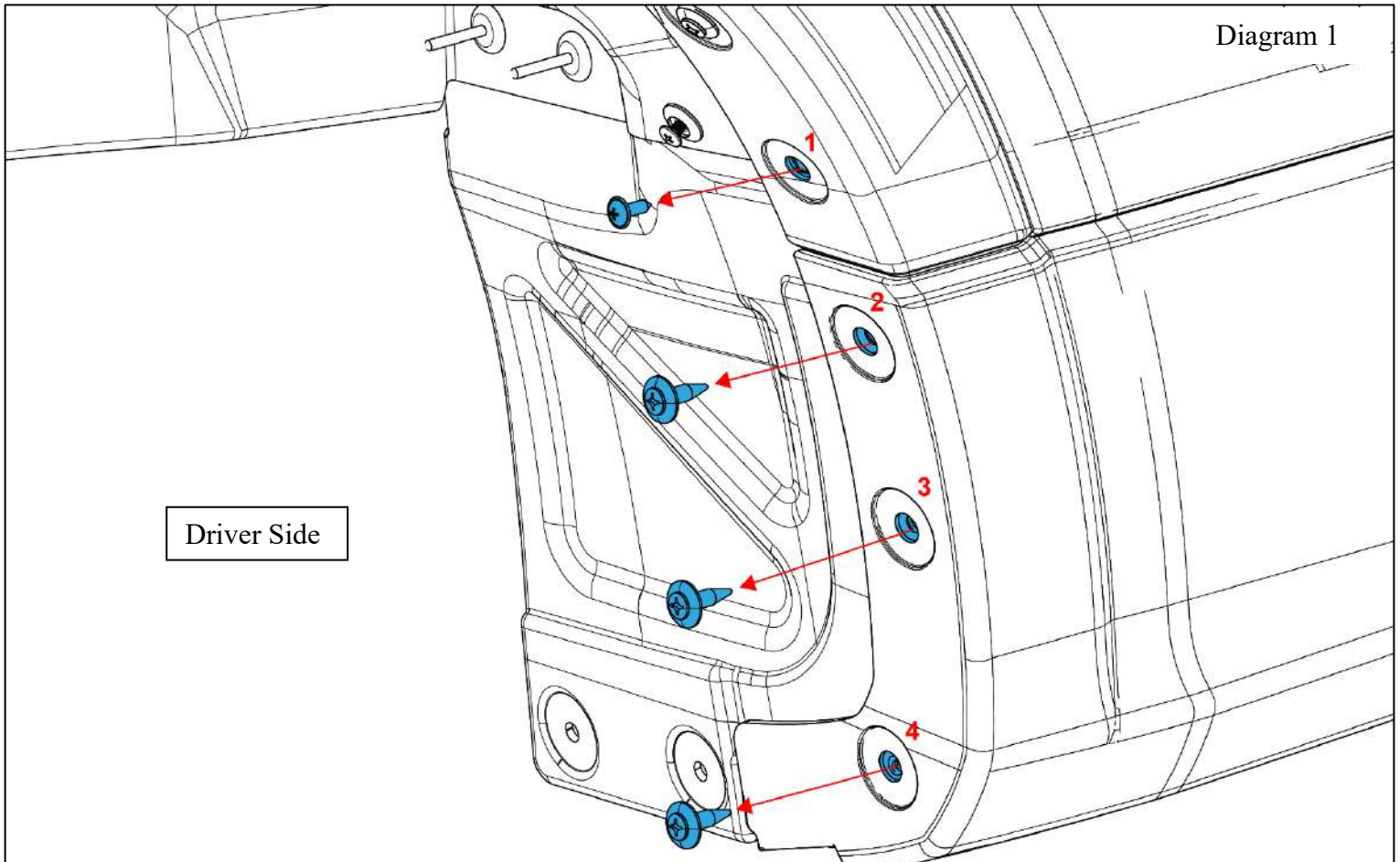

1: Remove the factory hardware on the fender as shown. Discard.

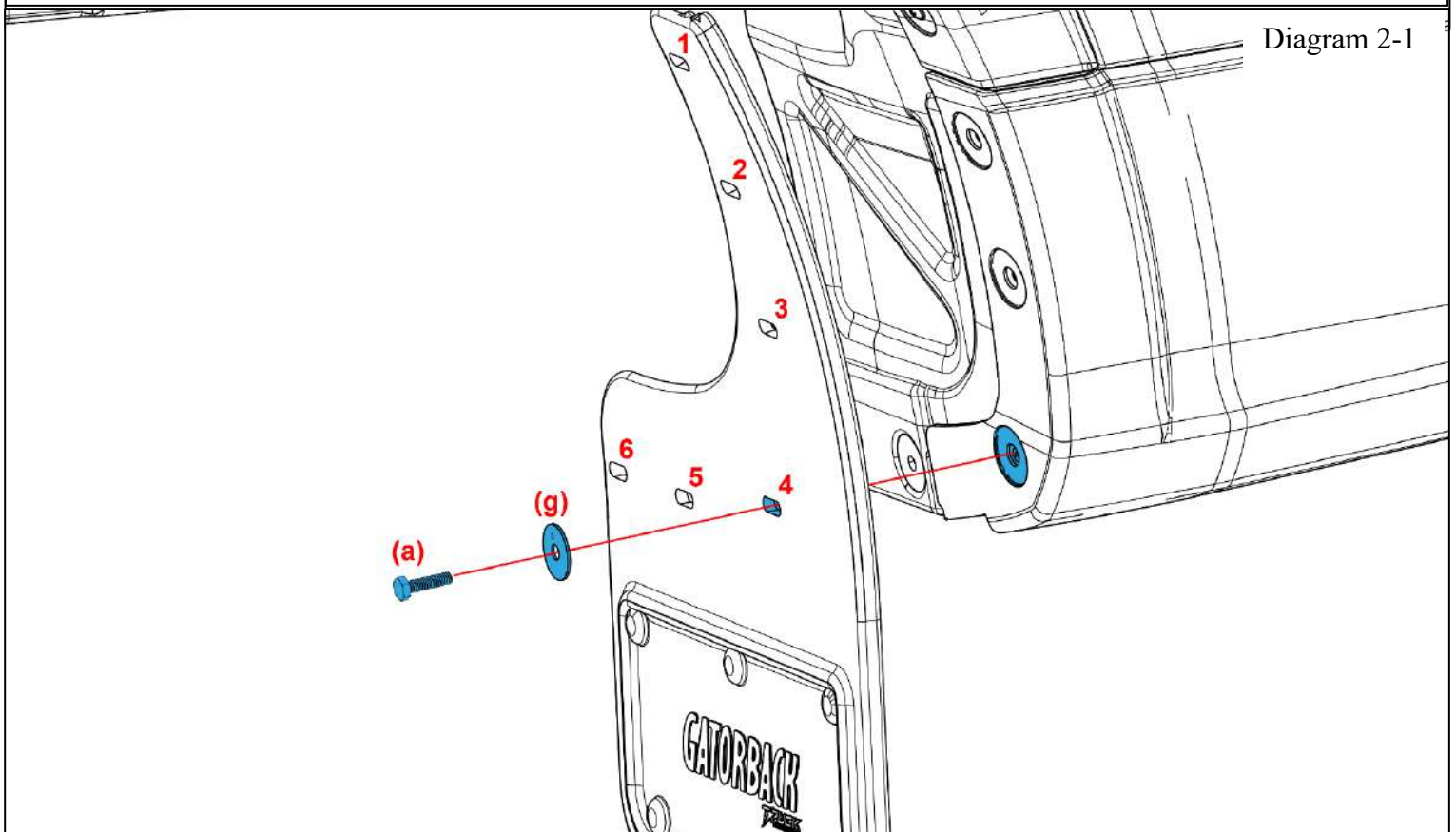

2-1: Loosely install hardware as shown.

Diagram 2-2

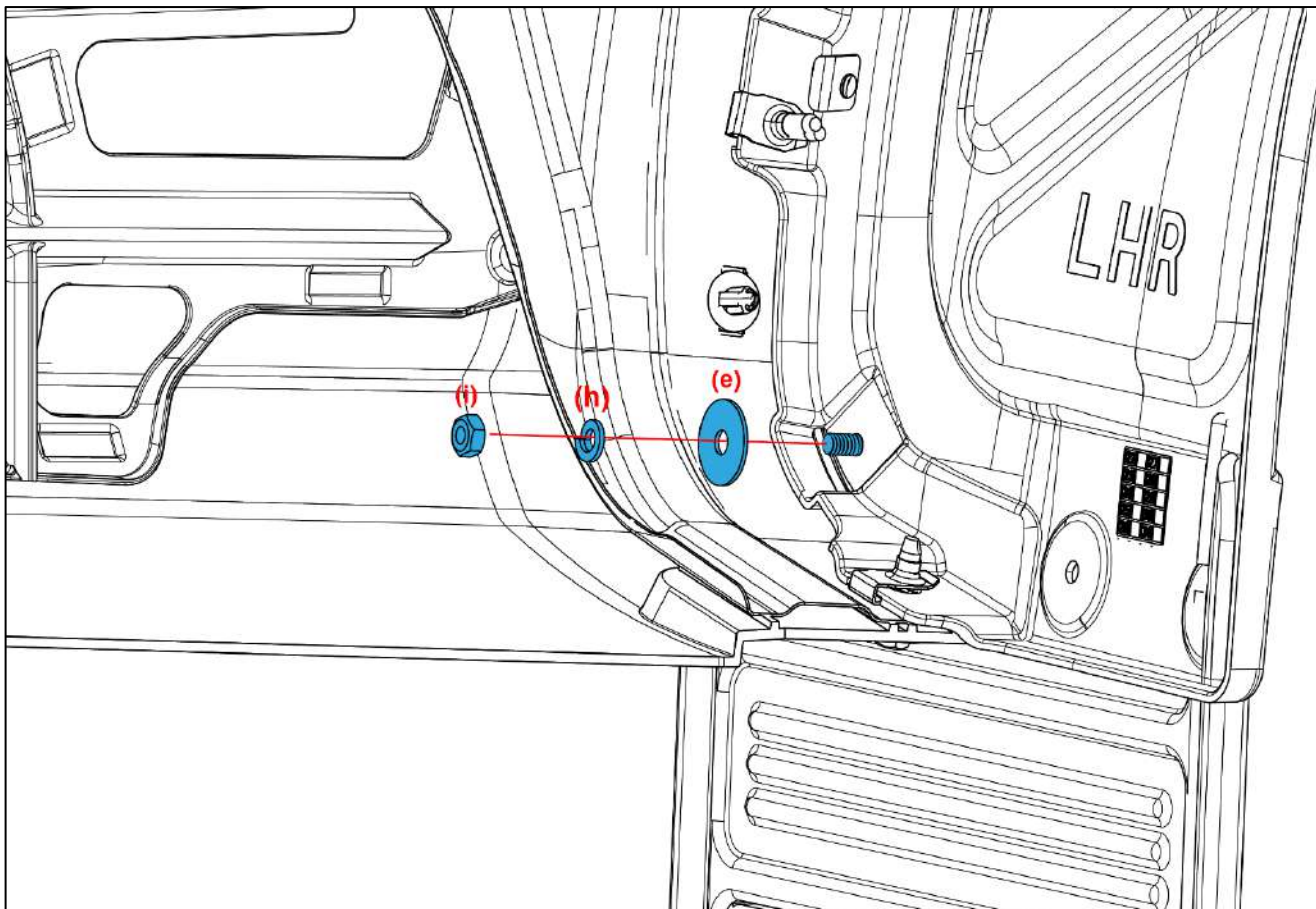

2-2: Secure hardware installed in step 2-1 as shown.

Diagram 3-1

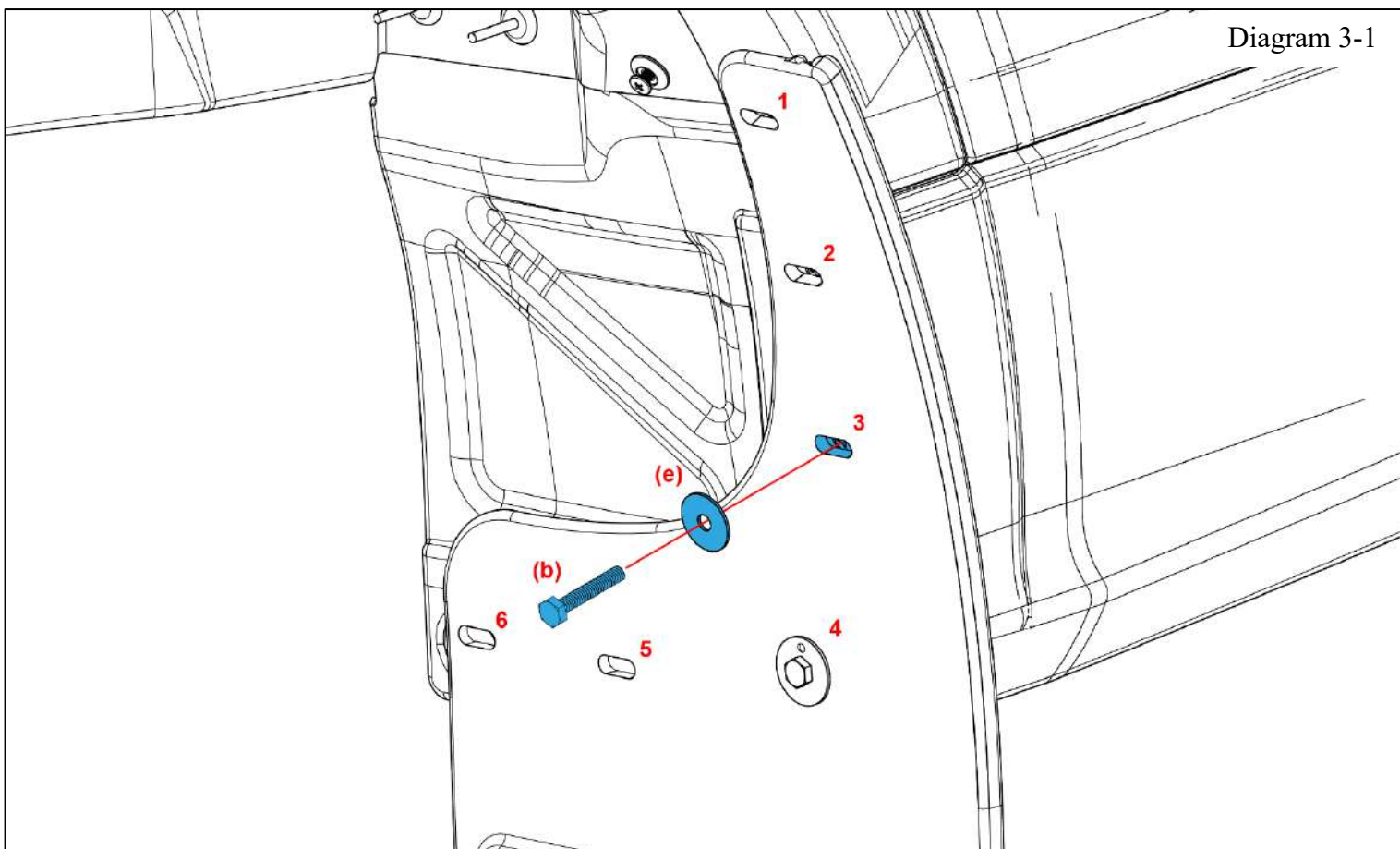

3-1: Loosely install hardware as shown.

Diagram 3-2

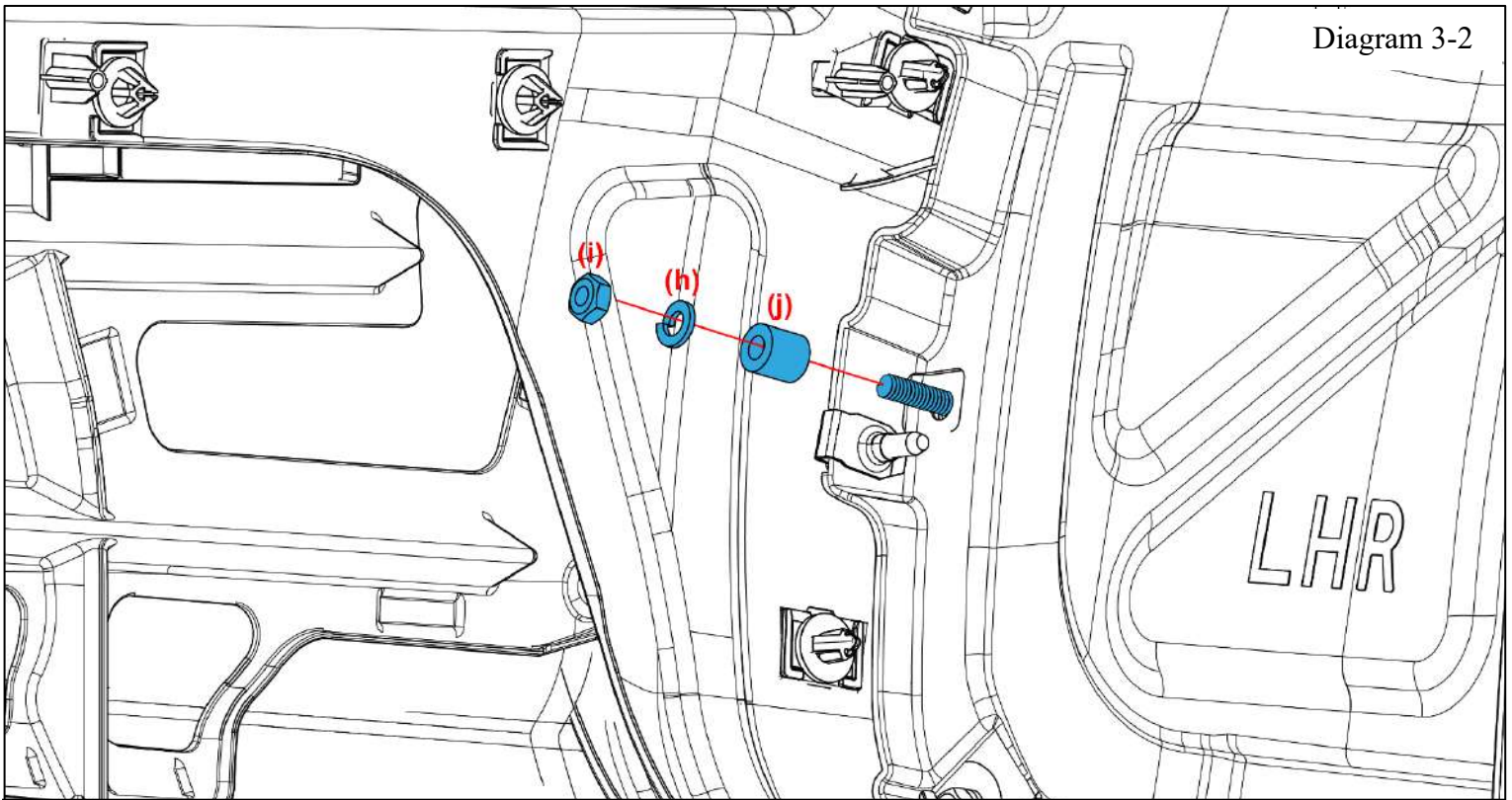

3-2: Secure hardware installed in step 3-1 as shown.

Diagram 4-1

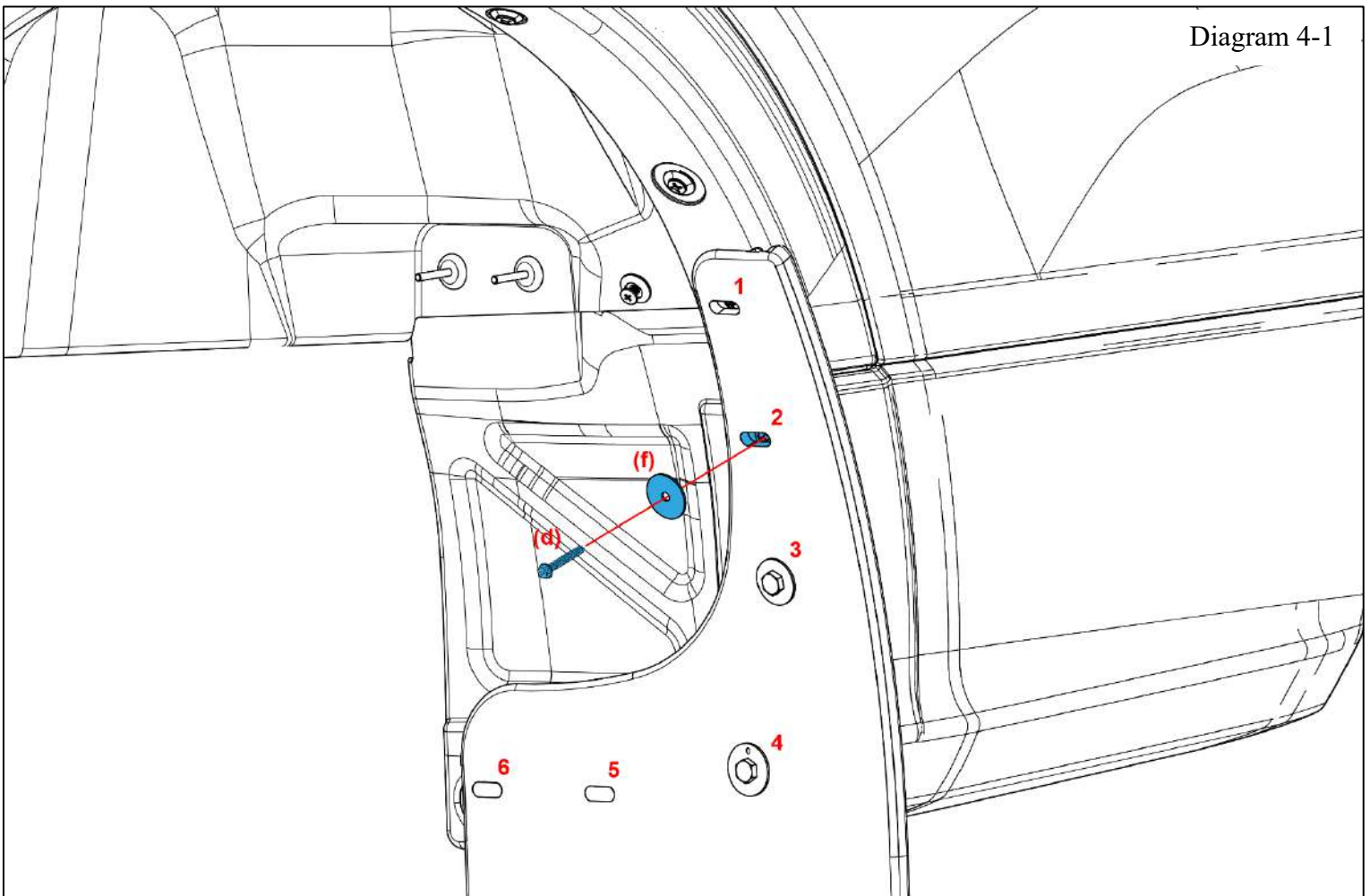

4-1: While holding the threaded clip from behind, install hardware through hole #2 and into clip as shown in Step 4-2

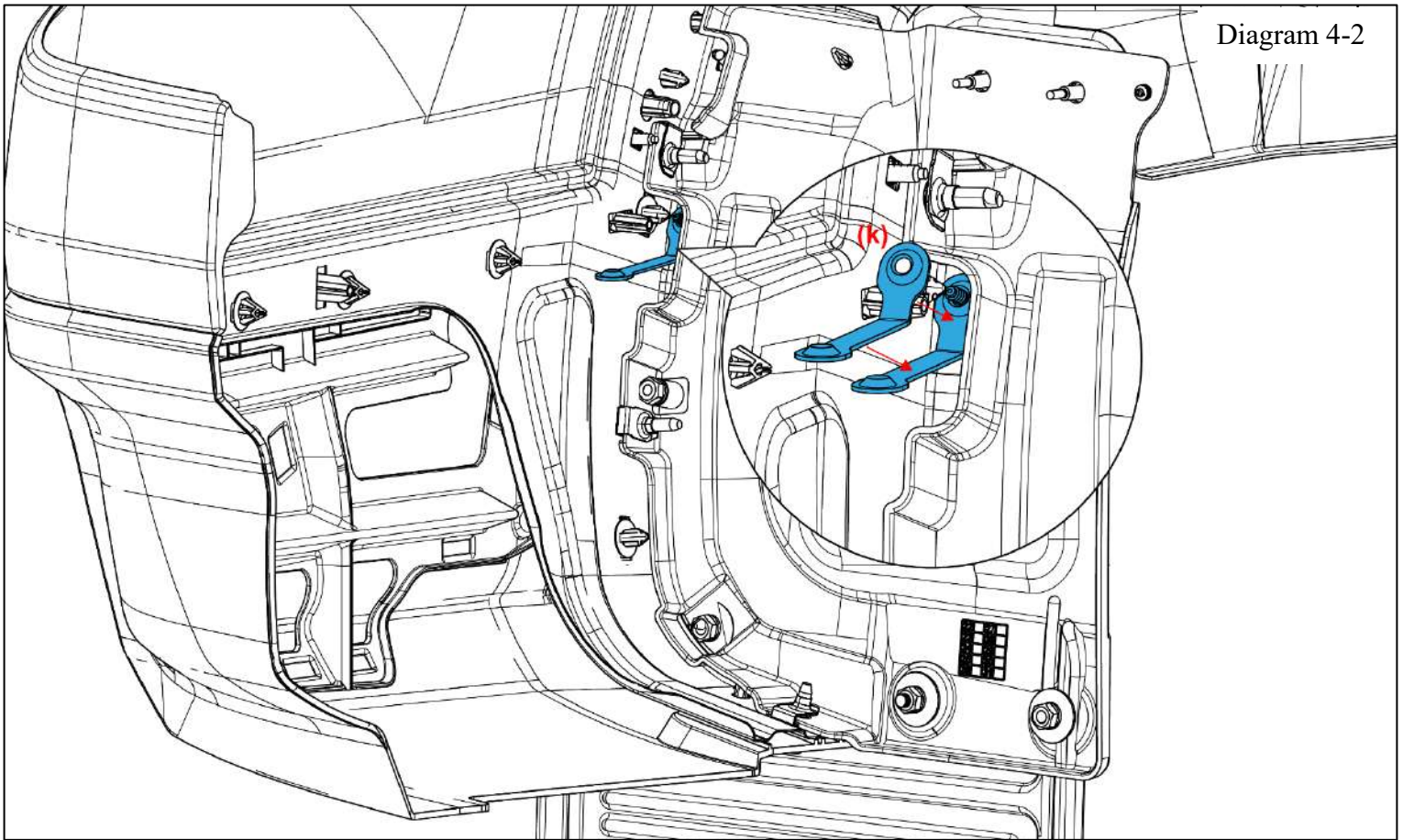

Diagram 4-2

4-2: Loosely install hardware from step 4-1 into the threaded clip as shown.

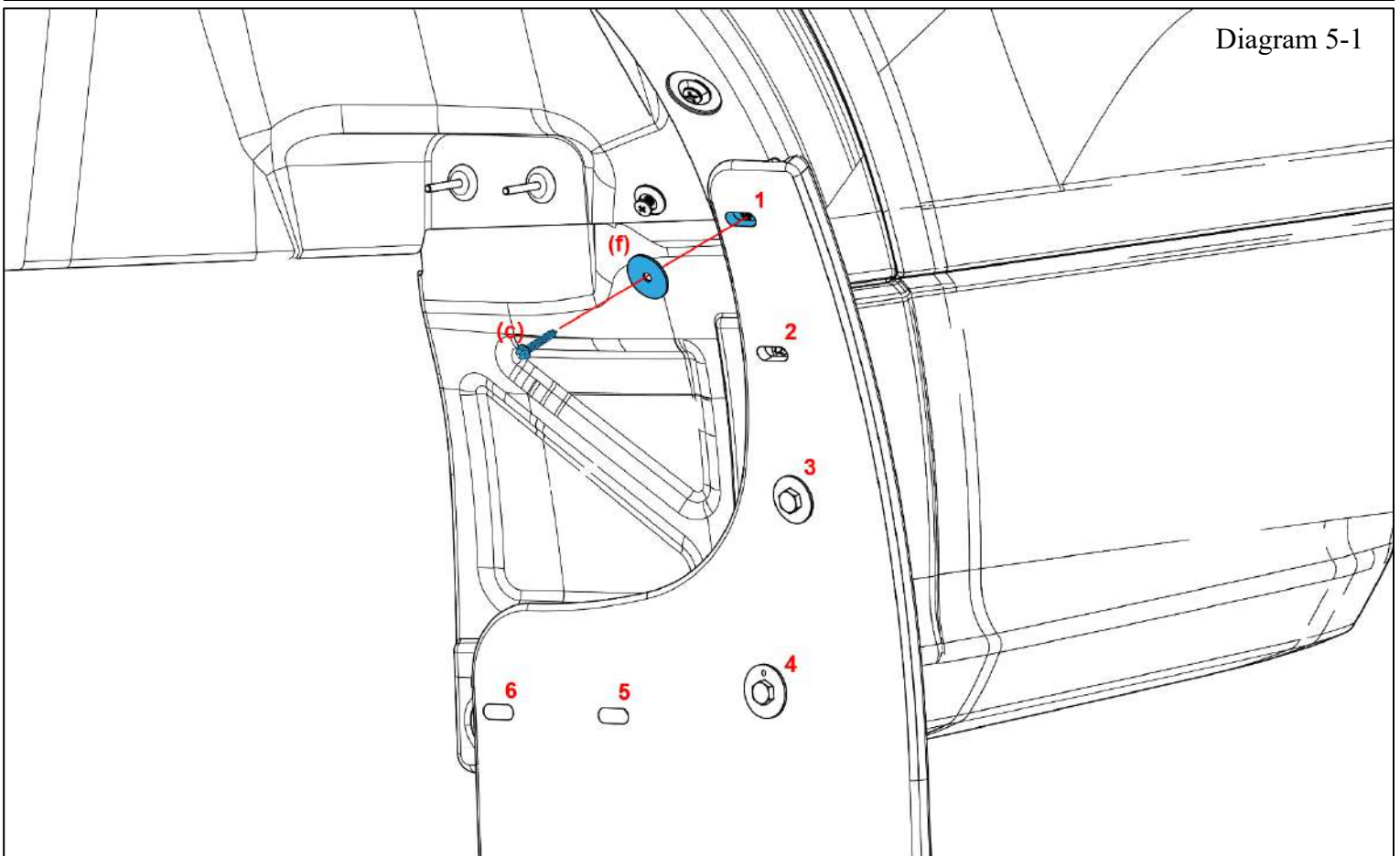
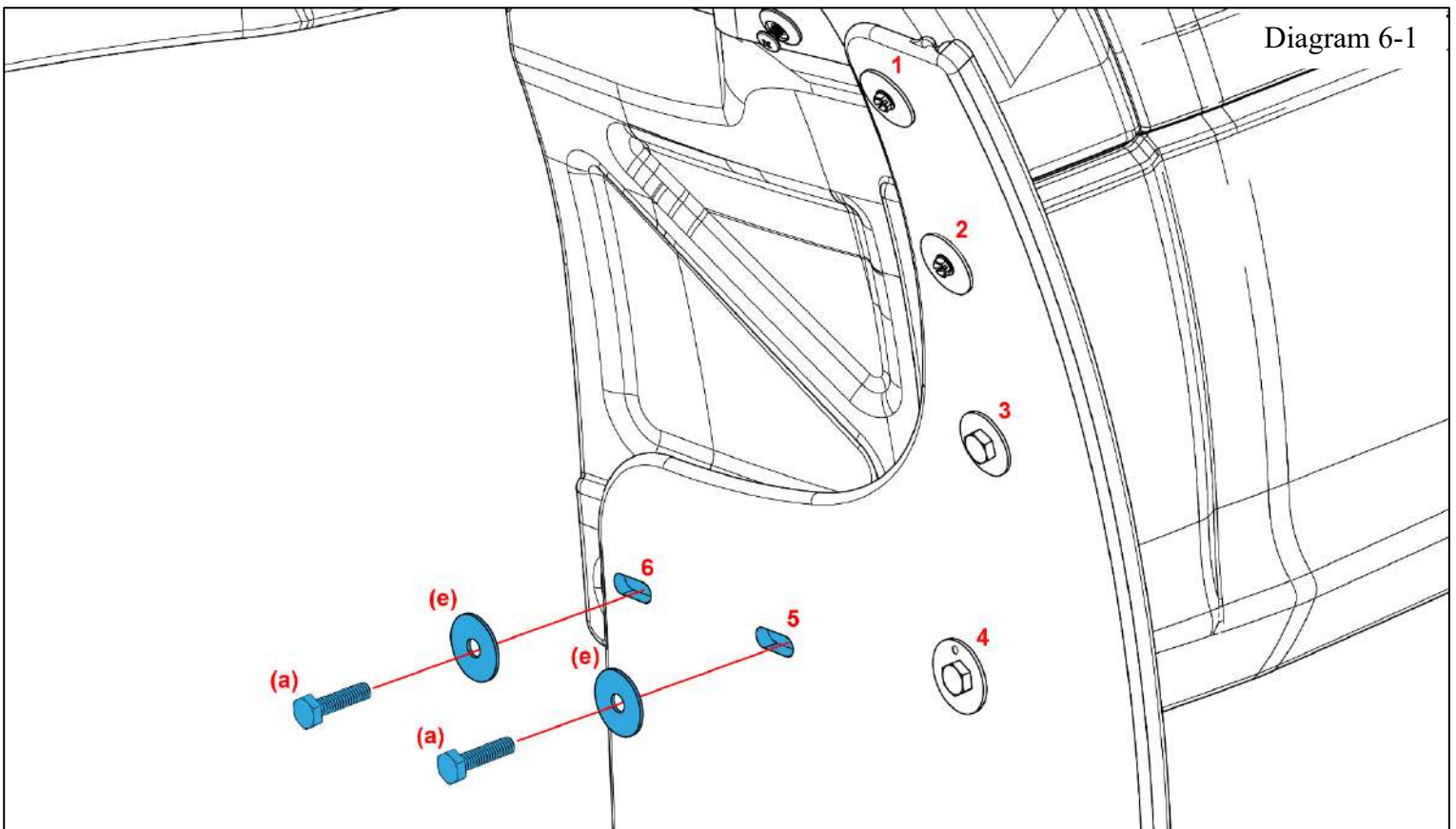

Diagram 5-1

5-1: Loosely install hardware as shown.

Diagram 6-1



6-1: Loosely install hardware as shown and secure from behind with hardware shown in Step 6-2

Diagram 6-2

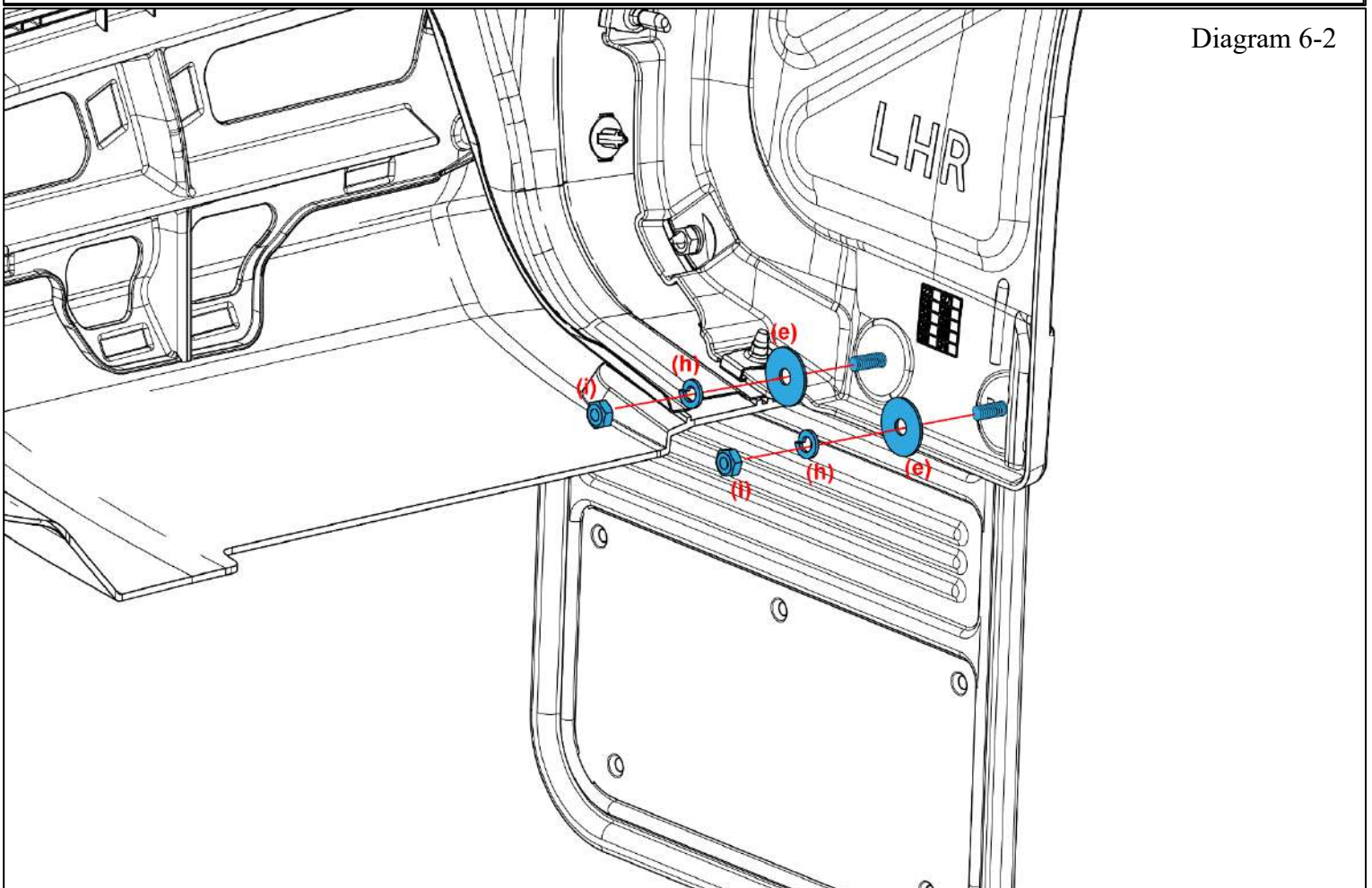

6-2: Secure hardware installed in step 6-1 as shown.

Diagram 7-1

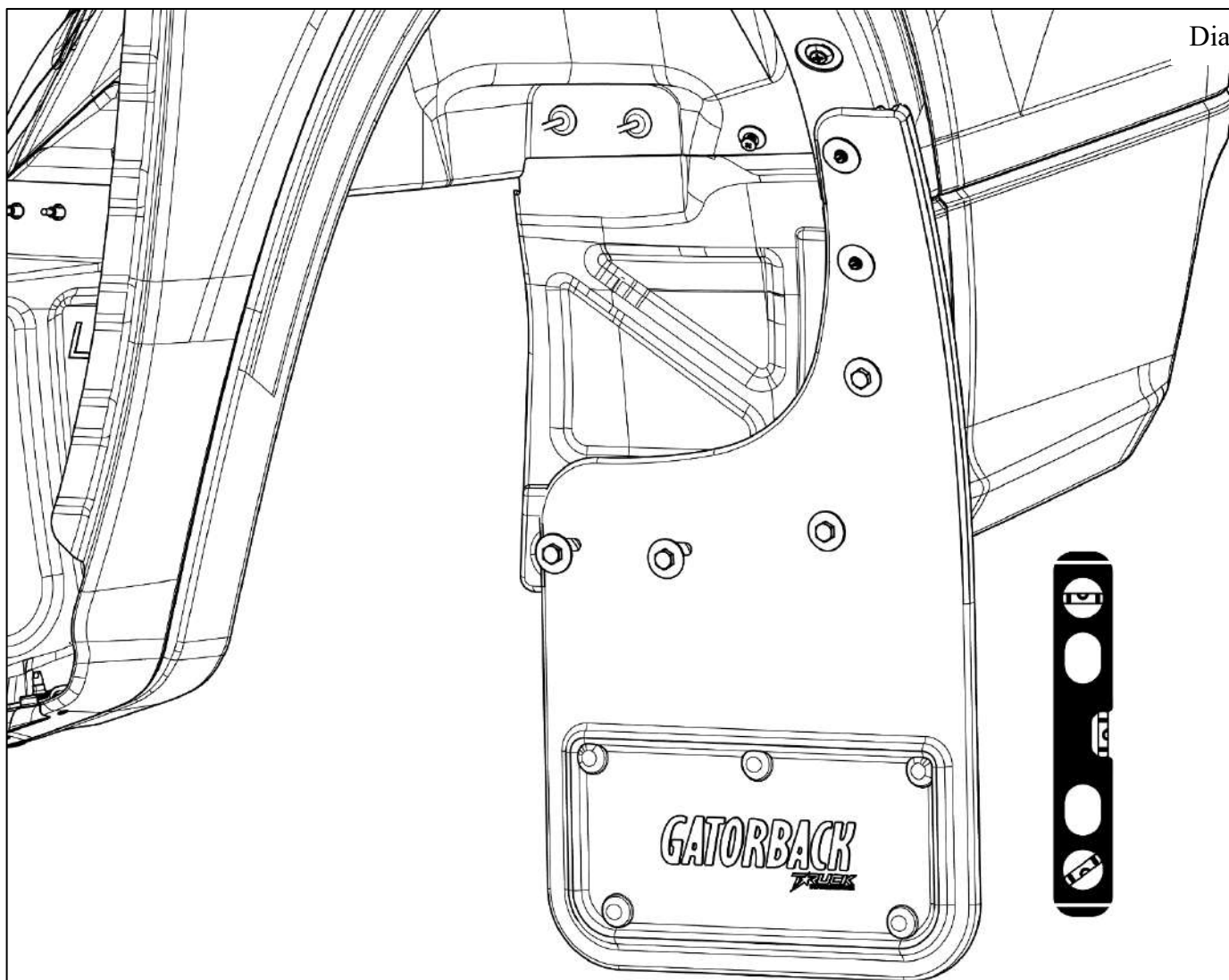

7: Use a levelling tool to ensure flap is level and tighten all fasteners.