

## REAR INSTALLATION *(For ease of installation it is suggested that the wheel be removed)*

1. Remove the 5 factory screws from the existing factory guard. Set this hardware aside for later reinstallation.
2. Gently pull the guard from the truck.
3. Position cap, ensuring the top lip of the cap slides under the fender molding as shown.
4. If installing Gatorback Mud Flaps, reinstall the two factory screws on the underside and back of the finishing cap. If no flaps are being installed, reinstall the five factory screws to secure the cap. Be careful not to overtighten.
5. Repeat procedure on passenger side.

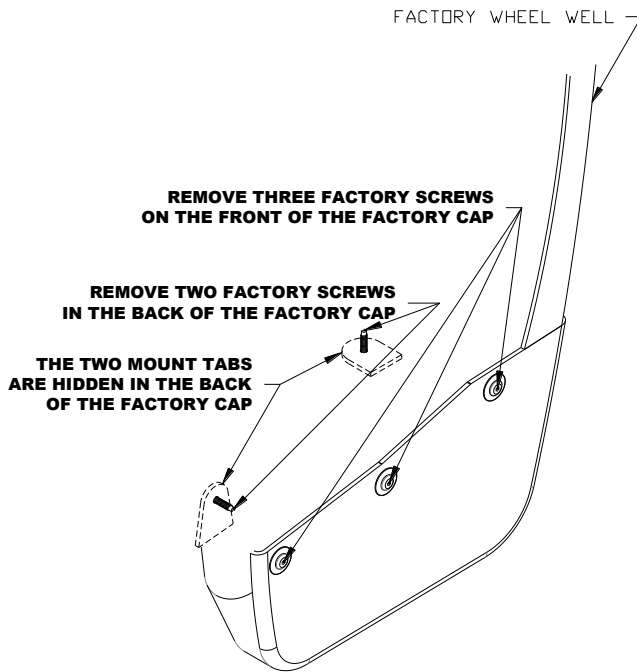

FACTORY CAP (GUARD) DRIVER SIDE SHOWN

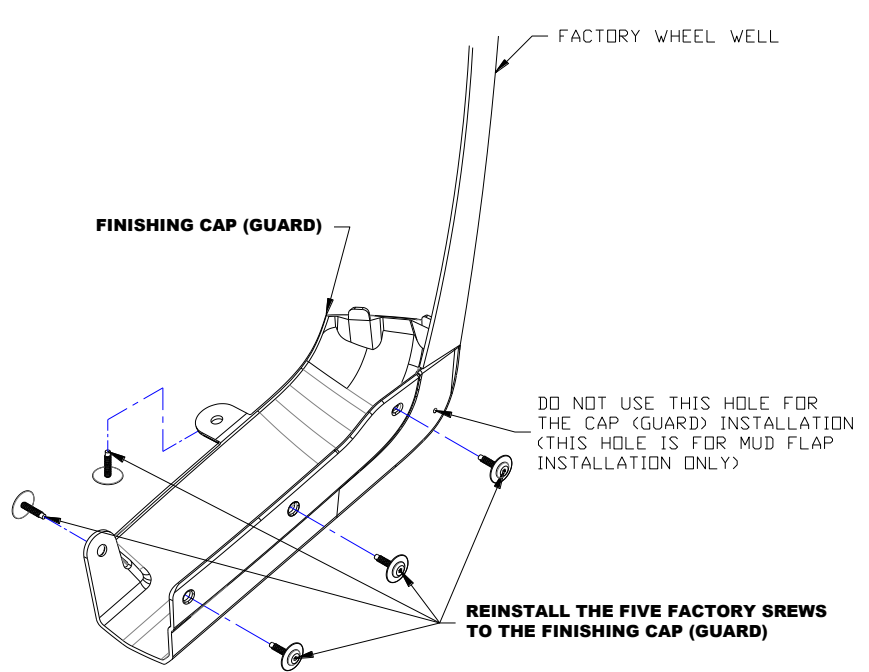

FINISHING CAP (GUARD) DRIVER SIDE SHOWN

## FRONT INSTALLATION *(For ease of installation it is suggested that the wheel be removed)*

1. Remove the 5 factory screws from the existing factory guard. Set this hardware aside for later reinstallation.
2. Gently pull the flare molding away from the body of the truck, and then quickly pull the guard down and away from the body of the truck to release the clip on the inside of the factory guard.
3. Slightly peel back the red 3M tape on the finishing cap and fold back so it can be fully peeled after cap is in place.
4. Position cap, ensuring the top lip of the cap slides under the fender molding as shown.
5. If installing Gatorback Mud Flaps, reinstall the two factory screws on the underside and back of the finishing cap. If no flaps are being installed, reinstall the five factory screws to secure the cap. Be careful not to overtighten.
6. Finish peeling 3M tape and press firmly on the bottom and side of the finishing cap to ensure a proper seal.
7. Repeat procedure on passenger side.

